

RB

Belt-Over Roller Conveyor

The model RB is designed to move heavier loads. Roller bed design reduces belt friction and provides greater capacity. Applications include: assembly, inspection, and packing operations.

- Reversible
- Moves Heavier Loads
- Center Drive
- System Ends
- Pop-out Roller
- Adjustable MS-Type Floor Supports Available

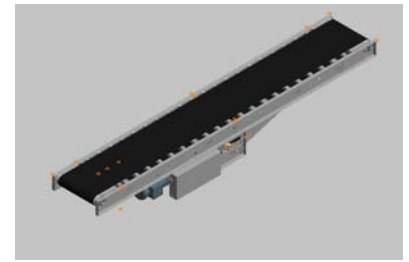

Conveyor shown in Standard Gray.

Size to Order Overall Length "A" 4" Dia. Tail Pulley	Bed Length "L"	Bet- ween Rail Width	Between Rail Width		Size to Order OAL "A" 6" Dia. Pulley	Between Rail Width		
			15"	21"		27"	33"	39"
		Belt Width	12"	18"	24"	30"	36"	42"
		Overall Frame Width	18"	24"	30"	36"	42"	
12'	10'	Weights	593	689	12'	791	940	1088
17'	15'	(lbs.)	696	804	17'	919	1085	1250
22'	20'		800	920	22'	1047	1230	1412
27'	25'		903	1035	27'	1175	1375	1574
32'	30'		1007	1150	32'	1304	1520	1735
37'	35'		1110	1266	37'	1432	1665	1897
42'	40'		1213	1381	42'	1560	1810	2059
47'	45'		1317	1496	47'	1688	1955	2221
52'	50'		1420	1612	52'	1816	2100	2383
57'	55'		1524	1727	57'	1944	2245	2545
62'	60'		1627	1842	62'	2072	2390	2707
67'	65'		1731	1957	67'	2200	2535	2869
72'	70'		1834	2073	72'	2328	2680	3031
77'	75'		1938	2188	77'	2456	2825	3193
82'	80'		2041	2303	82'	2585	2970	3354
87'	85'		2145	2419	87'	2713	3115	3516
92'	90'		2248	2534	92'	2841	3260	3678
97'	95'		2352	2649	97'	2669	3405	3840
102'	100'		2455	2765	102'	3097	3550	4002

All weights in catalog are conveyor weights only. Accessories, crating, etc., are not included.



Standard Specifications

BELT – Ultimate 140 BBS–Nitrile.

BED – Roller bed with 1.9 in. dia. roller x 16 ga. galvanized tube spaced every 6 in. Mounted in 6 1/2 in. x 12 ga. powder-painted formed steel channel frame bolted together with splice plates.

CROSS BRACING – Rods with turnbuckles are fastened to underside of bed to provide proper alignment of bed rollers and ensure correct product tracking. Supplied to section adjoining drive and every other section, 20 ft. bed lengths and over. Supplied on bed lengths 9 ft. and over.

CENTER DRIVE – Minimum elevation is 17 3/4 in. Can be placed on any section of conveyor length. Minimum OAL without modification is 120 in. Chain guard located on left hand side.

DRIVE PULLEY – 8 in. dia. with 1 7/16 in. dia. shaft at bearings, fully lagged.

TAIL PULLEY – 4 in. dia. with 1 in. dia. shaft at bearings or 6 in. dia. with 1 3/16 in. dia. shaft at bearings; machine crowned.

SNUB IDLER – Adjustable 2 1/8 in. dia. pre-lubricated ball bearings. Guards included.

RETURN IDLER – Adjustable 1.9 in. dia. pre-lubricated ball bearings.

TAKE-UP – Take-ups in center drive provides 16 in. of belt take-up.

BEARINGS – Sealed, pre-lubricated, self-aligning, ball bearings on drive and tail pulleys. Pre-lubricated ball bearings in tread rollers.

SPEED REDUCTION – Sealed worm gear C-face speed reducer. No. 50 roller chain to drive pulley.

MOTOR – 1/2 HP, 208/230/460/575V, 3 Ph. 60 Hz. Totally enclosed C-face.

BELT SPEED – Constant 65 FPM.

CAPACITY – Maximum load per linear foot of conveyor 225 lbs. NOT TO EXCEED capacity in charts.

FLOOR SUPPORTS – Supplied as optional equipment.

Live Load Capacity-40° Incline @ 65 FPM			
HP	Belt Widths To	Lengths Up To	
		52'	102'
Distributed Load (lbs.)			
1/2	14"	2490	2150
	24"	2280	1800
	36"	1860	1170
1	14"	5500	5160
	24"	5290	4810
	36"	4870	4180
2	14"	11520	11170
	24"	11320	10830
	36"	10890	10200

RB

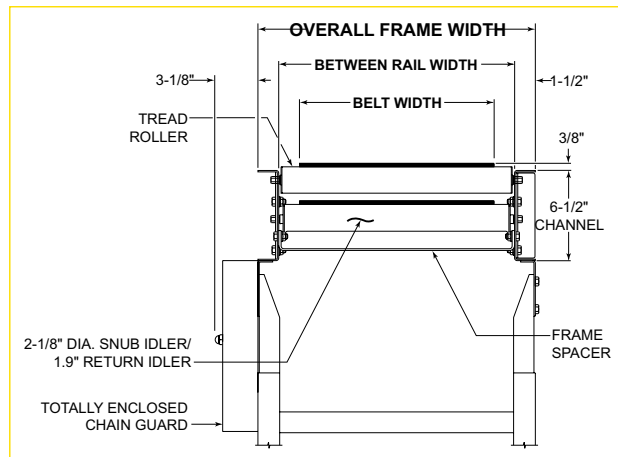
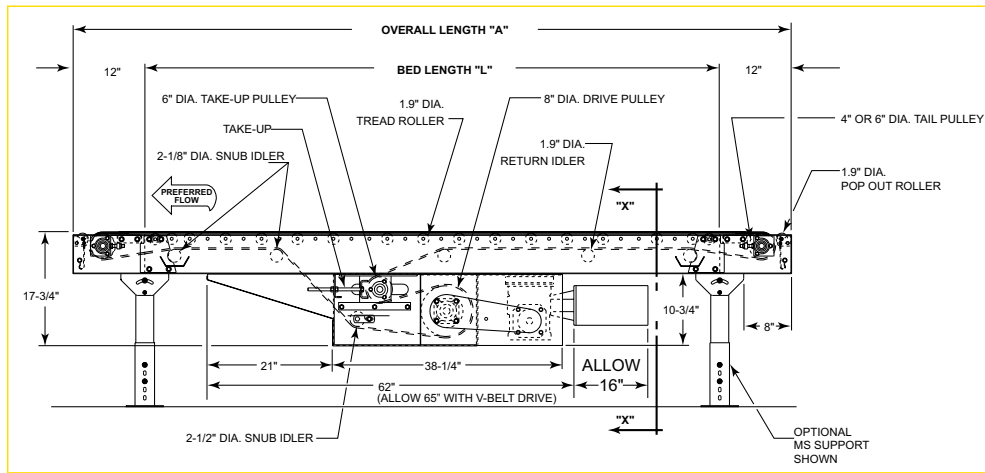

SECTION "X-X"

Optional Equipment

FLOOR SUPPORTS – MS Type floor supports are available with a wide range of adjustment. Specify top of belt or roller elevation. One support required at every bed joint and ends of conveyor. Holes in feet for lagging to floor. Knee braces recommended above MS-6 support.

BELT* – Black Trackmate 120 Highgrip Longitudinal Groove, White Polymate 100 RMP-COS (cover one side), Black Trackmate 533 COS-PVC, Tan Glidetop.

BELT SPEED* – Other constant and variable speeds. V-belt drive supplied on speeds under 17 FPM.

END DRIVE – 8 in. end drive mounted on end of unit. Requires underside take-up.

LOW ELEVATION SIDE MOUNTED CENTER DRIVE – Motor reducer unit mounted to side of conveyor. Minimum 16 in.

V-BELT DRIVE – V-belt supplied between motor and reducer. Allow 65 in.

O-RING DRIVE CHAIN – With sealed-in lubricant (recommended for applications that do not permit regular lubrication).

UNDERSIDE TAKE-UP – Provides 16 in. of belt take-up. Extends down 15 7/8 in. from top of belt.

GUARD RAILS – Adjustable Universal Channel Guard Rail, fixed channel, type A and B angle. Fixed Channel overlapping, one direction. Fixed Channel nonoverlapping, reversing. See Accessory section.

ROLLER CENTERS* – Tread rollers spaced on 3 in., 9 in., or 12 in. centers.

PULLEYS – 6 in. dia. tail with 1 3/16 in. dia. shaft at bearings in place of 4 in. when not furnished as standard.

POLY-TIER SUPPORTS – 36 in. to 120 in. support heights in 6 in. increments. Knee braces supplied.

CEILING HANGER – 5/8 in. dia. x 8 ft. long unplated rods fully threaded. Other lengths and galvanized rods available.

MOTOR – Energy efficient, single phase, brake motor, other characteristics. 2 HP maximum.

ELECTRICAL CONTROLS – Non-reversing or reversible magnetic starter, and push-button stations. AC variable frequency drive.

* Note: Capacity affected with these options.