

# TL

## Heavy Duty Horizontal Belt Conveyor

The Model TL with its rugged, heavy duty construction is ideally used for long assembly line operations, inspections, testing, sorting, and packing. Can be floor supported or ceiling hung.

- 6 Belt Widths
- Reversible (with center drive)
- Rugged Construction
- Adjustable MS-Type Floor Supports Available



Conveyor shown with optional floor supports

SIZE TO ORDER Overall Length "A" 6" Dia. Tail Pulley	Bed Length "L"	Overall Length with Center Drive	Belt Width	24"	30"	36"	42"	48"	52"
			Bed Width	30"	36"	42"	48"*	54"*	58"*
7'-1"	5'	6'-4"	WEIGHTS (Lbs.)	375	N/A	N/A	N/A	N/A	N/A
12'-1"	10'	11'-4"		475	555	615	888	974	1060
17'-1"	15'	16'-4"		625	686	752	1084	1191	1298
22'-1"	20'	21'-4"		725	796	867	1280	1408	1536
27'-1"	25'	26'-4"		875	967	1065	1476	1625	1774
32'-1"	30'	31'-4"		975	1077	1180	1672	1842	2012
37'-1"	35'	36'-4"		1125	1248	1377	1868	2059	2250
42'-1"	40'	41'-4"		1225	1358	1492	2064	2276	2488
47'-1"	45'	46'-4"		1375	1529	1690	2260	2493	2726
52'-1"	50'	51'-4"		1475	1639	1805	2456	2710	2964
57'-1"	55'	56'-4"		1625	1810	2002	2652	2927	3202
62'-1"	60'	61'-4"		1725	1920	2117	2848	3144	3440
67'-1"	65'	66'-4"		1875	2091	2315	3044	3361	3678
72'-1"	70'	71'-4"		1975	2201	2430	3240	3578	3916
77'-1"	75'	76'-4"		2125	2372	2627	3436	3795	4154
82'-1"	80'	81'-4"		2225	2482	2742	3632	4012	4392
87'-1"	85'	86'-4"		2375	2653	2940	3828	4229	4630
92'-1"	90'	91'-4"		2479	2763	3055	4024	4446	4868
97'-1"	95'	96'-4"		2625	2934	3252	4220	4663	5106
102'-1"	100'	101'-4"		2725	3044	3367	4416	4880	5334

- NOTE:**
- All weights in catalog are CONVEYOR WEIGHTS ONLY. Accessories, crating, etc., are not included.
  - \*5'-0" Bed, V-Belt Drive Only
  - 36" Bed Width - 1 Week Stockyard .

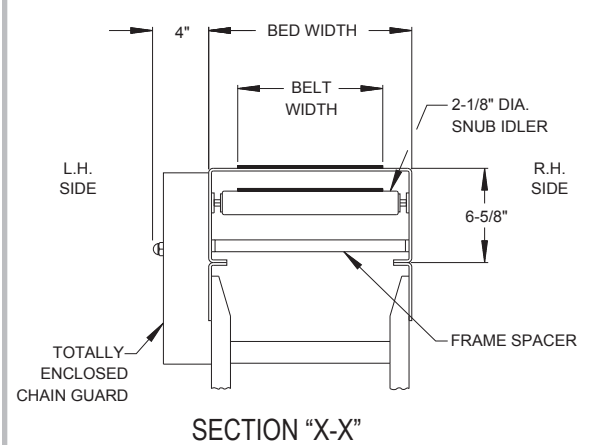
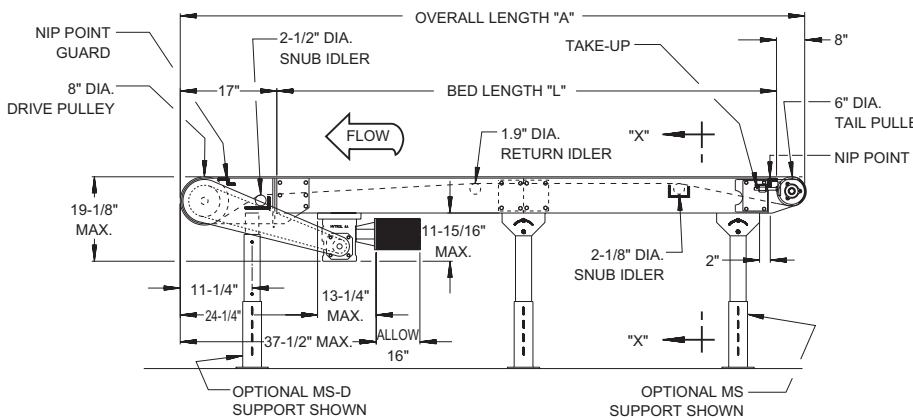

# • STANDARD SPECIFICATIONS

**BELT**—Ultimate 140 BBS—Nitrile.

**BED**—6 3/8 in. deep x 12 ga. formed steel slider bed powder painted. Reinforced with 3/4 in. pipe which forms sockets for guard rails. Standard 5 ft. & 10 ft. long sections bolt together with splice plates. 48 in. and 51 in. bed widths are available in 5 ft. lengths only.

**END DRIVE**—Located on discharge end of conveyor, chain guard on left hand side.

**DRIVE PULLEY**—8 in. dia. with 1 3/8 in. dia. shaft at bearings, machine crowned and fully lagged.

**TAIL PULLEY**—6 in. dia. with 1 3/8 in. dia. shaft at bearings, machine crowned.

**SNUB IDLER**—Adjustable 2 1/8 in. dia. for tail end 2 1/2 in. dia. for drive end. Pre-lubricated ball bearings. Guards included.

**RETURN IDLER**—Adjustable 1.9 in. dia. pre-lubricated ball bearings.

**TAKE-UP**—Take-ups at tail pulley. Provides 4 in. of belt take-up.

**BEARINGS**—Sealed, pre-lubricated, self-aligning, ball bearings on drive and tail pulleys.

**SPEED REDUCTION**—Sealed worm gear C-Face speed reducer. No. 50 roller chain to drive pulley.

**MOTOR—1 HP**—208/230/460/575V—3 Ph.—60 Hz. Premium Energy Efficient C-Face.

**BELT SPEED**—Constant 65 FPM.

**CAPACITY**—Maximum load per linear foot of conveyor 100 lbs. NOT TO EXCEED capacity in charts.

**FLOOR SUPPORTS**—Now supplied as optional equipment.

8" DIA. DRIVE PULLEY HORIZONTAL LIVE LOAD CAPACITY @ 65 FPM			
HP	BELT WIDTHS TO	LENGTHS UP TO	
		52'	102'
		DISTRIBUTED LOAD (LBS.)	
1	24" - 30"	530	350
	36" - 42"	450	250
	48" - 52"	360	100
2	24" - 30"	1250	1100
	36" - 42"	1200	950
	48" - 52"	1100	850

# • OPTIONAL EQUIPMENT

**FLOOR SUPPORTS**—MS Type floor supports are available with a wide range of adjustment. Specify top of belt or roller elevation. One support required at every bed joint and ends of conveyor. Holes in feet for lagging to floor. Knee braces recommended above MS-6 support.

**BELT\***—White Polymate 100 RMP-COS (cover one side), Black Trackmate 120 Roughtop with PVC cover, Brown Polymate Roughtop w/Nitrile cover, Black Trackmate 533 COS-PVC, Tan Glidetop, Pure Gum Rubber Roughtop. Incline units: Black Trackmate 120 High Grip Longitudinal Groove.

**BELT SPEED\***—Other constant and variable speeds. V-belt drive supplied on speeds under 17 FPM.

**OVERHEAD END DRIVE**—Motor-reducer unit mounted 9 1/2 in. above belt. Other clearances available, specify. (Chain guard right hand side). Minimum elevation—10 in.

**SIDE MOUNTED END DRIVE**—Motor-reducer unit mounted left hand side of conveyor. Minimum elevation 10 in.

**CENTER DRIVE**—Provides 16 in. of belt take-up. Minimum elevation 20 in. Specify location. Minimum OAL 66 in.

**LOW ELEVATION SIDE MOUNTED CENTER DRIVE**—Motor-reducer unit mounted to side of conveyor. Minimum elevation 16 1/2 in.

**STACKED END DRIVE**—Contact factory for minimum elevations.

**V-BELT DRIVE**—V-Belt supplied between motor and reducer. Minimum overall drive width 14 in. Allow 65 in.

**O-RING DRIVE CHAIN**—With sealed in lubricant (Recommended for applications that do not permit regular lubrication).

**UNDERSIDE TAKE-UP**—Provides 16 in. of belt take-up. Extends down 15 3/4 in. from top of belt.

**NOSEOVER\***—Adjustable, single (0 ° to 15 °), double (0 ° to 30 °).

**LOWER POWERED FEEDER\***—Chain type driven from tail pulley of inclined conveyor. Underside take-up required when end drive is used. MS-Type floor supports now supplied as optional equipment. 8 in. dia. drive recommended on conveyor when feeder exceeds 44 1/2 in. OAL—50 1/2 in. OAL with system end.

**BUTT COUPLINGS**—Provides connection to SB, RB, LR, ACC, ACZ, ABEZ, 190-NSP, 190-NSPEZ, 20-CR, 1.9 in. & 2.0 in. gravity conveyors. Includes 1 in. dia. pop out roller. Center drive or underside take-up recommended.

**SYSTEM END ROLLER**—12 in. long tail sections provide connection to: SB, RB, LR, ACC, ACZ, ABEZ, 190 NSP, 190-NSPEZ, 1.9 in. & 2.0 in. gravity conveyors. Includes 1.9 in. dia. pop-out transfer roller. Belt width is 6 in. less than bed width. Center drive or underside take-up required.

**GUARD RAILS**—Adjustable Universal Channel Guard Rail, solid side guards, PC side guards with formed top.. Fixed Channel overlapping, one direction (use with systems ends only). Fixed Channel non-overlapping, reversing (use with system ends only).

**CASTERS**—See Accessory section.

**POLY-TIER SUPPORTS**—36 in. to 120 in. support heights in 6 in. increments. Knee braces supplied.

**CEILING HANGERS**—3/8 in. dia. x 8 ft. long unplated rods fully threaded. Other lengths and galvanized rods available.

**MOTORS**—Single phase, brakemotor, other characteristics. 2 HP maximum.

**ELECTRICAL CONTROLS**—One direction manual start switch, reverse drum switch, non-reversing and reversible magnetic starters, push button stations. AC variable frequency drive.

**\*NOTE:** Capacity affected with these options.

