

GSRCT

Gravity Roller Curve with 1.9OD x 16 GA. Rollers with True Tapered Plastic Sleeves.

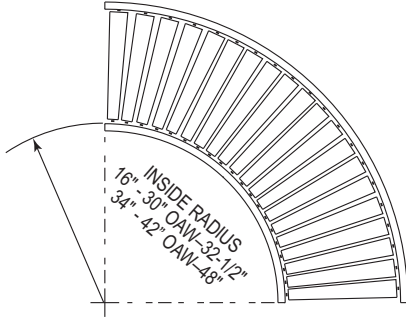

Conveyor shown in green.
 Standard color options:



OAW	BR	Inside Radius	Rollers Per Curve 30°	Model No. 19GSRCT Galvanized	Weight (lbs.) 30°

OAW	BR	Inside Radius	Rollers Per Curve 45°	Model No. 19GSRCT Galvanized	Weight (lbs.) 45°
16"	13"	32 1/2"	10	19GSRCT-13-45	51
18"	15"		10	19GSRCT-15-45	55
20"	17"		10	19GSRCT-17-45	62
22"	19"		10	19GSRCT-19-45	68
24"	21"		10	19GSRCT-21-45	71
26"	23"		10	19GSRCT-23-45	76
28"	25"		10	19GSRCT-25-45	81
30"	27"	48"	10	19GSRCT-27-45	86
34"	31"		16	19GSRCT-31-45	148
36"	33"		16	19GSRCT-33-45	156
40"	37"		16	19GSRCT-37-45	172
42"	39"		16	19GSRCT-39-45	181

OAW	BR	Inside Radius	Rollers Per Curve 60°	Model No. 19GSRCT Galvanized	Weight (lbs.) 60°
16"	13"	32 1/2"	14	19GSRCT-13-60	69
18"	15"		14	19GSRCT-15-60	75
20"	17"		14	19GSRCT-17-60	79
22"	19"		14	19GSRCT-19-60	89
24"	21"		14	19GSRCT-21-60	97
26"	23"		14	19GSRCT-23-60	101
28"	25"		14	19GSRCT-25-60	111
30"	27"	48"	14	19GSRCT-27-60	115
34"	31"		21	19GSRCT-31-60	203
36"	33"		21	19GSRCT-33-60	210
40"	37"		21	19GSRCT-37-60	230
42"	39"		21	19GSRCT-39-60	236

OAW	BR	Inside Radius	Rollers Per Curve 90°	Model No. 19GSRCT Galvanized	Weight (lbs.) 90°
16"	13"	32 1/2"	20	19GSRCT-13-90	103
18"	15"		20	19GSRCT-15-90	112
20"	17"		20	19GSRCT-17-90	119
22"	19"		20	19GSRCT-19-90	133
24"	21"		20	19GSRCT-21-90	145
26"	23"		20	19GSRCT-23-90	152
28"	25"		20	19GSRCT-25-90	167
30"	27"	48"	20	19GSRCT-27-90	173
34"	31"		32	19GSRCT-31-90	305
36"	33"		32	19GSRCT-33-90	315
40"	37"		32	19GSRCT-37-90	345
42"	39"		32	19GSRCT-39-90	355

GSRCT

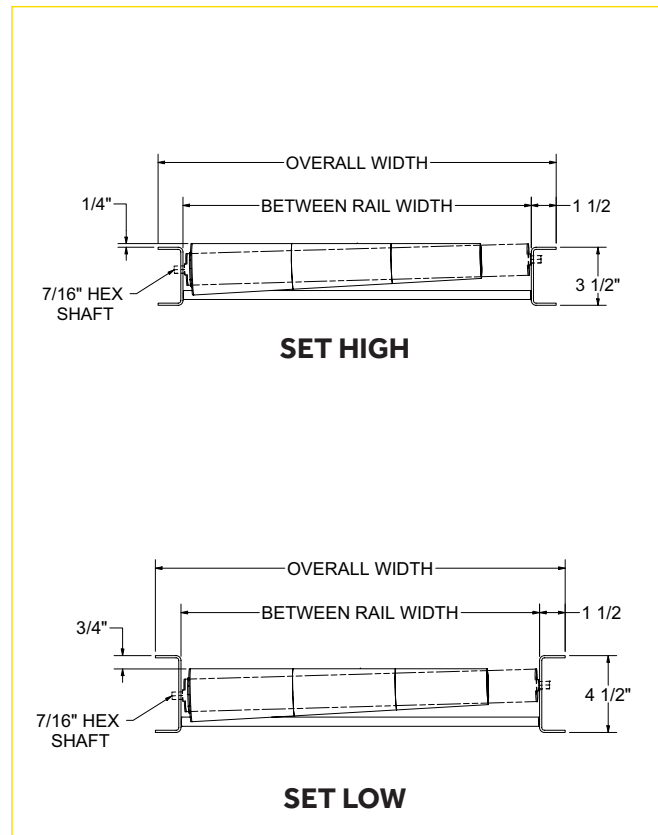

Standard Specifications

WIDTHS – Between rail width: 13 in., 15 in., 17 in., 19 in., 21 in., 23 in., 25 in., 27 in., 31 in., 33 in., 37 in., and 39 in.

FRAME – 3 1/2 in. or 4 1/2 in. deep x 1 1/2 in. flange x 10 ga. powder-painted formed steel channel with bolt-in cross members.

BUTT COUPLINGS – Bolt-on type for bolting sections together.

CURVES – 30, 45, 60, and 90 degree. 32 1/2 in. inside radius for widths up to 27 in. and 48 in. inside radius for 31 in. to 39 in. between rail width.

ROLLERS – 19-GSRCT 2 1/2 in. dia. tapered to 1 11/16 in. dia. x 14 ga. galvanized steel tubing. Bearings are grease packed.

AXLES – 7/16 in. hex shaft; spring loaded.

CAPACITY – Same per foot capacity as straight sections. See charts on previous page.