

19GSRC

Heavy-Duty Gravity Roller Curve Conveyor

Gravity Roller Curve Conveyor with either 1.9 in. dia. x 16 ga. rollers.

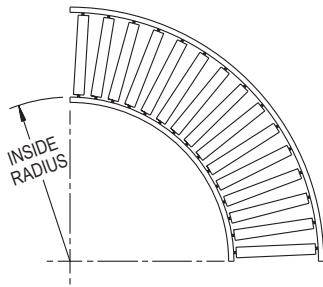

OAW	BR	Inside Radius	Rollers Per Curve 45°	Model No. 19GSRC Galvanized	Weight (lbs.) 45°
16"	13"	32 1/2"	11	19GSRC-13-45S	50
18"	15"		11	19GSRC-15-45S	53
20"	17"		11	19GSRC-17-45S	58
22"	19"		11	19GSRC-19-45S	63
24"	21"		11	19GSRC-21-45S	67
26"	23"		22	19GSRC-23-45D	82
28"	25"		22	19GSRC-25-45D	85
30"	27"	48"	22	19GSRC-27-45D	89
34"	31"		22	19GSRC-31-45D	108
36"	33"		22	19GSRC-33-45D	112
40"	37"		22	19GSRC-37-45D	120
42"	39"		22	19GSRC-39-45D	124

OAW	BR	Inside Radius	Rollers Per Curve 30°	Model No. 19GSRC Galvanized	Weight (lbs.) 30°
16"	13"	32 1/2"	7	19GSRC-13-30S	32
18"	15"		7	19GSRC-15-30S	35
20"	17"		7	19GSRC-17-30S	38
22"	19"		7	19GSRC-19-30S	40
24"	21"		7	19GSRC-21-30S	43
26"	23"		12	19GSRC-23-30D	53
28"	25"		12	19GSRC-25-30D	56
30"	27"	48"	12	19GSRC-27-30D	58
34"	31"		18	19GSRC-31-30D	70
36"	33"		18	19GSRC-33-30D	73
40"	37"		18	19GSRC-37-30D	79
42"	39"		18	19GSRC-39-30D	82

OAW	BR	Inside Radius	Rollers Per Curve 60°	Model No. 19GSRC Galvanized	Weight (Lbs) 60°
16"	13"	32 1/2"	14	19GSRC-13-60S	65
18"	15"		14	19GSRC-15-60S	70
20"	17"		14	19GSRC-17-60S	76
22"	19"		14	19GSRC-19-60S	81
24"	21"		14	19GSRC-21-60S	87
26"	23"		32	19GSRC-23-60D	107
28"	25"		32	19GSRC-25-60D	113
30"	27"	48"	32	19GSRC-27-60D	118
34"	31"		32	19GSRC-31-60D	141
36"	33"		32	19GSRC-33-60D	147
40"	37"		32	19GSRC-37-60D	159
42"	39"		32	19GSRC-39-60D	165

OAW	BR	Inside Radius	Rollers Per Curve 90°	Model No. 19GSRC Galvanized	Weight (lbs.) 90°
16"	13"	32 1/2"	22	19GSRC-13-90S	97
18"	15"		22	19GSRC-15-90S	105
20"	17"		22	19GSRC-17-90S	114
22"	19"		22	19GSRC-19-90S	122
24"	21"		22	19GSRC-21-90S	131
26"	23"		42	19GSRC-23-90D	161
28"	25"		42	19GSRC-25-90D	169
30"	27"	48"	42	19GSRC-27-90D	177
34"	31"		42	19GSRC-31-90D	211
36"	33"		42	19GSRC-33-90D	220
40"	37"		42	19GSRC-37-90D	238
42"	39"		42	19GSRC-39-90D	247

19GSRC

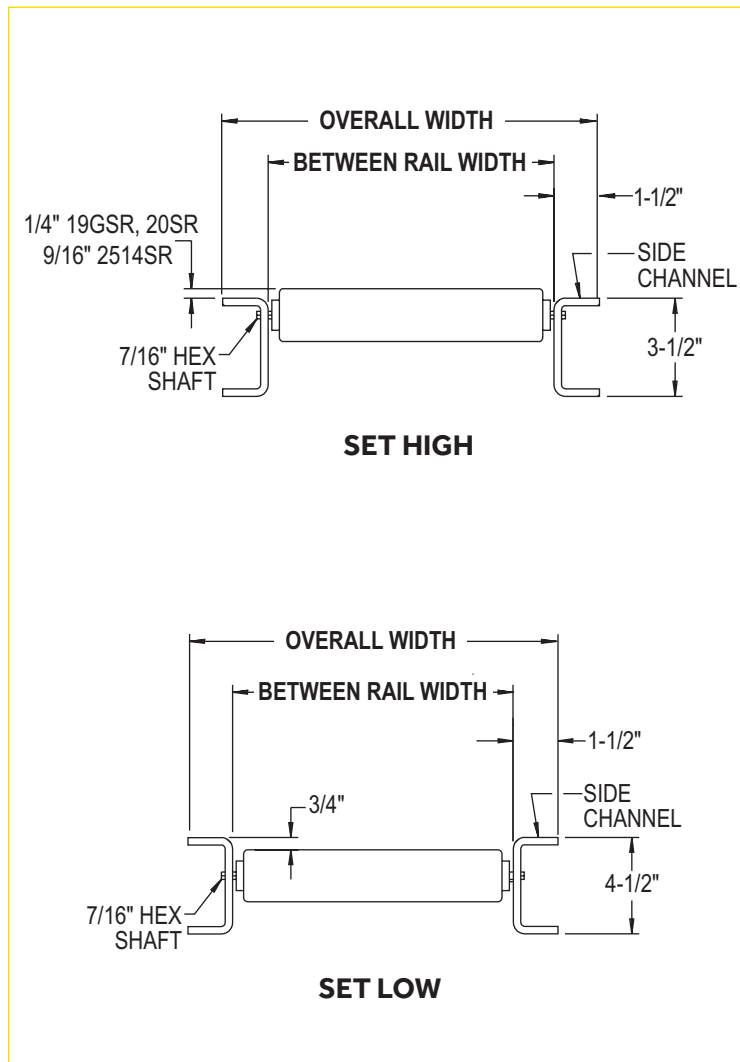

Standard Specifications

WIDTHS – Between rail width: 13 in., 15 in., 17 in., 19 in., 21 in., 23 in., 25 in., 27 in., 31 in., 33 in., 37 in., and 39 in.

FRAME – 3 1/2 in. or 4 1/2 in. deep x 1 1/2 in. flange x 10 ga. powder-painted formed steel channel with bolt-in cross members.

BUTT COUPLINGS – Bolt-on type for bolting sections together.

CURVES – 30, 45, 60, and 90 degree. 32 1/2 in. inside radius for widths up to 27 in. and 48 in. inside radius for 31 in. to 39 in. between rail width.

ROLLERS – 19GSRC 1.9 in. dia. x 16 ga. galvanized steel tubing. Bearings are labyrinth sealed and grease packed.

AXLES – 7/16 in. hex shaft; spring loaded.

CAPACITY – Same per foot capacity as straight sections. See charts on previous page.