

# 190-E24

## 24 VDC Live Roller

The model 190-E24 24 VDC Live Roller Conveyor uses a series of 24 VDC motors to drive the tread rollers, eliminating the need for drive belts, chains, or line shafts.

Quiet operation and ease of maintenance and installation are just some of the advantages.

- All-Electric Operation
- Adjustable MS-Type Floor Supports Available

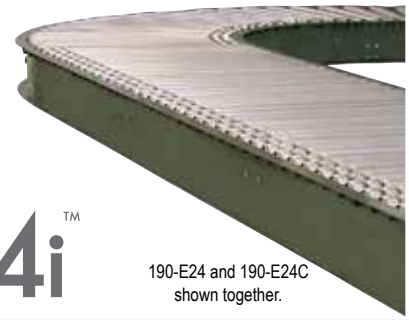

190-E24 and 190-E24C shown together.

Section Length	Between Rail Width	9"	11"	13"	15"	17"	19"	21"	23"	25"	27"	31"	33"	37"	39"
	Overall Frame Width	12"	14"	16"	18"	20"	22"	24"	26"	28"	30"	34"	36"	40"	42"
10'-0"	Weights (lbs.)	285	300	310	325	340	355	370	385	400	410	435	450	480	495
Per Foot	Weights (lbs.)	16	17	19	20	21	23	24	26	27	28	31	32	35	36

- NOTE:**
- Section Lengths are available from 2 ft. to 10 ft, in 6 in. increments.
  - Motors are mounted on various centers, and will slave a maximum of 16 rollers. Includes: motor, control board, o-rings, frame and slaved rollers.

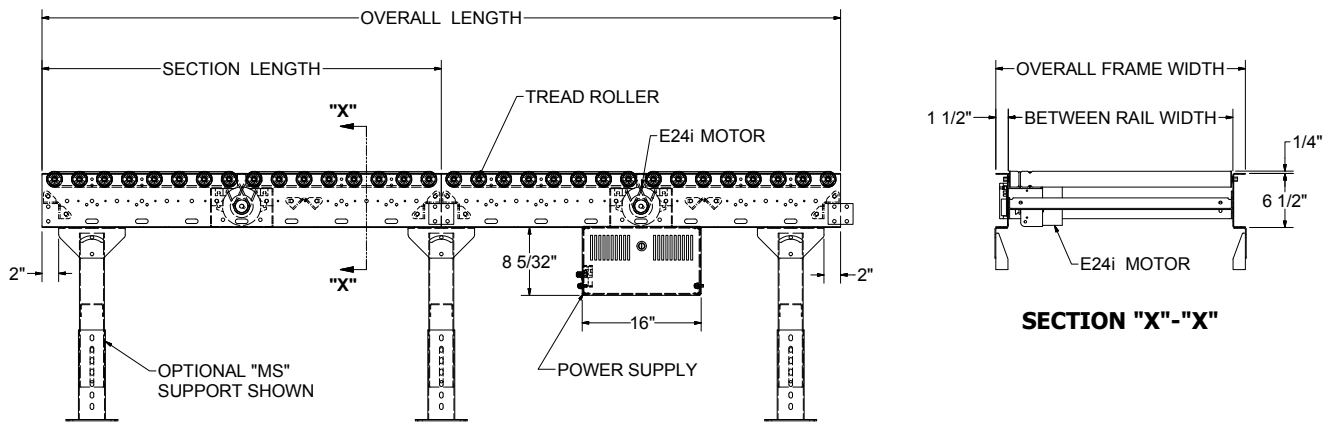

# 190-E24C

## 24 VDC Live Roller Curve Conveyor

- All-Electric Operation
- Adjustable MS-Type Floor Supports Available



Between Rail Width	Overall Frame Width	"R"	Number of Rollers	90° & 60° WEIGHTS (Lbs.)	45° & 30° WEIGHTS (Lbs.)
9"	12"	24"	16	160	88
11"	14"			180	99
13"	16"			200	110
15"	18"			220	121
17"	20"			240	132
19"	22"			260	143
21"	24"	32 1/2"	20	280	154
23"	26"			300	165
25"	28"			310	171
27"	30"			325	178
31"	34"			495	274
33"	36"			48"	30
37"	40"	565	311		
39"	42"	590	325		

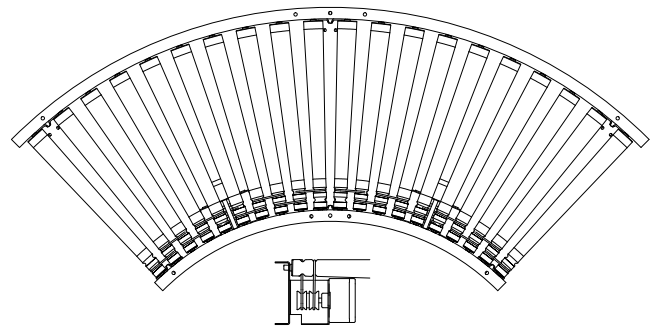

9" BR has an outside mounted motor and uses Hytrol's 3.0 card.  
 All weights in catalog are conveyor weights only.  
 Accessories, crating, etc., are not included.



## • STANDARD SPECIFICATIONS

**BED (E24)**—Roller bed with 1.9 in. dia. roller x 16 ga. galvanized tube and bearings spaced every 3 in. Mounted set-high in 6 ½ in x 12 ga. powder painted formed steel channel frame bolted together with splice plates.

**BED (E24C)**—Roller bed with 2 ½ in. dia tapered to 1 11/16 in. dia. x 14 ga. galvanized rollers. Mounted in 6 ½ x 12 ga. powder painted formed steel channel frame.

**MOTOR**—24 VDC motor with integrated control card located along section on the inside of the BR on straight section only. Maximum slaved rollers is 16 per each motor.

**SLAVE O-RINGS**—3/16 in. dia. polyurethane o-rings slave-drive tread rollers from motor.

**POWER SUPPLY (FOR MOTORS)**—40 amp DC power supply, 24 volt fixed output. Maximum of 40 motors per power supply. 120 vac, 8.6 amp input. Mounted near center of conveyor. **Note:** Number of motors per power supply is based on the use of standard Hytrol o-rings. Other o-rings are available that may increase load capacity, but reduce the number of motors that may be powered from one power supply. Contact factory for more information.

**CONVEYING SPEED**—25-254 FPM, set on integrated motor control card.

**CAPACITY**—Maximum 37 lbs. per foot with a maximum capacity per E24 motor of 75 lbs. If loading product “back to back” use the following chart:

SECTION LENGTH	NUMBER OF MOTORS IN SECTION	CAPACITY (LBS PER FOOT)
2'-0"	1	37
2'-6"		30
3'-0"		25
3'-6"		21
4'-0"	2	19
4'-6"		33
5'-0"		30
5'-6"		27
6'-0"		25
6'-6"		23
7'-0"	3	21
7'-6"		20
8'-0"		19
8'-6"		26
9'-0"		25
9'-6"		23
10'-0"		22

**NOTE:** Capacity is based on the use of standard Hytrol o-rings. Other o-rings are available that may increase load capacity, but reduce the number of motors that may be powered from one power supply. Contact factory for more information.

**FLOOR SUPPORTS**—Now supplied as optional equipment.

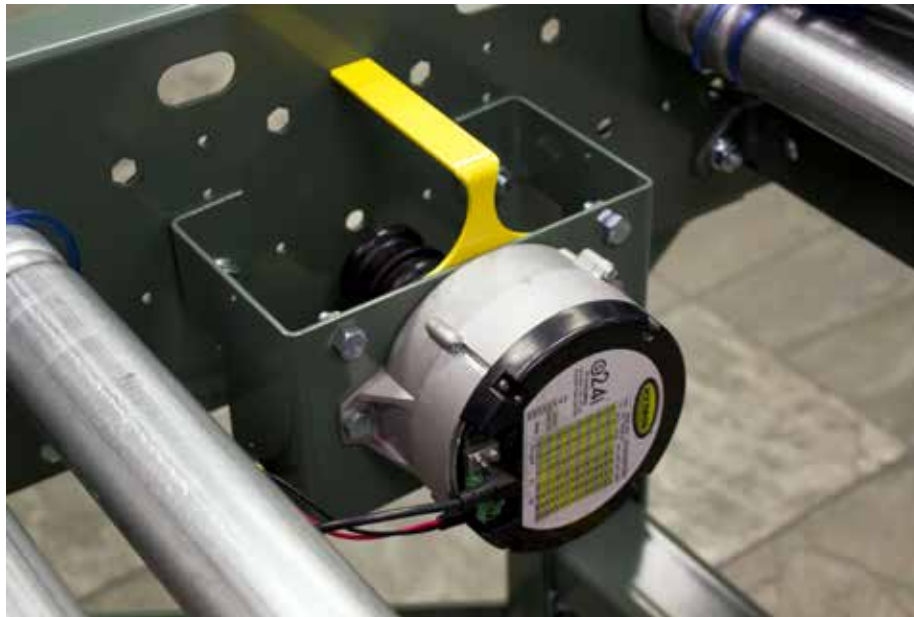

## • OPTIONAL EQUIPMENT

**FLOOR SUPPORTS**—MS Type floor supports are available with a wide range of adjustment. Specify top of belt or roller elevation. One support required at every bed joint and ends of conveyor. Holes in feet for lagging to floor. Knee braces recommended above MS-6 support.

**POWER SUPPLY (MOTORS)**—20 Amp power supply available. 20 motors maximum. 5 AMP power supply available. 3 motors maximum. 480 Volt Power Supplies also available.

**POLY-TIER SUPPORTS**—36 in. to 120 in. support heights in 6 in. increments. Knee braces required.

**CEILING HANGERS**—5/8 in. dia. x 8 ft. long unplated steel rods fully threaded. Other lengths and galvanized rods available.

**GUARD RAILS**—Adjustable Universal Channel Guard Rail, type A & B angle. (See Accessory section.)

**NOTE:** If product comes in contact with guard rails, product flow will be affected.

**MOTOR AND SEPARATE CONTROL CARD**— Available with 3 Amp setting.

**TANGENTS**— Slaved and Powered type available.

Motors mounted on outside of channel.