

ROLLER

Gravity Roller Conveyor
(2 1/2 in. Dia. x 11 Ga. Rollers)
(2 5/8 in. Dia. x 7 Ga. Rollers)

Over All Width	Between Rail Width	Model No.	Roller Centers	Weights (Lbs.)		Model No.	Roller Centers	Weights (Lbs.)	
				5'	10'			5'	10'
16 1/4"	13"	25SR-13-3	3"	185	364	26SR-13-3	3"	217	427
		25SR-13-4	4"	155	303	26SR-13-4	4"	179	351
		25SR-13-6	6"	125	242	26SR-13-6	6"	141	274
18 1/4"	15"	25SR-15-3	3"	200	390	26SR-15-3	3"	235	465
		25SR-15-4	4"	170	330	26SR-15-4	4"	200	390
		25SR-15-6	6"	135	260	26SR-15-6	6"	160	305
20 1/4"	17"	25SR-17-3	3"	215	420	26SR-17-3	3"	260	515
		25SR-17-4	4"	180	350	26SR-17-4	4"	220	430
		25SR-17-6	6"	145	280	26SR-17-6	6"	175	330
22 1/4"	19"	25SR-19-3	3"	234	458	26SR-19-3	3"	282	553
		25SR-19-4	4"	192	375	26SR-19-4	4"	228	446
		25SR-19-6	6"	151	292	26SR-19-6	6"	175	340
24 1/4"	21"	25SR-21-3	3"	245	480	26SR-21-3	3"	310	591
		25SR-21-4	4"	200	390	26SR-21-4	4"	260	510
		25SR-21-6	6"	160	310	26SR-21-6	6"	205	380

26 1/4"	23"	25SR-23-3	3"	260	510	26SR-23-3	3"	285	629
		25SR-23-4	4"	210	410	26SR-23-4	4"	230	450
		25SR-23-6	6"	165	320	26SR-23-6	6"	178	346
28 1/4"	25"	25SR-25-3	3"	282	552	26SR-25-3	3"	346	679
		25SR-25-4	4"	230	447	26SR-25-4	4"	277	542
		25SR-25-6	6"	177	342	26SR-25-6	6"	268	405
30 1/4"	27"	25SR-27-3	3"	297	594	26SR-27-3	3"	310	710
		25SR-27-4	4"	235	460	26SR-27-4	4"	270	530
		25SR-27-6	6"	180	350	26SR-27-6	6"	205	400
34 1/4"	31"	25SR-31-3	3"	312	636	26SR-31-3	3"	410	743
		25SR-31-4	4"	267	519	26SR-31-4	4"	326	638
		25SR-31-6	6"	203	391	26SR-31-6	6"	243	471
36 1/4"	33"	25SR-33-3	3"	345	678	26SR-33-3	3"	390	780
		25SR-33-4	4"	265	520	26SR-33-4	4"	310	610
		25SR-33-6	6"	200	390	26SR-33-6	6"	235	460

All weights in catalog are conveyor weights only. Accessories, crating, etc., are not included.

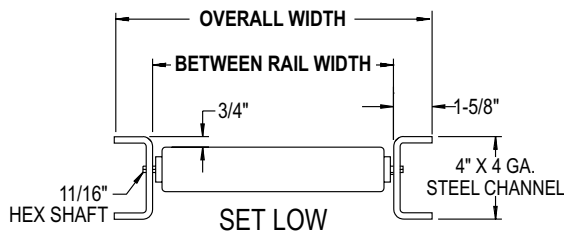
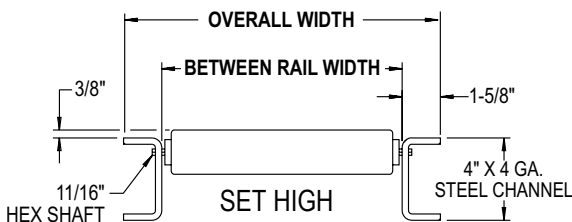

Over All Width	Between Rail Width	Model No.	Roller Centers	Weights (Lbs.)		Model No.	Roller Centers	Weights (Lbs.)	
				5'	10'			5'	10'
40 1/4"	37"	25SR-37-3	3"	355	700	26SR-37-3	3"	380	819
		25SR-37-4	4"	285	560	26SR-37-4	4"	305	600
		25SR-37-6	6"	215	420	26SR-37-6	6"	230	446
42 1/4"	39"	25SR-39-3	3"	375	740	26SR-39-3	3"	405	857
		25SR-39-4	4"	285	580	26SR-39-4	4"	325	640
		25SR-39-6	6"	220	430	26SR-39-6	6"	245	475
46 1/4"	43"	25SR-43-3	3"	415	820	26SR-43-3	3"	455	911
		25SR-43-4	4"	305	620	26SR-43-4	4"	365	720
		25SR-43-6	6"	225	450	26SR-43-6	6"	275	533
50 1/4"	47"	25SR-47-3	3"	455	900	26SR-47-3	3"	505	1017
		25SR-47-4	4"	325	660	26SR-47-4	4"	405	800
		25SR-47-6	6"	235	470	26SR-47-6	6"	305	519
54 1/4"	51"	25SR-51-3	3"	495	980	26SR-51-3	3"	555	1123
		25SR-51-4	4"	345	700	26SR-51-4	4"	445	880
		25SR-51-6	6"	245	490	26SR-51-6	6"	335	649
58 1/4"	55"	25SR-55-3	3"	535	1060	26SR-55-3	3"	605	1229
		25SR-55-4	4"	365	740	26SR-55-4	4"	485	960
		25SR-55-6	6"	255	550	26SR-55-6	6"	365	779

• STANDARD SPECIFICATIONS

WIDTHS—Between Rail Width 13 in., 15 in., 17 in., 19 in., 21 in., 23 in., 25 in., 27 in., 31 in., 33 in., 37 in., and 39 in., 43 in., 47 in., 51 in. & 55 in.

FRAME—4 in. deep x 1 3/8 in. flange x 4 ga. powder painted formed steel channel with bolt-in cross members set high, welded cross members set low.

ROLLERS—25-SR 2 1/2 in. dia. x 11 ga. steel tubing. Bearings are labyrinth sealed and grease packed.

BUTT COUPLINGS—For bolting sections together.

AXLES—1 1/16 in. hex shaft, spring loaded.

CAPACITY—See Load Capacity Chart.

LOAD CAPACITY CHART			
Support Centers	Frame Capacity (Lbs.) Maximum Distributed Live Load Per Foot	Roller Capacity (Lbs.) Maximum Load Per Roller	
		13" to 39" BR	43" to 51" BR
5'	1620	2 1/2"	2 1/2"
10'	288	630	630

• OPTIONAL EQUIPMENT

FRAME—4 in. x 5.4 lb. powder painted structural steel channel with bolt-in cross members set high, welded cross members set low.

ROLLER

Gravity Roller Curve Conveyor
 (2 1/2 in. Dia. x 11 Ga. Rollers)
 (2 5/8 in. Dia. x 7 Ga. Rollers)

Heavy-duty gravity roller curve conveyors add versatility to straight gravity roller conveyors. Curves are supplied with 2 1/2 in. dia. rollers mounted in a powder painted steel channel. Curves may be furnished with rollers set high, or with rollers set low to form 3/4 in. high guard rails.

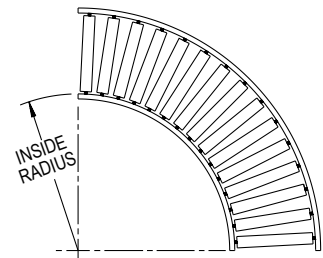

OAW	BR	Inside Radius	Rollers Per Curve 90°	Model No. 25SRC 2 1/2" Rollers	Weight (Lbs) 90°	Model No. 26SRC 2 5/8" Rollers	Weight (Lbs) 90°
16 1/4"	13"	32 1/2"	16 Single	25SRC-13-90S	170	26SRC-13-90S	196
18 1/4"	15"			25SRC-15-90S	185	26SRC-15-90S	216
20 1/4"	17"			25SRC-17-90S	200	26SRC-17-90S	235
22 1/4"	19"			25SRC-19-90S	212	26SRC-19-90S	252
24 1/4"	21"			25SRC-21-90S	230	26SRC-21-90S	274
26 1/4"	23"			25SRC-23-90S	245	26SRC-23-90S	294
28 1/4"	25"			25SRC-25-90S	260	26SRC-25-90S	313
30 1/4"	27"			25SRC-27-90S	276	26SRC-27-90S	333
34 1/4"	31"	48"	37 Double	25SRC-31-90D	432	26SRC-31-90D	505
36 1/4"	33"			25SRC-33-90D	451	26SRC-33-90D	530
40 1/4"	37"			25SRC-37-90D	589	26SRC-37-90D	578
42 1/4"	39"			25SRC-39-90D	508	26SRC-39-90D	602
46 1/4"	43"			25SRC-43-90D	546	26SRC-43-90D	650
50 1/4"	47"			25SRC-47-90D	583	26SRC-47-90D	697
54 1/4"	51"			25SRC-51-90D	622	26SRC-51-90D	746

OAW	BR	Inside Radius	Rollers Per Curve 45°	Model No. 25SRC 2 1/2" Rollers	Weight (Lbs) 45°	Model No. 26SRC 2 5/8" Rollers	Weight (Lbs) 45°
16 1/4"	13"	32 1/2"	8 Single	25SRC-13-45S	91	26SRC-13-45S	104
18 1/4"	15"			25SRC-15-45S	98	26SRC-15-45S	113
20 1/4"	17"			25SRC-17-45S	106	26SRC-17-45S	123
22 1/4"	19"			25SRC-19-45S	113	26SRC-19-45S	133
24 1/4"	21"			25SRC-21-45S	121	26SRC-21-45S	143
26 1/4"	23"			25SRC-23-45S	128	26SRC-23-45S	152
28 1/4"	25"			25SRC-25-45S	136	26SRC-25-45S	162
30 1/4"	27"			25SRC-27-45S	143	26SRC-27-45S	172
34 1/4"	31"	48"	19 Double	25SRC-31-45D	311	26SRC-31-45D	349
36 1/4"	33"			25SRC-33-45D	323	26SRC-33-45D	363
40 1/4"	37"			25SRC-37-45D	348	26SRC-37-45D	393
42 1/4"	39"			25SRC-39-45D	360	26SRC-39-45D	408
46 1/4"	43"			25SRC-43-45D	385	26SRC-39-45D	438
50 1/4"	47"			25SRC-47-45D	408	26SRC-47-45D	467
54 1/4"	51"			25SRC-51-45D	434	26SRC-51-45D	498

OAW	BR	Inside Radius	Rollers Per Curve 60°	Model No. 25SRC 2 1/2" Rollers	Weight (Lbs) 60°	Model No. 26SRC 2 5/8" Rollers	Weight (Lbs) 60°
16 1/4"	13"	32 1/2"	10 Single	25SRC-13-60S	128	26SRC-13-60S	147
18 1/4"	15"			25SRC-15-60S	138	26SRC-15-60S	162
20 1/4"	17"			25SRC-17-60S	150	26SRC-17-60S	177
22 1/4"	19"			25SRC-19-60S	159	26SRC-19-60S	189
24 1/4"	21"			25SRC-21-60S	173	26SRC-21-60S	205
26 1/4"	23"			25SRC-23-60S	183	26SRC-23-60S	221
28 1/4"	25"			25SRC-25-60S	195	26SRC-25-60S	235
30 1/4"	27"			25SRC-27-60S	207	26SRC-27-60S	250
34 1/4"	31"	48"	23 Double	25SRC-31-60D	324	26SRC-31-60D	378
36 1/4"	33"			25SRC-33-60D	339	26SRC-33-60D	398
40 1/4"	37"			25SRC-37-60D	366	26SRC-37-60D	433
42 1/4"	39"			25SRC-39-60D	381	26SRC-39-60D	451
46 1/4"	43"			25SRC-43-60D	410	26SRC-43-60D	488
50 1/4"	47"			25SRC-47-60D	438	26SRC-47-60D	523
54 1/4"	51"			25SRC-51-60D	467	26SRC-51-60D	559

OAW	BR	Inside Radius	Rollers Per Curve 30°	Model No. 25SRC 2 1/2" Rollers	Weight (Lbs) 30°	Model No. 26SRC 2 5/8" Rollers	Weight (Lbs) 30°
16 1/4"	13"	32 1/2"	5 Single	25SRC-13-30S	57	26SRC-13-30S	65
18 1/4"	15"			25SRC-15-30S	61	26SRC-15-30S	72
20 1/4"	17"			25SRC-17-30S	66	26SRC-17-30S	78
22 1/4"	19"			25SRC-19-30S	70	26SRC-19-30S	84
24 1/4"	21"			25SRC-21-30S	75	26SRC-21-30S	91
26 1/4"	23"			25SRC-23-30S	81	26SRC-23-30S	97
28 1/4"	25"			25SRC-25-30S	86	26SRC-25-30S	103
30 1/4"	27"			25SRC-27-30S	91	26SRC-27-30S	110
34 1/4"	31"	48"	13 Double	25SRC-31-30D	143	26SRC-31-30D	167
36 1/4"	33"			25SRC-33-30D	148	26SRC-33-30D	175
40 1/4"	37"			25SRC-37-30D	161	26SRC-37-30D	191
42 1/4"	39"			25SRC-39-30D	167	26SRC-39-30D	198
46 1/4"	43"			25SRC-43-30D	181	26SRC-43-30D	215
50 1/4"	47"			25SRC-47-30D	192	26SRC-47-30D	230
54 1/4"	51"			25SRC-51-30D	205	26SRC-51-30D	246

• STANDARD SPECIFICATIONS

WIDTHS—Between Rail Width 13 in., 15 in., 17 in., 19 in., 21 in., 23 in., 25 in., 27 in., 31 in., 33 in., 37 in., and 39 in., 43 in., 47 in., & 51 in.

FRAME—4 in. deep x 1 1/2 in. flange x 4 ga. powder painted formed steel channel with bolt-in cross members set high, welded cross members set low.

BUTT COUPLINGS—For bolting sections together.

CURVES—30°, 45°, 60° and 90° with 32 1/2 in. inside radius up to 27 in., 48 in. inside radius on 31 in. to 51 in. between rail widths.

ROLLERS—25-SRC 2 1/2 in. dia. x 11 ga. steel tubing. Bearings are labyrinth sealed and grease packed.

AXLES—1 1/2 in. hex shaft, spring loaded.

CAPACITY—Same per foot capacity as straight sections. See charts previous page.

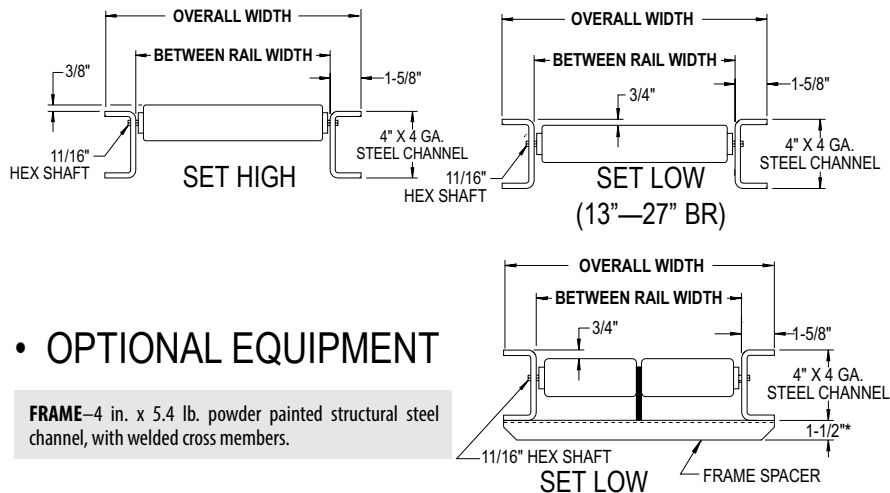

• OPTIONAL EQUIPMENT

FRAME—4 in. x 5.4 lb. powder painted structural steel channel, with welded cross members.

*Frame spacer 1 1/2" below channel on 31" to 51" BR only.

