

# A

## Aluminum Portable Narrow Belt Conveyor

The Model A, with its high grip belt, easily moves boxes, cases, and cartons up inclines. Its narrow width allows it to be used in a stairway for floor-to-floor conveying. It can be propped on a shelf for stacking or order picking. The Model A can be stored on its end in a minimum amount of space.

- Aluminum Bed
- High Grip Belt
- Electrical Controls
- Reversible



ADJUSTMENT CHART FOR 8' TO 16' LONG UNITS

Overall Length "A"	Angle of Incline	C = 19" With Roller Carriage			Angle of Incline	C = 34" With Roller Carriage		
		"D"	"E"	"F"		"D"	"E"	"F"
8'	8°	2'-7"	7'-10"	0'-3"	0°	2'-10"	8'-0"	0'-8"
	25°	4'-7"	7'-2"	0'-0"	25°	5'-11"	7'-2"	0'-8"
	30°	5'-7"	6'-10"	0'-2"	30°	6'-4"	6'-10"	0'-7"
	45°	6'-7"	5'-9"	0'-10"	43°	7'-8"	5'-10"	0'-3"
10'	8°	2'-10"	9'-10"	2'-3"	0°	2'-10"	10'-0"	2'-8"
	25°	5'-5"	9'-0"	1'-9"	25°	6'-8"	8'-11"	2'-6"
	30°	6'-1"	8'-7"	1'-6"	30°	7'-4"	8'-7"	2'-3"
	45°	7'-11"	7'-1"	0'-7"	43°	9'-0"	7'-4"	1'-9"
12'	8°	3'-2"	11'-10"	4'-3"	0°	2'-10"	12'-0"	4'-8"
	25°	6'-3"	10'-9"	3'-7"	25°	7'-7"	10'-9"	4'-3"
	30°	7'-1"	10'-3"	3'-3"	30°	8'-5"	10'-4"	4'-0"
	45°	9'-4"	8'-6"	2'-0"	43°	10'-4"	8'-10"	3'-2"
14'	8°	3'-5"	13'-11"	6'-3"	0°	2'-10"	14'-0"	6'-8"
	25°	7'-1"	12'-7"	5'-5"	25°	8'-5"	12'-7"	6'-1"
	30°	8'-1"	12'-1"	5'-0"	30°	9'-5"	12'-0"	5'-9"
	45°	10'-9"	10'-0"	3'-5"	43°	11'-9"	10'-3"	4'-8"
16'	8°	3'-8"	15'-11"	8'-2"	0°	2'-10"	16'-1"	8'-8"
	25°	8'-0"	14'-4"	7'-2"	25°	9'-3"	14'-4"	7'-2"
	30°	9'-1"	13'-9"	6'-8"	30°	10'-5"	13'-8"	7'-4"
	45°	12'-2"	11'-3"	4'-9"	43°	13'-1"	11'-8"	6'-1"

1 Week Availability

SIZE TO ORDER Overall Length "A"	"B"	WEIGHTS (Lbs.)
6'	1'-9 1/4"	145
8'	3'-9 1/4"	155
10'	5'-9 1/4"	165
12'	7'-9 1/4"	175
14'	9'-9 1/4"	195
16'	11'-9 1/4"	205
18'	13'-9 1/4"	215
20'	15'-9 1/4"	225

All weights in catalog are conveyor weights only. Accessories, crating, etc., are not included.

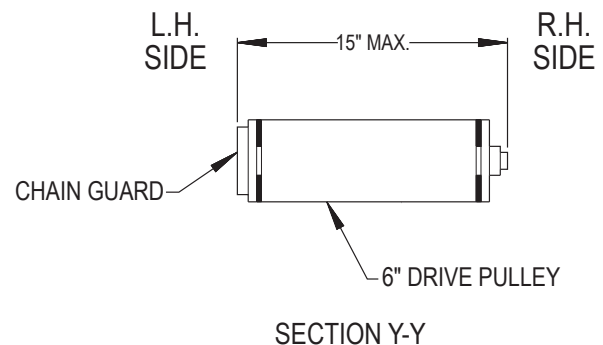
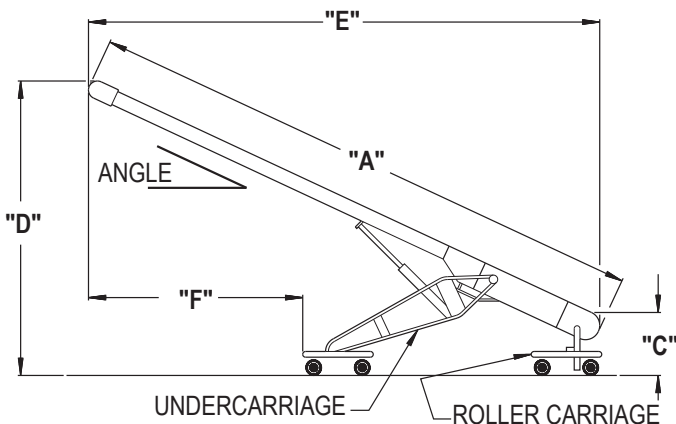
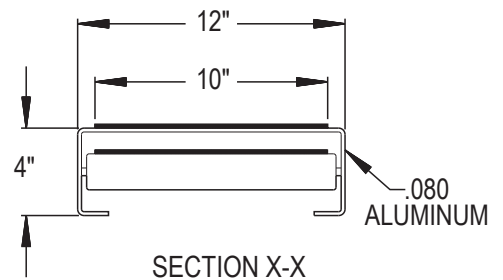
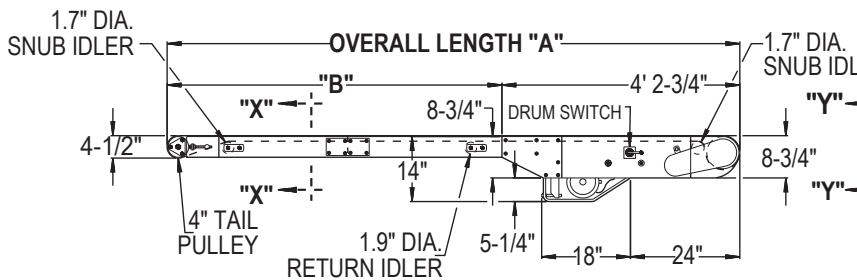

## • STANDARD SPECIFICATIONS

**BELT**—10 in. wide Black Trackmate 120 High Grip Longitudinal Groove with PVC cover. Clipper lacing.

**BED**—12 in. wide x .080 aluminum, 6061-T6 heat treated, reinforced.

**DRIVE PULLEY**—6 in. dia. with  $\frac{3}{4}$  in. dia. shaft at bearings. Machine crowned and fully lagged.

**TAIL PULLEY**—4 in. dia. with 1 in. dia. shaft at bearings, machine crowned.

**SNUB IDLER**—Adjustable 1.7 in. dia. pre-lubricated ball bearings.

**RETURN IDLER**—Adjustable 1.9 in. dia. pre-lubricated ball bearings.

**TAKE-UP**—Take-ups provided at tail pulley. Provides  $3\frac{1}{2}$  in. of belt take-up.

**BEARINGS**—Sealed, pre-lubricated ball bearings on drive and tail pulleys.

**SPEED REDUCTION**—4-step jackshaft V-belt and No. 40 roller chain.

**MOTOR**— $\frac{1}{2}$  HP—115/230V—1 Ph. 60 Hz. Totally Enclosed. Wired for 115 volt.

**ELECTRICAL CONTROLS**—Reversing drum switch with power cord and plug mounted on side shown on drawing. Specify if other side desired.

**BELT SPEED**—Constant 83 FPM.

**CAPACITY**—200 lbs. total distributed load, 120 lbs. unit load at 65 FPM.



REMOTE SWITCH  
CONTROL ROD



PERMANENT FLOOR STANDS



LOWER OR UPPER  
GRAVITY FEEDER



STAND WITH RUBBER  
WHEELS AND LOCKS

## • OPTIONAL EQUIPMENT

**CLEATED BELT**—Two  $1\frac{1}{2}$  in. dia. x  $\frac{1}{2}$  in. high cleats, fastened to belt by  $\frac{3}{8}$  in. elevator bolts spaced every 60 in. Requires gear reducer drive and spooled idlers.

**BELT SPEED**—Other constant and variable speeds. Requires gear reducer drive. NOTE: Capacity affected with speed change.

**RUBBER WHEELS**—Two 6 in. dia. x 2 in. wide with  $\frac{3}{8}$  in. dia. shaft.

**STAND WITH RUBBER WHEELS**—6 in. dia. x 2 in. wide wheels (with locks) mounted on adjustable tubular stand, 17 in. to 36 in. top of belt.

**UNDERCARRIAGE**—25 in. wide tubular steel frame with hydraulic adjustment mounted on support with 4 in. dia. steel swivel casters. See drawing and adjustment chart. Not available on 16 ft., 18 ft. & 20 ft. units.

**ROLLER CARRIAGE**—25 in. wide tubular steel support with 4 in. dia. steel swivel casters. See drawing and adjustment chart. Not available on 16 ft., 18 ft. & 20 ft. units.

**FLOOR SUPPORTS**—Adjustable steel channel with knee braces. MSAT on tail RSAD on drive.

**GRAVITY CONVEYOR BRACKET**— $\frac{1}{2}$  in. dia. rod for connecting wheel or roller conveyor.

**LOWER GRAVITY FEEDER**—2 ft. long x 12 in. wide (1  $\frac{1}{2}$ SW-12-24) includes adjustable tubular support and gravity conveyor bracket.

**UPPER GRAVITY FEEDER**—2 ft. long x 12 in. wide (3SW-12-16) includes adjustable tubular support and gravity conveyor bracket.

**LOWER POWERED FEEDER**—Chain type driven from drive pulley. 2 ft. 6 in. long belt feeder section includes adjustable tubular support and gravity conveyor bracket.

**GUARD RAILS**—Channel type, adjustable vertically and horizontally.

**STAIRWAY WALL BRACKETS**—Hinged brackets bolt to bed section and wall. Adjustable leg to rest on floor or step. Hook to hold conveyor close to wall when not in use.

**TROUGHING ATTACHMENT**—Flat steel supports under belt form trough for handling loose material. Hopper available.

**STAINLESS STEEL BED COVER**—18 ga. stainless steel skin (for ice house application).

**SELF-CLEANING DRIVE & TAIL PULLEYS**—Crowned and ribbed to prevent clogging under belt.

**GEAR REDUCER DRIVE**—Sealed worm gear speed reducer driven by motor with V-belt. Drive is bolted to bottom of bed. Standard motor support and guard not available. Affects mounting of other options. Consult factory.

**REMOTE SWITCH CONTROL**—Rod running length of conveyor to operate reverse drum switch from both ends. Switch regularly furnished on side shown on drawing. Specify if required on other side.

**MOTORS**— $\frac{1}{2}$  HP maximum.