

PCX

Low Profile Portable Parts Conveyor

The portable Model PCX parts conveyor can be easily positioned under punch presses and extruding machines to catch small steel, plastics, or aluminum stampings, etc. Conveys them quickly up to hopper or drum.

- Belt with 1" High Metal Cleats
- Underside Drive
- 3/8" High Vertical Sides Above Cleat
- Enclosed Box Construction
- Belt Scraper
- Adjustable Portable Support



Overall Frame Width	Between Rail Width	Belt Width	"A"	"B"	"C"	"D"	Weights (Lbs.)
15 1/8"	12 1/8"	12"	30"	45"	82 3/4"	32"	268
				54"	90 1/8"	37 1/4"	279
				66"	99 3/4"	44 3/8"	294
			42"	45"	94 3/4"	32"	277
				54"	102 1/8"	37 1/4"	309
				66"	111 3/4"	44 3/8"	303
21 1/8"	18 1/8"	18"	30"	45"	82 3/4"	32"	298
				54"	90 1/8"	37 1/4"	309
				66"	99 3/4"	44 3/8"	331
			42"	45"	94 3/4"	32"	309
				54"	102 1/8"	37 1/4"	323
				66"	111 3/4"	44 3/8"	342
27 1/8"	24 1/8"	24"	30"	45"	82 3/4"	32"	332
				54"	90 1/8"	37 1/4"	348
				66"	99 3/4"	44 3/8"	370
			42"	45"	94 3/4"	32"	343
				54"	102 1/8"	37 1/4"	359
				66"	111 3/4"	44 3/8"	381

All weights in catalog are conveyor weights only. Accessories, crating, etc., are not included.

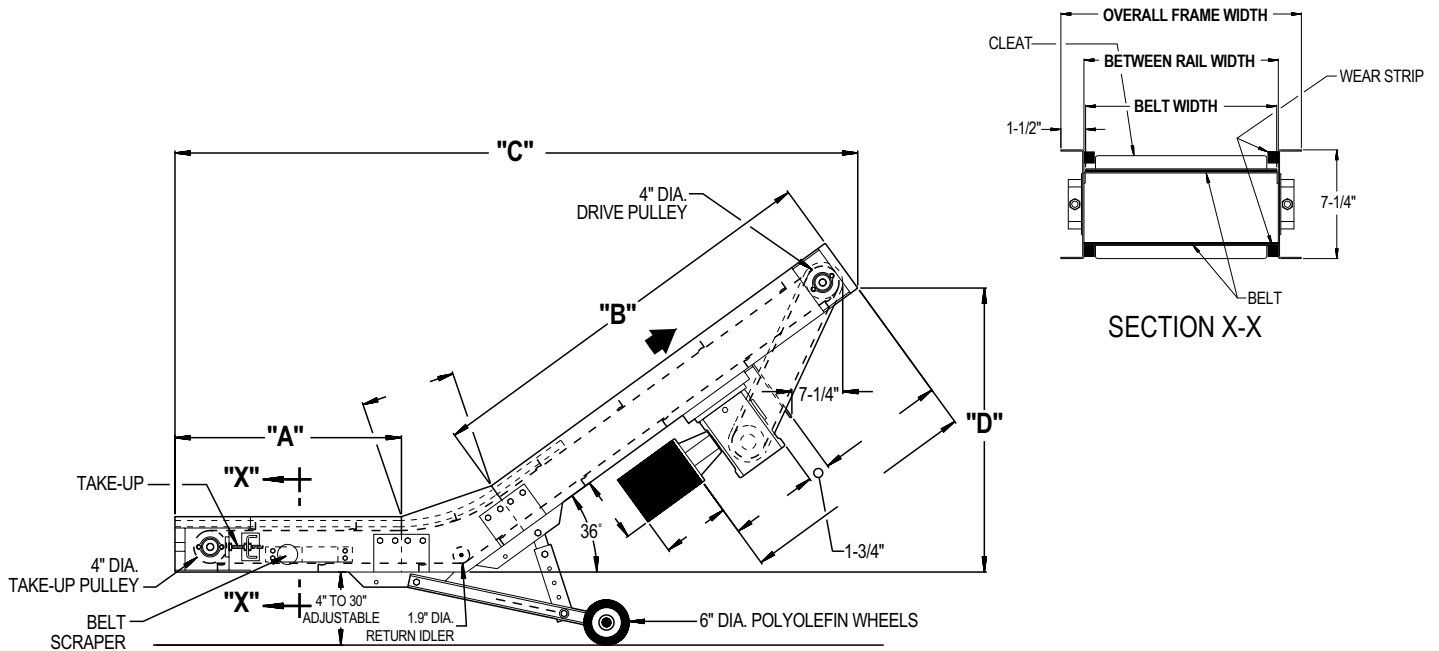

• STANDARD SPECIFICATIONS

END DRIVE—Located on discharge end of conveyor. Chain guard located on left hand side.

BELT—Black Trackmate 533 COS-PVC (cover one side) with 1" high steel angle cleats on 12" centers.. Clipper lacing.

BED—7 ¼ in. x 12 ga. powder painted steel, formed side channel with bolted in slider bed which provides 1 in. high sides above belt.

BELT SCRAPER—Mounted inside conveyor bed section to clean underside of return belt.

PORTABLE SUPPORT—Undercarriage is adjustable from 4 in. to 30 in. with 6 in. dia. rubber wheels.

DRIVE PULLEY—4 in. dia. with 1 in. dia. shaft at bearings, machine crowned and fully lagged.

TAIL PULLEY—4 in. dia. with 1 in. dia. shaft at bearings, machine crowned.

BELT RETURN—Belt cleats slide on flat metal return guide.

TAKE-UP—Take-ups at tail pulley. Provides 6 in. of belt take-up.

BEARINGS—Sealed, pre-lubricated ball bearings on drive and tail pulleys.

SPEED REDUCTION—Sealed worm gear C-Face speed reducer. No 50. roller chain to drive pulley

MOTOR—½ HP—208/230/460/575V—3 Ph. 60 Hz. Totally Enclosed C-Face.

BELT SPEED—Constant 25 FPM maximum.

CAPACITY—100 lbs. total distributed live load.

• OPTIONAL EQUIPMENT

FLOOR SUPPORTS—MS Type floor supports are available with a wide range of adjustment. Specify top of belt or roller elevation. One support required at every bed joint and ends of conveyor. Holes in feet for lagging to floor. Knee braces recommended above MS-3 support.

OVERHEAD END DRIVE—Motor reducer unit mounted 9 ¼ in. above cleat.

V-BELT DRIVE—V-belt supplied between motor and reducer.

O-RING DRIVE CHAIN—With sealed in lubricant (Recommended for applications that do not permit regular lubrication).

INCLINE—45° in place of standard 36° requires 15 ¾" incline section. Other horizontal and incline lengths available.

MOTORS—Energy efficient, single phase, brakemotor, other characteristics. 1 HP maximum.

ELECTRICAL CONTROLS—One direction manual start switch, non-reversing magnetic starters, push button stations, power cord. AC variable frequency drive.