

PLATED HEAVY GUARDRAIL GATE

PART#: HGG-2-INSIDE LENGTH-48-PLATED

WRITE REQUIRED INSIDE CLEARANCE:
 (READ SIZE CHART BELOW)

STANDARD LENGTHS	
REQUIRED INSIDE CLEARANCE	MINIMUM INSTALL LENGTH
4'-0"	7'-0"
6'-0"	9'-0"
8'-0"	11'-0"
10'-0"	13'-0"
12'-0"	15'-0"
NOTE ADD 3' FOR CUSTOM MINIMUM INSTALL LENGTH	

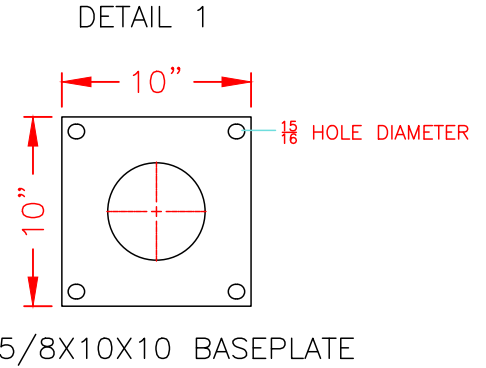
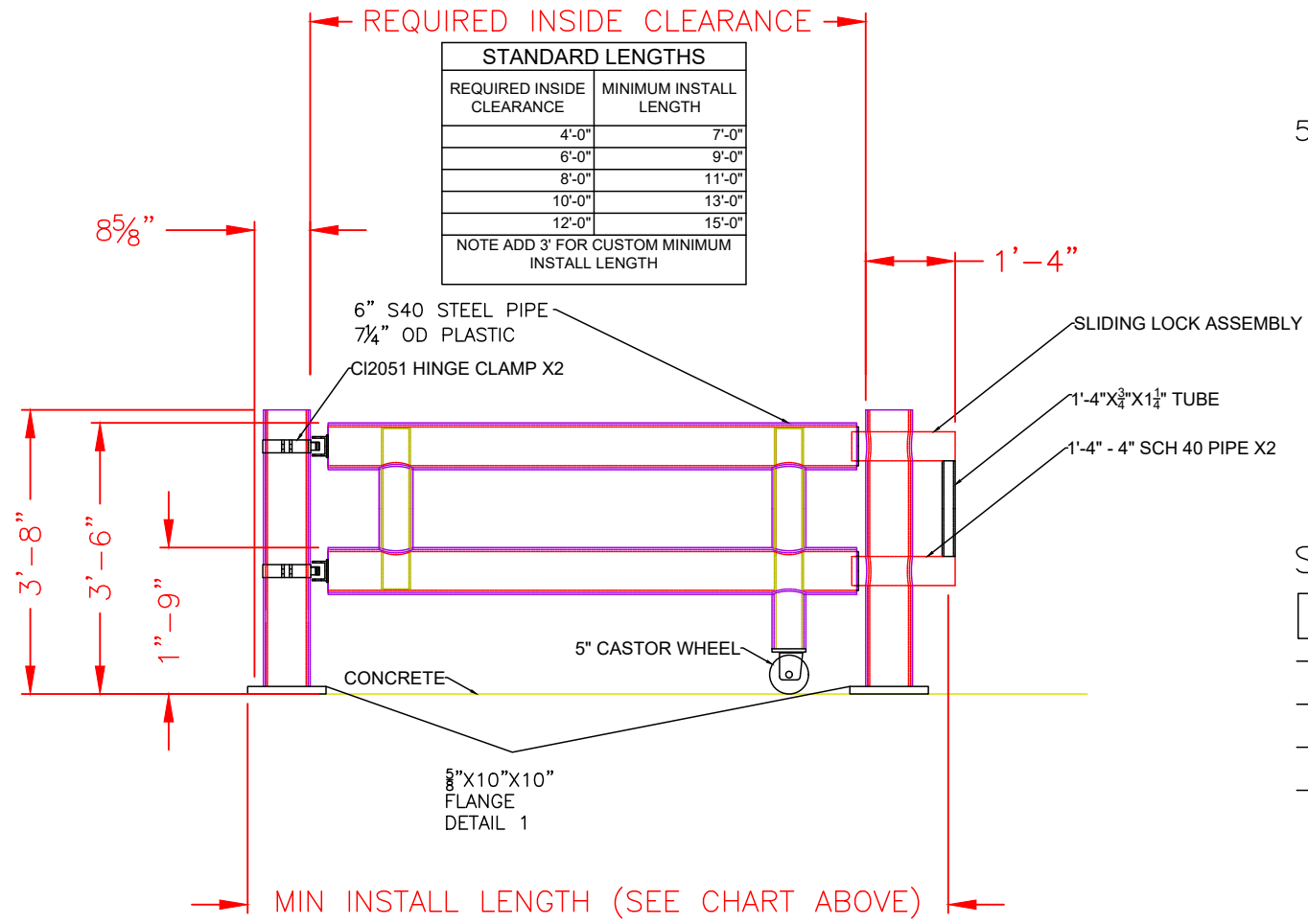

SPECIAL INSTRUCTIONS:

qty.

NO.	REVISIONS	DATE	APPROVED	PROJECT	CUSTOMER	DESCRIPTION	DRAWN BY: D.P.	APPROVED BY:	DATE:

***SIGNATURE REQUIRED FOR SUBMITTAL**

PROJECT NO.: --	SCALE: NA
DRAWING NO.:	SHEET 1 OF 1
PIPE & PLASTIC	