

# IDEAL SHIELD CORED STANDARD GUARDRAIL GATE

PART#: SGG-2-INSIDE LENGTH-48-CORED

WRITE REQUIRED INSIDE CLEARANCE:   
(READ SIZE CHART BELOW)

STANDARD LENGTHS	
REQUIRED INSIDE CLEARANCE	MINIMUM INSTALL LENGTH
4'-0"	6'-9"
6'-0"	8'-9"
8'-0"	10'-9"
10'-0"	12'-9"
12'-0"	14'-9"
NOTE ADD 2'-9" FOR CUSTOM MINIMUM INSTALL LENGTH	

DETAIL 1

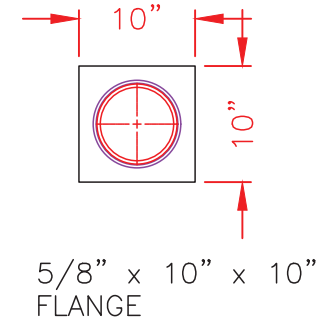

CI2051 HINGE CLAMP X2

8 5/8"

6" S40 STEEL PIPE  
7/4" OD PLASTIC

4" S40 STEEL PIPE  
5/4" OD PLASTIC

2.5" S80 STEEL PIPE  
3-3/4" OD PLASTIC

SLIDING LOCK ASSEMBLY  
(HOT DIP GALVANIZED FINISH)

1'-4" X 3/4" X 1 1/4" SQUARE TUBE

1'-4" - 2.5" SCH 40 PIPE X2

CONCRETE 5" CASTOR WHEEL

5/8" x 10" x 10"  
FLANGE  
DETAIL 1

WRITE IN  
DESIRED CORE  
DEPTH

MIN INSTALL LENGTH (SEE CHART ABOVE)

SPECIAL INSTRUCTIONS:

qty.

YES  STEEL FLOOR SLEEVE (7" ROUND)  
NO



THIS DRAWING AND ALL THE INFORMATION THEREON IS THE PROPERTY OF THE IDEAL SHIELD. IS CONFIDENTIAL AND MUST NOT BE MADE PUBLIC, NOR COPIED, NOR USED, TO THE DISADVANTAGE OF SAID IDEAL SHIELD AND IS SUBJECT TO RETURN ON DEMAND.

COPYRIGHT 2003 IDEAL SHIELD

NO.	REVISIONS	DATE	APPROVED

**IDEAL SHIELD**  
2525 Clark St.  
Detroit, MI 48209

PROJECT	CUSTOMER

DESCRIPTION
CORED GOAL POST WITH STANDARD GATE CUSTOM

DRAWN BY	APPROVED BY	DATE
D.P.		
PROJECT NO.		SCALE: NA
DRAWING NO.		
MATERIAL: PIPE & PLASTIC		
SHEET 1 OF 1		