

# Pair Folding Gates: 8'-20' Wide

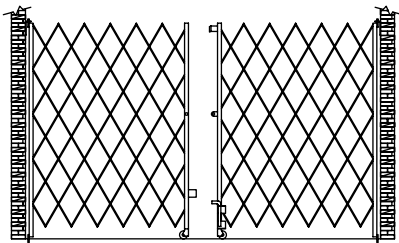

## Finished Assembly



## Parts Included

- 2" Standard L-bracket (2)
- Bearing Washer (2)

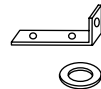

## Tools Needed

- 3/4" Masonry Drill Bit 
- 1/4" Masonry or Wood Drill Bit 

## Parts Needed

- 5/16" x 2" Long Lag Bolt
- Masonry Door Frame or Wall Installations (wall installation may require lead anchor)

## INSTALLATION INSTRUCTIONS

- 1) Before installing, decide on gate placement. L-brackets that form top hinge allow gate placement in the recess of door frame. Installation can also be made outside or inside of wall next to door or opening frame. (See Figure 1)

NOTE: Either side of gate can be toward the outside of building. A label on the operating side the side with the center drop pins indicates RHT (right) or FT (left) of a person facing the operating side.

- 2) Have a helper extend the gate and stand it upright where it will be mounted. Drill 3/4" diameter x 3" deep hole, 1/4" from wall into the floor for gate pin to set into. Place a bearing washer over floor hole and set bottom gate pin into floor mount hole. (See Figure 2)

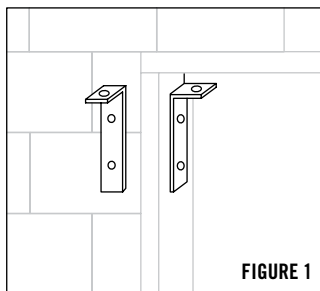

FIGURE 1

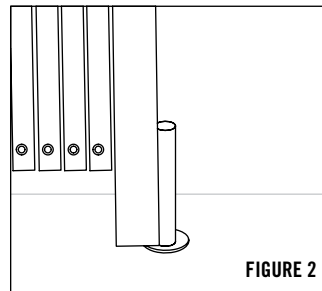

FIGURE 2

- 3) Extend gate and hang L-bracket on top of gate to verify where it will be mounted. To release tension you may lift the wheel 1/2"-3/4" off the floor. Mark and drill pilot holes into door frame or wall. It may be easier to drill pilot holes if you remove the gate from its floor mount. Place bearing washer and bottom gate pin back into floor mount. Slip L-bracket over top of gate and bolt (not included.) (See Figure 3)

- Wood door frames or walls: 5/16 x 2" lag bolts.
- Steel door frames or walls: Drill & tap for 5/16" x 2" lag bolts.
- Brick or concrete frames or walls: 5/16" x 2" Lag bolts set into 3/8" holes with lead anchors.

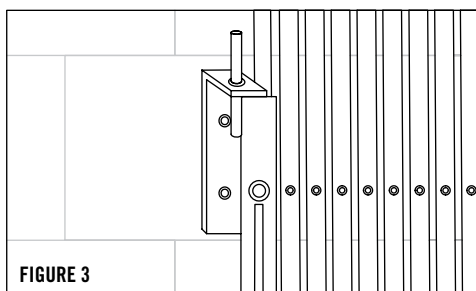

FIGURE 3

- 4) Raise center drop pin and use attached notch to keep in place; this prevents damage to floor surface. (See Figure 4) Extend and retract gate to its stops to work out stiffness. Repeat steps 2-3 for other half of gate.

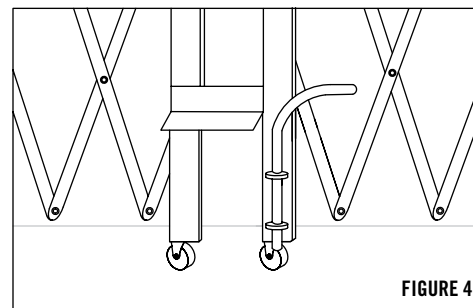

FIGURE 4

- 5) With center drop pin raised, extend both halves of gates together to center of opening, mark floor for center drop pin hole and drill a 3/4" diameter x 3" deep hole. Lower center drop pin (Note: some larger gates have an additional web in the center of each web, mark and drill these last.) Open gates slowly to avoid warping. (See Figure 5)

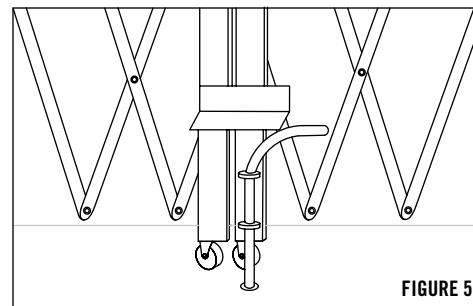

FIGURE 5

### FOR GATES 12 TO 20 FEET:

Only gates 12' to 20' and wider include a center drop pin. If included, fully extend gate across opening and mark the floor where center drop pin is located. Drill a 3/4" diameter x 3" deep hole into the concrete floor. Lower center drop pin. (See Figure 6)

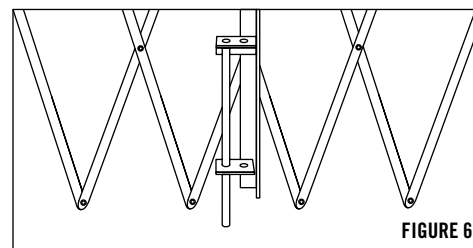

FIGURE 6