

## **Stainless pallet truck - hygienic pallet transport**

Optimum hygiene - with a stainless pallet truck the risk of bacterial contamination is minimized. The stainless products were developed in cooperation with a Creamery for use in environments where the hygiene demands are severe and where the truck is exposed to an aggressive environment and thorough cleaning.

No damage to surroundings, pallets and goods  
- Panther Inox Plus and Panther Inox have elegant design with rounded corners.

The design prevents industrial injuries and strain on the user - focus is put on safety and ergonomic working conditions of the user. The ergonomically correct shape of the handle ensures a relaxed hold for the user.

High quality is ensured through an extended test program and in cooperation with experts in Health and Safety.



### Technical Specifications

The stainless pallet truck is available in two models:

- **Inox Plus:** Acid-resistant fork chassis. All other parts stainless steel
- **Inox:** Acid-resistant fork chassis. Stainless handle, wheel forks, lifting arm and thrust plate. The push rod has a polymer plastic coating and the pump is chromit-treated.

Easy to clean and optimum resistance

- acid-resistant and electric polished fork chassis
- strong surface
- corrosion resistant

Long operating life and low maintenance costs

- strong construction
- AISI316L steel used on the fork chassis
- many options for lubricating



Inox Plus - for the food industry and the pharmaceutical industry with strict hygiene and sanitation requirements.



Inox - for the food industry in areas, where hygiene demands are not so high, but corrosion resistance important.



Completely open or completely closed truck elements facilitate efficient cleaning.



The lowered height can be adjusted.



The pallet truck is also available with different wheels.

Product (measured in inch)	Panther Inox Plus PIP2072	Panther Inox Plus PIP2082	Panther Inox PI2082	
Capacity in lbs.	4400	4400	4400	
Lifting height	$h_3$	$h_{13} + 4.75$		
Fork length	$l$	32, 36, 38, 45, 48, 60		
Overall height	$h_1$	$h_{13} + 16.25$		
Fork span	$b_5$	20.5, 27		
Length without forks	$l_2$	13.25		
Overall length	$l_1$	$l + 13.25$		
Fork width	$e$	6.25		
Wheelbase	$y$	$l + 1$		
Overall height	$h_{14}$	46		
Lowered height	$h_{13}$	3 to 3.25	3.25 to 3.5	3.25 to 3.5
Load centre	$c$	$l/2$		
Ground clearance	$m_2$	$h_{13} - 2$		
Turning angle of the wheels		220°		
Fork wheels - single	$\varnothing 2.75 \times 3.5$	$\varnothing 3.25 \times 3.5$	$\varnothing 3.25 \times 3.5$	
Fork wheels - tandem		$\varnothing 3.25 \times 2.75$	$\varnothing 3.25 \times 2.75$	
Steering wheel		$\varnothing 7.75 \times 2$		
Weight		152 lbs (20.5 x 45), 166 lbs (27 x 45)		

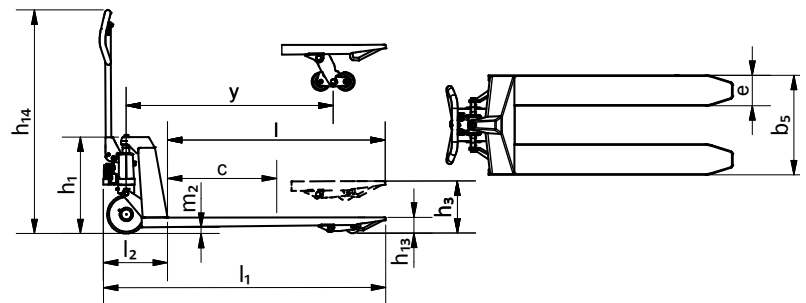

Ergonomic handle ensures the user a relaxed hold.



The pallet truck being used in the pharmaceutical industry.



Wheels with rubber-sealed bearings.

We also offer tailor-made solutions.