

# LED Forklift Safety Light and Warning Light - Model 770 BLU

## PRODUCT INFORMATION

---

<b>Description</b>	12-110V LED Blue Material Handling Safety Light
<b>Height</b>	137.16 mm / 5.4 in
<b>Width</b>	144.27 mm / 5.68 in
<b>Depth</b>	87.88 mm / 3.46 in
<b>Shape</b>	Oval
<b>Outer Lens Material</b>	Polycarbonate
<b>Outer Lens Color</b>	Clear
<b>Housing Material</b>	Polycarbonate
<b>Housing Color</b>	Black
<b>Mounting Hardware Description</b>	(x1) M10-1.5 x 25mm
<b>Mounting Type</b>	Universal Pedestal Mount
<b>Minimum Operating Temperature</b>	-40 °C / -40 °F
<b>Maximum Operating Temperature</b>	65 °C / 149 °F
<b>Connector or Wiring</b>	Integrated
<b>Mating Connector</b>	AMP (#180923)
<b>Product Weight</b>	1.31 lbs / 0.59 kgs
<b>Shipping Weight</b>	10.20 lbs / 4.63 kgs



---

**Distributed by:**

Cisco-Eagle

[www.cisco-eagle.com](http://www.cisco-eagle.com) | 888-877-3861

# LED Forklift Safety Light and Warning Light - Model 770 BLU

## PRODUCT DIMENSIONS

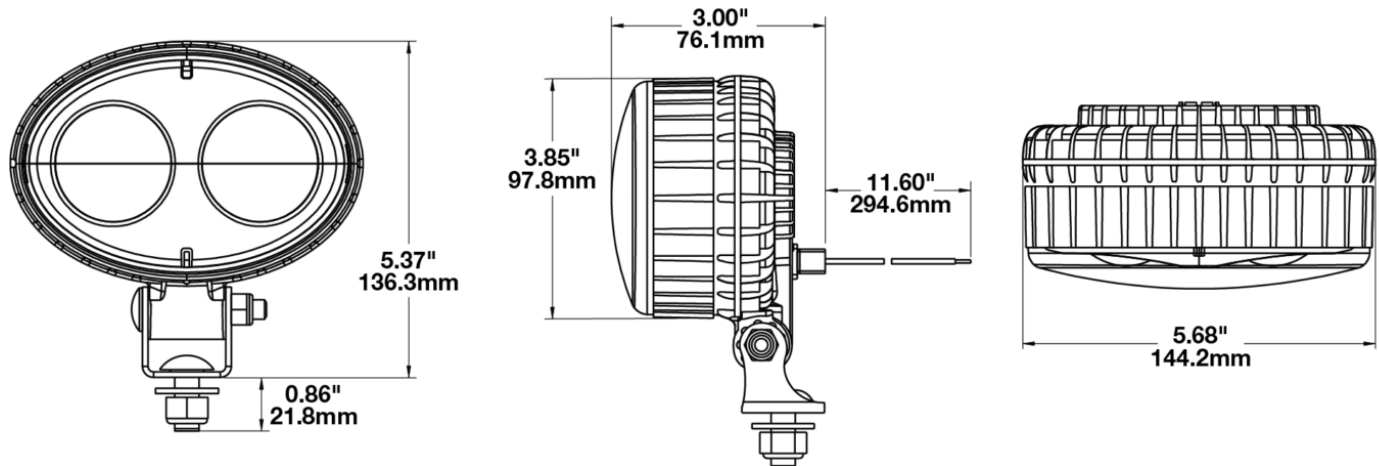

## ELECTRICAL SPECIFICATIONS

<b>Input Voltage</b>	12-110V DC
<b>Operating Voltage</b>	9-120V DC
<b>Red Wire</b>	Positive
<b>Black Wire</b>	Negative
<b>Current Draw</b>	0.50A @ 12V DC 0.12A @ 60V DC 0.08A @ 110V DC

## REGULATORY STANDARDS COMPLIANCE



Buy America Standards  
IEC IP69K  
Tested to ECE Reg. 10  
(Radiated Emissions only)

Eco Friendly  
SAE J1455  
UL Recognized

# LED Forklift Safety Light and Warning Light - Model 770 BLU

## PHOTOMETRIC SPECIFICATIONS

---

**Beam Pattern(s)** Forward Lighting - Spot

## APPLICATIONS

---



## PRODUCT WARNINGS

---

For California residents:

**⚠ WARNING:** Cancer and reproductive harm - [www.P65Warnings.ca.gov](http://www.P65Warnings.ca.gov).

**⚠ AVERTISSEMENT:** Cancer et effet nocif sur la reproduction - [www.P65Warnings.ca.gov](http://www.P65Warnings.ca.gov).