

# Pedestrian hazards around overhead cranes

New FOREWARNER-LED warning lights significantly improve awareness by pedestrians and improve operator control of hook/load with floor light frame of reference.

Industrial plants have forklifts, heavy equipment, noisy machinery and overhead cranes busily working with operators of these machines concentrating mainly on the load being handled and their job at hand. Operators are frequently multitasking and in a hurry to complete their material handling task. Pedestrian workers are also busy doing their job in the same proximity as these material handling machines.

***There are major safety hazards in play!***

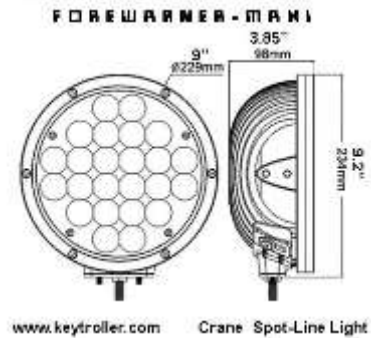

## AUDIBLE ALARMS ARE LIMITED

Audible beeping alarms have been used successfully for many decades. However audible alarms are frequently “drowned out” and ignored as workers get used to the sound especially in loud industrial settings. Today there is widespread use of worker ear plugs mandated by corporate safety to protect the worker. This problem with audible alarms is exacerbated when multiple cranes are working simultaneously in the same area.

**FOREWARNER** lights do not take the place of audible alarms, but do provide additional visual warning that is proportional to the proximity of the moving equipment hazard. An audible beeping reverse alarm serves more as a general caution to employees working in the area, however this still requires workers to identify the hazard and assess whether its proximity is dangerous. Unlike an audible “beep”----the actual movement of a light on the floor from a forklift or overhead crane provides a definitive warning to working pedestrian employees.



## Not just pedestrian safety! Operators have more control of any load!

- Reduce accidents!! 80 lift and material handling equipment workers are killed each year, on average
- Reduce incidences of human error----pedestrians are more aware of moving load
- Pedestrian workers are frequently working in close proximity to crane handling operations
- Pedestrian sees projected line or spot on floor —knows his proximity to the moving load
- Very effective for overhead cranes working in areas with many pedestrians.
- Pedestrian workers can get “immune” to the beeping sound of overhead cranes in use
- Beeping audible alarms do NOT provide a pedestrian with a sense of proximity to the load on the crane
- Crane operators have a new “frame of reference” as to the exact position of load/hook above the floor
- Significantly improves operator control of the load, especially when exact positioning is required.
- Operators do not have to take their eyes off the crane block or load to know trolley is centered over the load.
- LED lines can create a square “**box**” around the load/hook on floor---obvious “danger area”
- Pedestrian worker sees colored line or spot on the floor---knows load is moving and his proximity to it
- Snap on lens cover turns spot on the floor into line on the floor---allows user to “box” in the hook.
- Moving lines/spot on the floor prevents pedestrians from walking under suspended load.
- Operators control overhead cranes from a cab far above the floor or a pendant from operator on the floor
- When a load on a crane is stopped suddenly, there is significant hook/load sway
- Workers are concentrating on their job at hand and may NOT see the moving load in their area.
- Crane operators concentrate on the load they are handling and may NOT see workers.
- Powerful 24 MAXI LED 120 watt light projects **RED**---**BLUE** or **WHITE** spot or line (with lens cover)

**Available Models:** Volume pricing discounts available—In stock for immediate shipment

- |                           |                          |  |
|---------------------------|--------------------------|--|
| <b>FWNB-120W-MAXI-B</b>   | <b>FWNB-84W-MAXI-R</b>   | 24 LED light, 10' cable, snap on line lens cover                   |
| <b>FWNBP-120W-MAXI-B</b>  | <b>FWNBP-84W-MAXI-R</b>  | 24 LED light, 10' cable, lens cover AC/DC power supply             |
| <b>4FWNBP-120W-MAXI-B</b> | <b>4FWNBP-84W-MAXI-R</b> | (4) 24 LED lights, 10' cable, lens cover, AC/DC for 4 lights (box) |

## SPECIFICATIONS:

### BLUE or RED or WHITE Spotlight Specifications:

- Power: **120 Watts** **84 Watts** White 84 Watts
- Lumens: **12000 lm** **8400 lm** White 8400 lm
- Voltage: 9--60V DC
- LEDs: 24 (Cree LED) LED color temperature: 6000K
- Beam: Pencil spot or Line with lens cover attached
- Size: 9" X 3.9" X 9.2" (229 X 98 X 234mm)
- Waterproof: IP67 Cable Length: 3.3 meters (10').
- Working temperature: -40~85°C -40~185f
- Material: Aluminum die-cast housing.
- Approval: ISO9000--CE--RoHS
- Packaging: 2 LEDs per box with protective foam.
- Lifetime hours: up to 30,000 --- 50,000 hours
- Adjustable "U" bracket: 150 degree up/down

**VIDEO---Red linelights (4) over floor dual hook handling coil steel with "box"**

[https://youtu.be/SnYG\\_mwYN3s](https://youtu.be/SnYG_mwYN3s)



## CONCLUSION:

**MAXI Crane 24 LED** lights create significantly more pedestrian awareness by visually warning working and walking employees from being in the wrong place at the wrong time ---as well as providing the crane operator with a new visual dimension for controlling the hook or load---thus minimizing the potential of a preventable accident or damage to the load.

## Free demo!

**MAXI Crane 24 LED** lights are available to easily demo the effectiveness in your plant. Just plug in the AC/DC power supply into a 110VAC outlet and shine it up. With the line-lens cover attached, you will see the **RED** or **BLUE** line above---clearly on the ceiling. Remove the lens cover and you have a concentrated spot above. Demo units are available call 813-877-4500 or [sales@keytroller.com](mailto:sales@keytroller.com).



# KEYTROLLER

CREATING A CULTURE OF SAFETY

813-877-4500

[sales@keytroller.com](mailto:sales@keytroller.com)

[www.keytroller.com](http://www.keytroller.com)

