

# COMPLETE TOW HITCH KIT ASSEMBLY

## PARTS LIST FOR 35020, 35021 AND 35022 FULL INSTALLATION KITS

Item	Description	Qty for 36" Long Dolly	Qty for 42" Long Dolly	Qty for 48" Long Dolly	Part No.
A	Hitch bracket with pin	1	1	1	35018
B	Center support brace:				
	For 36" long dollies	1	-	-	35005
	For 42" long dollies	-	1	-	35006
	For 48" long dollies	-	-	1	35007
C	Tow arm assembly	1	1	1	35019
D	Hex head cap screw - 3/8"-16 x 1-1/4" long	4	4	4	80026
E	Hex lock nut - 3/8"-16	4	4	4	80603

### TOOLS REQUIRED

- (1) PENCIL, MARKER OR TRANSFER PUNCHES
- (1) HAMMER
- (1) PISTOL DRILL
- (1) .406Ø DRILL BIT
- (2) 9/16" SOCKETS AND/OR WRENCHES

Use this bracket as a template for drilling holes into the frame. Below is the correct bracket orientation (U-notches face up).

Center the bracket vertically and horizontally and mark hole placement. Drill holes; repeat on other end.

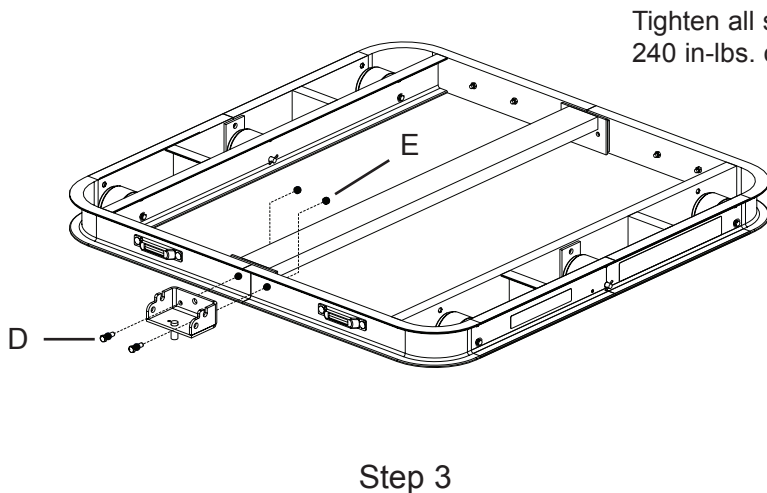
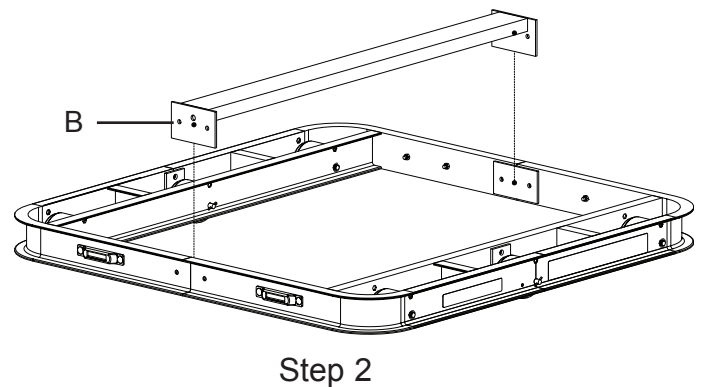
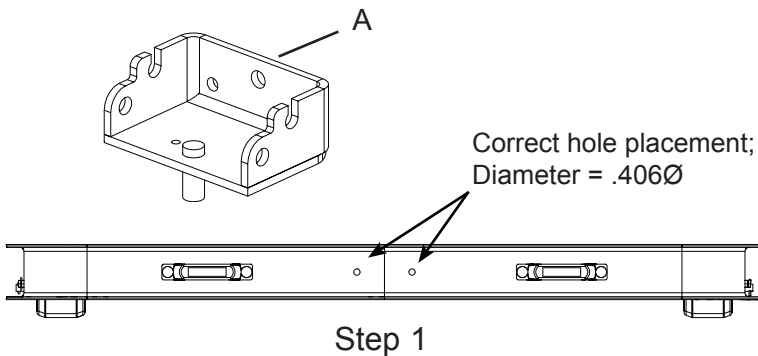

Tighten all screws to 240 in-lbs. of torque.

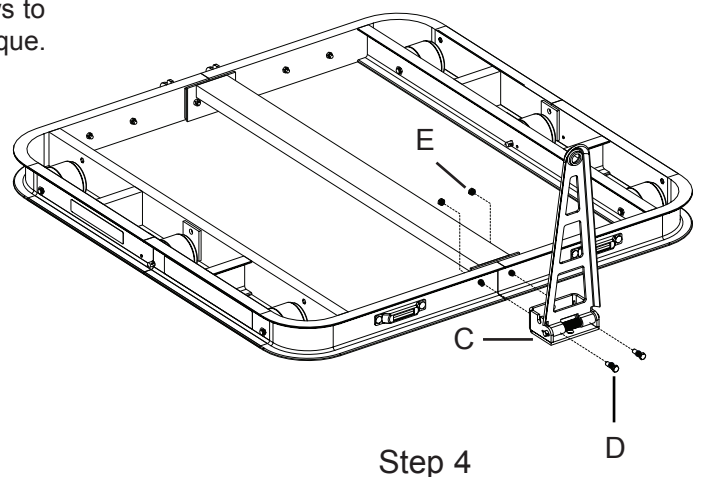

# MANUAL HANDLE KIT ASSEMBLY

## PARTS LIST FOR 35023 MANUAL HANDLE ONLY KIT

Item	Description	Qty	Part No.
A	Hitch bracket	1	35015
B	Hex head cap screw - 3/8"-16 x 1-1/4" long	2	80026
C	Hex lock nut - 3/8"-16	2	80603
D	Handle with grips	1	35014

### TOOLS REQUIRED

- (1) PENCIL, MARKER OR TRANSFER PUNCHES
- (1) HAMMER
- (1) PISTOL DRILL
- (1) .406Ø DRILL BIT
- (2) 9/16" SOCKETS AND/OR WRENCHES

The handle can be used on pallet dollies that already have the tow hitch installed and the handle can be ordered individually. Use these instructions if you are retrofitting a pallet dolly without the tow hitch option.

Use the bracket as a template for drilling holes into the frame. This is the correct bracket orientation (U-notches face up).

Center the bracket vertically and horizontally and mark hole placement. Drill holes. Tighten screws to 240 in-lbs. of torque.

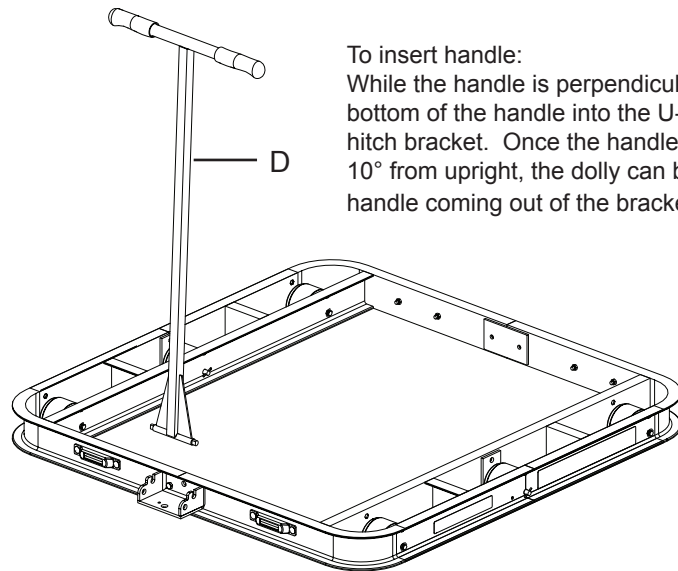
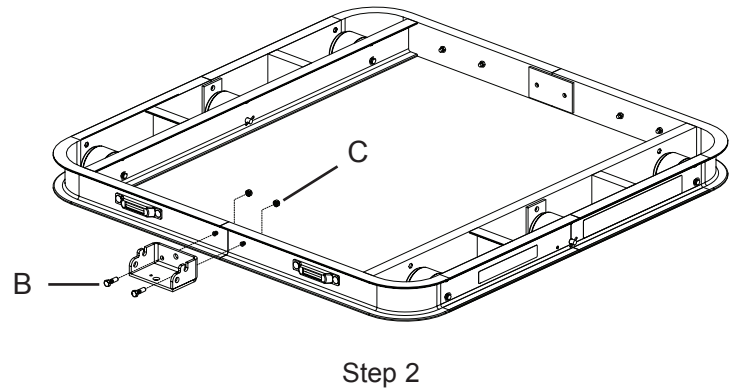
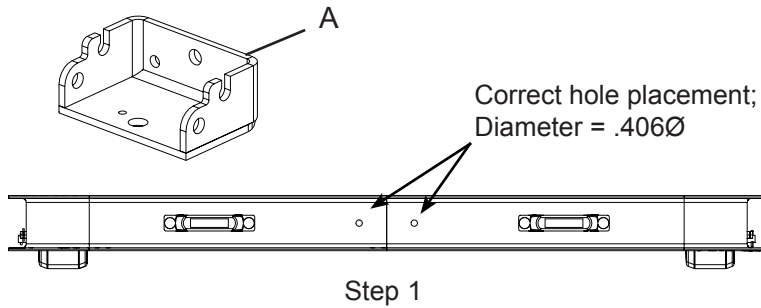

To insert handle:

While the handle is perpendicular to the ground, insert the bottom of the handle into the U-shaped notches located in the hitch bracket. Once the handle is moved forward or backward 10° from upright, the dolly can be maneuvered without the handle coming out of the bracket.

To remove handle:

Move the handle so that it is completely upright and perpendicular to the ground; lift straight up to remove from bracket.

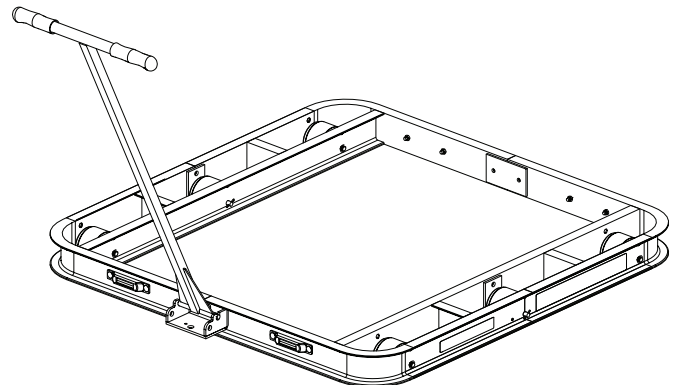

Handle/bracket interlock

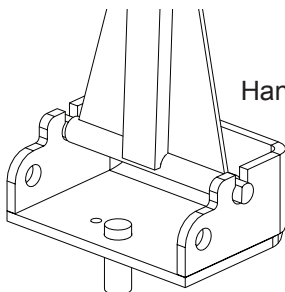

**MAGLINE, INC.**

1205 W. Cedar Street • Standish, MI 48658 USA  
 1-800-MAGLINE (624-5463) • (989) 512-1000 (outside U.S. & Canada)  
[www.magliner.com](http://www.magliner.com)