

Raise, Transport, Rotate and Drain Drum



Model 80i



Model 80i-SS
shown with
OPTION # 6075SSi-P
Stainless steel
cinch chain

- Use as a drum truck, drain stand, dolly or pump cart
- Self Supporting once loaded - No weight in the operator's hands
- Lock drum at horizontal or at 45 degrees to drain
- Lock drum upright to prevent spills
- When unlocked, tilt your drum to any angle or turn 360° to agitate
- Leverage for up to an 800 Lb. (363 kg) drum
- Install options for plastic or fiber drum
- Install Diameter Adapters for a smaller drum
- Rolls and steers easily
- Variable lift heights

Model 80i-SS
made of type 304 stainless steel
with bead blast finish

Mobile-Karrier is More than a Drum Truck

It is a drum handler with many features that make it more versatile and convenient!

It supports the full weight of your drum and transports it upright to avoid spills. Automatic handle-locks are designed to prevent unintentional lowering of the drum. Use the tilt-locks on each side to keep the drum upright, horizontal or at 45 degrees. Unlocked, the drum may be turned end-over-end to agitate contents, or may be tipped for pouring. Locked at horizontal, the drum can remain ready for dispensing with a faucet.

Morse Mobile-Karriers are extremely easy to maneuver on 8" (20.3 cm) hard, "MORTUF" polyolefin roller bearing wheels and a 4" (10.2 cm) ball-bearing swivel caster. The frame is welded structural steel for long service.

Made at our factory in East Syracuse, New York U.S.A. Ships partly assembled in a durable carton saving on freight costs.



High Strength Lifting Components

Morse models 80i and 80i-SS have a web strap and ratchet closure to secure the drum.

Model 80i solid steel 8" (20.3 cm) wide back band has the MORSE name boldly cut through it, permanently identifying it as a genuine quality Morse product.

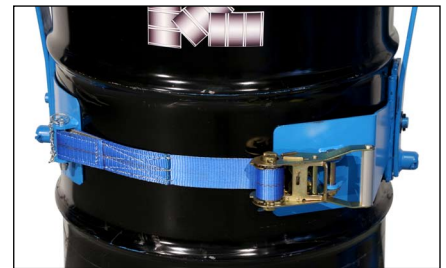

Model	Description	Handle Types of Drums
80i	Mobile-Karrier with web strap to secure drum	Handle steel 55-gallon (210 liter) drum with 22.5" (57.2 cm) outside diameter between ribs
80i-SS	Type 304 Stainless Steel Mobile-Karrier with bead blast finish. Has web strap to secure drum.	<ul style="list-style-type: none"> • Add Top Rim Clamp Kit for 55-gallon (210 liter) RIMMED plastic or fiber drum • Add Bracket Assembly Kit for RIMLESS plastic drum • Add correct size Diameter Adapter for each smaller drum

One Person Can Handle a Heavy Drum

Model 80i
shown



- **Advanced design with improved safety features.**
- **Simple to lift, move, tilt, agitate and drain heavy drum!**

Adjustable Leverage

You adjust the Morse Mobile-Karrier to do your job with minimum effort. Adjust to accommodate drum weights up to 800 Lb. (363 kg) and floor clearances of 5-1/8" to 11" (13 to 27.9 cm). Tipping capacities vary with type and amount of load carried.

Morse Drum Holders for Various Drums Sizes

The drum holder (saddle) fits a standard 55-gallon (210 liter) steel drum, and also accepts options for handling a steel, fiber or plastic drum, or Diameter Adapters for various sizes of smaller drum.

1. IT'S EASY TO SECURE THE DRUM

Roll the Mobile-karrier forward and push the drum holder into the center of the drum. The web strap of model 80i or 80i-SS is easily secured across the front of the drum with the ratchet tightener. No tools are necessary.



2. JUST PULL DOWN HANDLE TO RAISE DRUM

The drum is then raised by squeezing the two handle release rods and pulling the handle down. Automatic locks engage to hold drum up as handle is lowered. Tilt locks hold drum upright.



3. EASY TO MOVE WITHOUT SPILLING CONTENTS

With the Mobile-Karrier supporting the load, the operator can quickly and easily move it to dispensing area. Drum should always be transported in vertical position to avoid spilling.

4. DISPENSE FROM ANY POSITION

Tilt locks can be reset to automatically secure the tilted drum at horizontal for dispensing, or allow it to be turned as far as desired. Mobile-Karrier may be left holding drum for subsequent dispensing, or the drum may be easily returned to storage, freeing the Mobile-Karrier for handling other drums.

Model 80i and 80i-SS have tilt locks at upright and horizontal positions, and two additional tilt locks at 45 degrees.



Lock drum in horizontal position

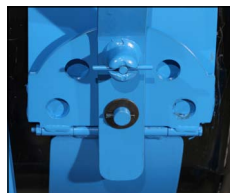

Close-up of tilt lock when drum is locked in horizontal position



Lock drum upright for safe transporting



Lock drum at 45 degrees for dispensing



Lock drum tilted at 45 degrees for access to contents

MADE
IN
USA

DIMENSIONS

FOR DRUM WITH 22-1/2" (57.2 cm) DIAMETER, 36" (91.4 cm) TALL

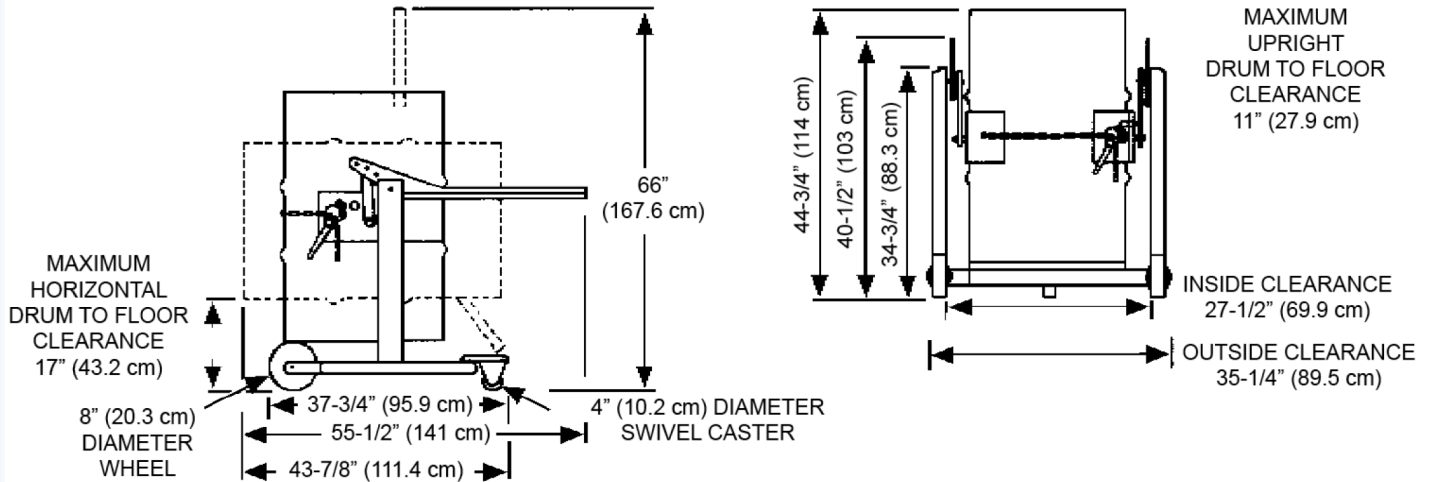

MADE
IN
USA

Options for Models 80i and 80i-SS

Bracket Assembly for Rimless Drum



The **Bracket Assembly** has a brace at top and bottom of drum to prevent it from slipping. It is **REQUIRED** for handling a rimless plastic drum, and recommended to securely handle a fiber drum. Adjusts for 31" to 39" (79 to 99 cm) tall drum.

Handle 55-gallon (210 liter) steel drum with bracket installed. Also in combination with Diameter Adapters.

Kit # 4556-P Bracket Assembly

Kit # 4556SS-P Stainless Steel Bracket Assembly

Top Rim Clamp for Rimmed Drum



The **Top Rim Clamp** grips the upper rim of drum to prevent it from slipping. Use to handle a 55-gallon (210 liter) rimmed plastic or fiber drum. To safely handle a 55-gallon plastic drum with top rim, you **MUST** install either the Bracket Assembly or the Top Rim Clamp.

Handle any RIMMED 55-gallon (210 liter) steel, plastic or fiber drum with this option installed.

Kit # 4560-P Top Rim Clamp

Kit # 4560SS-P Stainless Steel Top Rim Clamp

Cinch Chain & Ratchet



The cinch chain is more durable than the web strap, is washable and resistant to many chemicals.

Option # 6075i-P
Factory installed Cinch Chain and Ratchet

Option # 6075SSi-P
Factory installed Stainless Steel Cinch Chain and Ratchet

Diameter Adapters for Smaller Drum

Diameter Adapters insert into the drum holder to handle your smaller drum. Simply insert the correct size Diameter Adapter for your drum. Then quickly remove the Diameter Adapter to return to handling a 55-gallon (210 liter) drum.

Select the correct size Diameter Adapter for each drum. **IMPORTANT:** Measure drum diameter half-way down between the ribs (circumference divided by 3.14)

Smaller Diameter Adapters for 14 to 17.5" (35.6 to 44.5 cm) diameter drum (shown right), have integrated hold-down brackets at the top and bottom to prevent drum from slipping. The brackets adjust for a drum up to 38" (96.5 cm) tall.

For 18.5" to 22" (47 to 55.9 cm) diameter drum, use the Bracket Assembly in combination with the correct size Diameter Adapter.

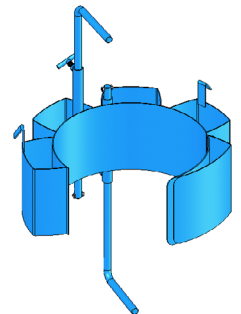

Model 55/30-16 shown

Diameter Adapters		
Diameter Adapter for Model 80i	Stainless Steel Diameter Adapter for Model 80i-SS	Fits Drum Diameter
55/30-22	55/30SS-22	21.5" to 22" (54.6 to 55.9 cm)
55/30-20.5	55/30SS-20.5	20" to 20.5" (50.8 to 52.1 cm)
55/30-19	55/30SS-19	18.5" to 19" (47 to 48.3 cm)
55/30-17.5	55/30SS-17.5	17" to 17.5" (43.2 to 44.5 cm)
55/30-16	55/30SS-16	15.5" to 16" (39.4 to 40.6 cm)
55/30-14.5	55/30SS-14.5	14" to 14.5" (35.6 to 36.8 cm)