

Super-Duty Forklift-Karriers

- **Capacity: 2500 Lb. (1134 kg)**
- **Hand operated geared tilt**
- **360° drum tilt control in both directions**
- **Quick, sure drum handling with your forklift**
- **Save time, reduce waste, improve productivity**
- **Controlled drum pouring**

MADE
IN
USA

Morse manual drum tilt Forklift-Karrier

Morse Super-Duty Forklift-Karriers have a pull chain and chain wheel for manual drum tilt control with a 20' (6 m) loop of chain to reach 10' (3 m) back to the forklift operator. There is enough resistance in the enclosed gear box to automatically stop and hold the drum tilt angle. Hand wheel tilt control option is also available.

Extra-heavy-duty construction with steel tube framework, large shafts and bearings offer long life in tough service. The oil filled, worm gear speed reducer provides 150:1 gear reduction for fine control when tipping heavy drums.

The 3-Piece Drum Holder with 2 hinged metal bands and a clamp in the front is sized for your standard ribbed 55-gallon (210 liter) 22.5" (57.15 cm) diameter steel drum.

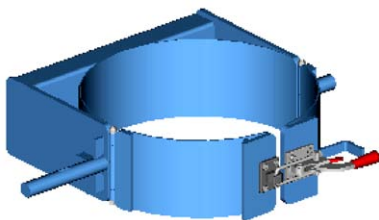

Model 285XMGR adds [spark resistant parts](#) to reduce the possibility of mechanical sparks.

Full Drum Capacity 2500 Lb. (1134 kg). Half-full drum capacity is 1250 Lb. (567 kg) Half-full rating is an indication of capacity for tilting an unbalanced, bottom-heavy drum. A partially full drum with unbalanced and shifting load is harder to tilt than full drum.

Ships fully assembled.

Dimensions

Fork pocket openings are 6.5" wide x 2.5" high (16.5 x 6.35 cm).

Fork pockets are 26.5" deep (67.3 cm).

Inside width between forks must be at least 25" (63.5 cm).

NOTE: Standard loop of pull chain extends approximately 10' (3 m) beyond the chain wheel. Custom lengths are available.

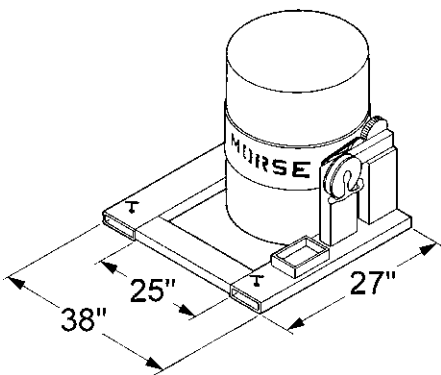

Steps to use Super-Duty Forklift-Karrier

1. Drive your truck forks into the Super-Duty Forklift-Karrier's fork pockets, then dismount and screw down the safety locks to grip the forks.
2. Drive to a drum at ground level, so that the drum holder meets the center of your drum.
3. Secure your drum in the drum holder between drum ribs... no tools are needed.
4. Raise your forklift carriage and the secured drum, then travel to the dumping location.
5. To turn the drum without leaving your forklift seat, pull the chain loop for complete control of drum tilting.
6. Lower drum to the floor, then release load binders or latch of 3-piece drum holder.
7. Loosen screw down safety locks, then back forks out of fork pockets.

Options and Accessories

- **Option X03-285XGR** - 8" (25.4 cm) Hand Wheel with speed handle. Replaces the standard chain wheel with hand wheel to turn the drum.
- **Option X03-285XMGR** - 8" Hand Wheel for model 285XMGR
- **Model 55/30-19GR Diameter Adapter.** Simply insert this Diameter Adapter into the drum holder to use model 285XGR for your 19" (48.25 cm) diameter 30-gallon (114 liter) steel drum. Quickly and easily install this Diameter Adapter in the drum holder. Then simply lift it back out to return to handling a 55-gallon (210 liter) steel drum.



Model #	Super-Duty Forklift-Karrier	19" Diameter Adapter	Unit Weight
285XGR	Forklift-Karrier with 3-piece drum holder, 2500 Lb. (1134 kg) Capacity	Model 55/30-19GR	333 Lb. (151 kg)
285XMGR	Forklift-Karrier with spark resistant parts, 3-piece drum holder, 2500 Lb. (1134 kg) Capacity	None	331 Lb. (150 kg)