

### Lift and Dispense a Drum with Your Forklift

#### Heavy-Duty Forklift-Karriers - 1500 Lb. (680 kg) Capacity

- Quickly mounts on forklift
  - No tools or truck modifications
  - No electric or hydraulic connections
- Provides controlled drum pouring
- Allows 360° drum tilt control in both directions
- Eliminates backbreaking labor and dangerous, makeshift methods
- **Model 285AM-HD has spark resistant parts**
- **Model 285A-HDSS made of stainless steel**

Morse Heavy-Duty Forklift-Karriers have a 20' (6 m) long pull chain loop with 10' (3 m) drop so you control drum tilting, 360° in either direction. Dispense a drum right from your forklift. Can also be ordered with Hand Crank or Hand Wheel option for use only within reach.

We recommend the MORStop™ Tilt-Brake option to automatically hold the drum tilt angle until operator turns it. This prevents a partially full, unbalanced drum from turning out of control, even when the contents shift from one end to the other.

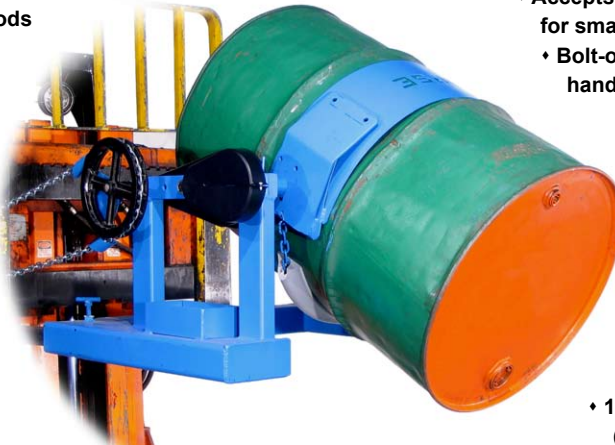

Model	Description	MORStop Tilt-Brake Option	Hand Crank Option	Hand Wheel Option	Adapters for Smaller Drum
<b>285A-HD</b>	Forklift-Karrier	3900i-P	X02-285	X03-285	55/30 Series
<b>285AM-HD</b>	Forklift-Karrier with Spark Resistant Parts	3900i-P	X02-285M	X03-285M	55/30M Series
<b>285A-HDSS</b>	Stainless Steel Heavy-Duty Forklift-Karrier	3900SSi-P	X02-285HDSS	X03-285HDSS	55/30SS Series

## MORCINCH™ Drum Handling System

- Automatically adjusts for 22" to 23.5" (56 to 59.7 cm) diameter drum
- Accepts Diameter Adapters for smaller drum
- Bolt-on Top Rim Clamp or Bracket Assembly to handle a plastic or fiber drum
- Includes flexible cover on the cinch chain to help protect drum sidewall
- Incorporates alloy cinch chain and durable stress relief weld joints
- 285A-HD, 285AM-HD, 285A-HDSS**
- Chain wheel tilt control with 60:1 gear ratio and safety cover
- Handle drum with faucet in place
- **1500 Lb. (680 kg) full-drum capacity** (800 Lb. (363 kg) half-full\* drum capacity)



Half-full rating is an indication of capacity for tilting an unbalanced, bottom-heavy drum. A partially full drum with unbalanced and shifting load is harder to tilt than a full drum.

### MORCINCH™ Drum Handling System

**Bracket Assembly** for rimless plastic drum or more securely handle a fiber drum



The **Bracket Assembly** provides a brace at top and bottom of your drum to prevent it from slipping lengthways through the drum holder. The Bracket Assembly is required to handle a rimless plastic drum, and recommended to more securely handle a fiber drum. It adjusts for 31" to 39" (79 to 99 cm) tall drum.

- Kit # 4556-P Bracket Assembly
- Kit # 4556M-P Spark Resistant
- Kit # 4556SS-P Stainless Steel

**Top Rim Clamp** for 55-gallon (210 liter) rimmed plastic or fiber drum

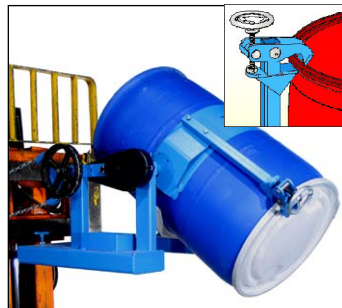

The **Top Rim Clamp** grips the upper rim of your drum to prevent it from slipping through the drum holder. Use to handle a 55-gallon (210 liter) rimmed plastic or fiber drum. To handle a 55-gallon plastic drum with top rim, you must install either the Bracket Assembly or the Top Rim Clamp.

- Kit # 4560-P Rim Clamp Assembly
- Kit # 4560M-P Spark Resistant Rim
- Kit # 4560SS-P Stainless Steel

**Diameter Adapters** for Smaller Diameter Drum



Diameter Adapters insert into the drum holder to handle a smaller drum. Select the correct size Diameter Adapter for each drum. Spark resistant and stainless steel Diameter Adapters also available.

### Installed Options

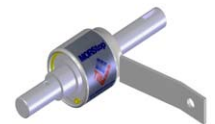

We recommend **MORStop Tilt-Brake** factory installed on your Forklift-Karrier to automatically hold the drum tilt angle.



9" Hand Crank

16" Hand Wheel



#### Web Strap and Ratchet

- Option # 5115i-P Web Strap & Ratchet
- Option # 5115Mi-P Spark Resistant
- Option # 5115SSi-P Stainless Steel

### Steps for use of Heavy-Duty Forklift-Karriers

1. Drive truck forks into the Heavy-Duty Forklift-Karrier's fork pockets.
2. Dismount and screw down the safety locks to grip the forks.
3. Drive to a drum at ground level, so that the drum holder meets the center of your drum.



4. Secure your drum in the drum holder between drum ribs... no tools are needed.

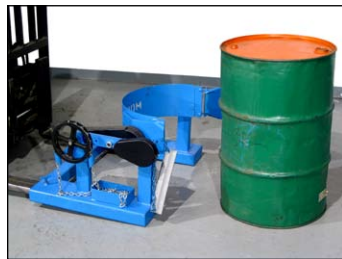

To secure drum, drape the cinch chain with flexible chain cover across the front of the drum, insert one link into the slot on the ratchet handle, and turn the ratchet handle clockwise to tighten the cinch chain around the drum.



5. If your Heavy-Duty Forklift-Karrier is so equipped, tighten the Top Rim Clamp or adjust the Bracket Assembly height.
6. Raise your forklift carriage and the secured drum, then travel to the dumping location.
7. To control turning of the drum without leaving your seat, pull the chain loop for complete control of drum tilting.



8. To remove drum from your Heavy-Duty Forklift-Karrier, turn the ratchet handle clockwise to relieve pressure on the ratchet teeth, lift pawl handle to release teeth engagement, then rotate the ratchet handle counter clockwise to loosen the chain and allow its removal from the slot on the ratchet handle.

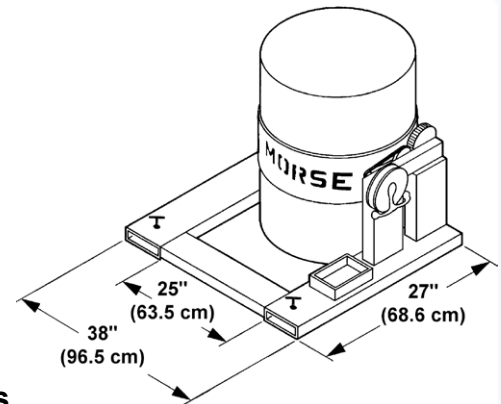
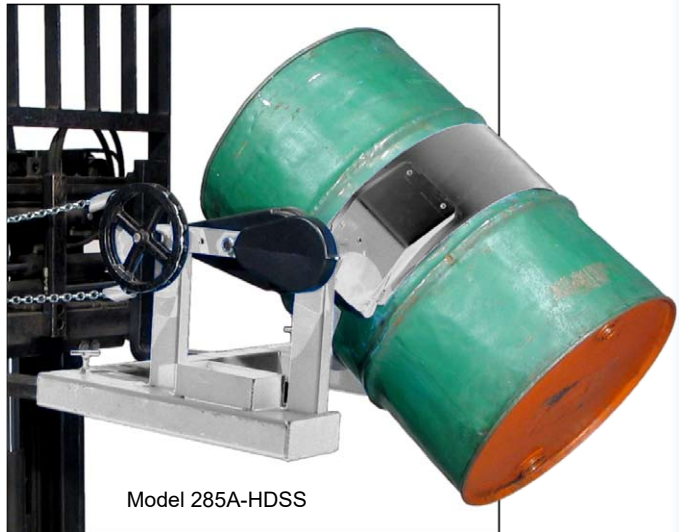

### Dimensions

**IMPORTANT:** Requires 25" (63.5 cm) Between Forks

Fork Pockets are 25" (63.5 cm) apart

Each Fork Pocket Opening:

- Model 285A-HD & 285AM-HD 6.5" wide x 2.5" high (16.5 x 6.35 cm)
- Model 285A-HDSS 5.5" wide x 2.5" high (14 x 6.35 cm)

Fork pockets are 26.5" deep (67.3 cm)

Loop of pull chain extends approximately 10' (3 m) beyond the chain wheel.

### Custom Drum Handler



**Custom model 185S-HD-FP** handles drum completely below the forks. Requires 17.5" (44.5 cm) between forks. Or use below-hook with your crane.

Use with:

- Walkie Stacker
- Forklift
- Crane or Hoist below-hook