

**Operator’s Manual for 14 Series Drum Dollies**

<b>Model 14</b>	Round Dolly for 55-gallon drum, steel casters with MORTUF polyolefin wheels
<b>Model 14-SS</b>	Round Dolly, type 304 stainless steel, for 55-gallon drum, steel casters with MORTUF polyolefin wheels
<b>Model 14-SSC</b>	Round Dolly, type 304 stainless steel, for 55-gallon drum, stainless steel casters with polypropylene wheels
<b>Model 14M</b>	Round Dolly with spark resistant parts, for 55-gallon drum, steel casters with MORTUF polyolefin wheels
<b>Model 14-30</b>	Round Dolly for 30-gallon drum, steel casters with MORTUF polyolefin wheels
<b>Model 14-30SS</b>	Round Dolly, type 304 stainless steel, for 30-gallon drum, steel casters with MORTUF polyolefin wheels

**Important**

1. Review the Material Safety Data Sheet(s) for the material(s) in the drum(s) and take all necessary precautions. Safety shoes, work gloves, hard hat and other personal protective devices are recommended.
2. Please read all instructions thoroughly before attempting to assemble or operate your new Morse drum handler.
3. The Models 14, 14-SS, 14-SSC and 14M Drum Dollies have a maximum capacity rating of 1,000 Lb. and are intended for moving a 55-gallon drum. Models 14-30 and 14-30SS Drum Dollies have a maximum capacity rating of 1,000 Lb. and are intended for moving a 30-gallon drum. DO NOT exceed this rating. Exceeding this rating, or handling drums other than those mentioned above is unsafe and could result in equipment damage, excessive wear or awkward handling.
4. When operating, loading or unloading, or maintaining your Morse drum handler, always use care, good judgement, have good footing and a firm hold to help guard against accidents.
5. Use care when pushing the dolly to maintain control and avoid tipping when rolling on rough or uneven floors. Lateral force at the top of the drum shifts over 70% of the weight to the front dolly wheels. This can make the dolly difficult to control, and potentially hazardous without warning - even topple over, especially if the dolly wheels hit an obstruction, a hole in the floor, or while descending a slope.

Decrease the risk of this happening by attaching the patent pending model # 24 **Clamp+Go Dolly Handle** (sold separately) to the drum dolly. You then pull from the bottom of the drum to move it around, with weight far more evenly distributed on all dolly wheels. You have greater control, and significantly reduce risk of tipping. The **Clamp+Go** can be used with round drum dollies of various sizes. Move the quick-pin to adjust for 2", 2.5" or 3" (5.08, 6.35 or 7.62 cm) tall dolly sidewall. One **Clamp+Go** works with all Morse round drum dollies, and with many other brands.



**WARNING:** This product can expose you to chemicals including barium sulfate, cobalt, titanium dioxide, and 2-methylimidazole, which are known to the State of California to cause cancer, and bisphenol-A, which is known to the State of California to cause birth defects or other reproductive harm. For more information go to [www.P65Warnings.ca.gov](http://www.P65Warnings.ca.gov)

**Operating Instructions**

Drum can be loaded into dolly using a Morse Model 90, or other suitable lifter for an upright drum.

**Maintenance**

1. Periodically inspect all moving parts, framework and contact areas for signs of wear, fatigue or loosening. Tighten, adjust or replace parts as necessary to prevent failure and maintain proper function.
2. The caster and wheel bearings should be checked and oiled periodically.
3. Order replacement parts through your Morse Dealer.

**Operator's Manual for 14 Series Drum Dollies**

**Assembly Instructions**

Please unpack the following parts:

- (1) Base Weldment
- (4) 3" Swivel Caster
- (16) 1/4 - 20 x 1/2" Carriage Bolt
- (16) 1/4 - 20 Rev Hex Lock Nut

1. Place base weldment (item 1) upside down so that caster mounting surfaces are facing upward.
2. Place the casters (item 2) over the pre-punched holes.
3. Push the bolts (item 3) up from below through pre-punched holes and caster plate holes. Secure with lock nuts (item 4). When assembled properly and the dolly is turned upright, the nuts will be on the underside of the dolly. The bolt heads will not interfere with the drum.

For replacement parts, please contact your Morse dealer.  
When ordering parts, please specify:

- Part number and description
- Model number

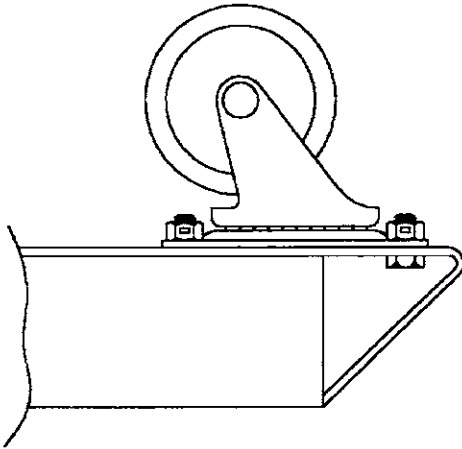
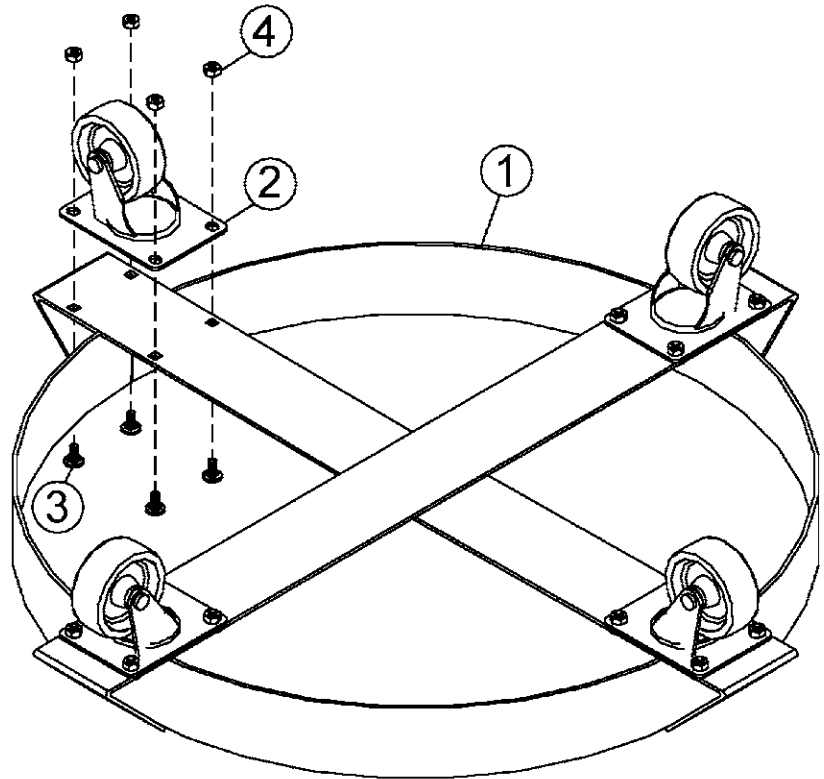

ITEM	MODEL #	QTY.	PART #	DESCRIPTION
1	14	1	1211-P	BASE WELD, 14 DRUM DOLLY
1	14-SS, 14-SSC	1	2767-P	BASE WELD, SS, 14-SS
1	14M	1	1211M-P	BASE WELD, 14 DOLLY SR
1	14-30	1	1212-P	BASE WELD, 14-30 DOLLY
1	14-30SS	1	1212SS-P	BASE WELD, 14-30SS DOLLY, SS
2	ALL (Except 14-SSC)	4	198-P	CASTER, 3", 14, 34, 201
2	14-SSC	4	198SS-P	CASTER, 3" SWIVEL, SS
3	14, 14-30	16	1317-P	BOLT, 1/4-20 X 1/2 CARRIAGE
3	14-SS, 14-SSC, 14M, 14-30SS	16	1317SS-P	BOLT, 1/4-20 X 1/2 CARRIAGE SS
4	14, 14-30	16	1297-P	NUT, 1/4-20 REV HEX LOCK
4	14-SS, 14-SSC, 14M, 14-30SS	16	1518SS-P	NUT, 1/4-20 NYLON LOCK, SS