

CONTENTS

	Page
Receiving Procedures.	1
Warranty.	1
Safety Information.	1 - 2
Machine Description.	3
Operating Instructions.	4
Maintenance.	4
Dimensions to Calculate Lost Load.	5
Parts Lists and Diagrams.	6 - 7

Operator's Manual
for Morse Heavy-Duty Forklift-Karrier
Model 285A-HD

Serial Number 1214 to ____ (MMYY)

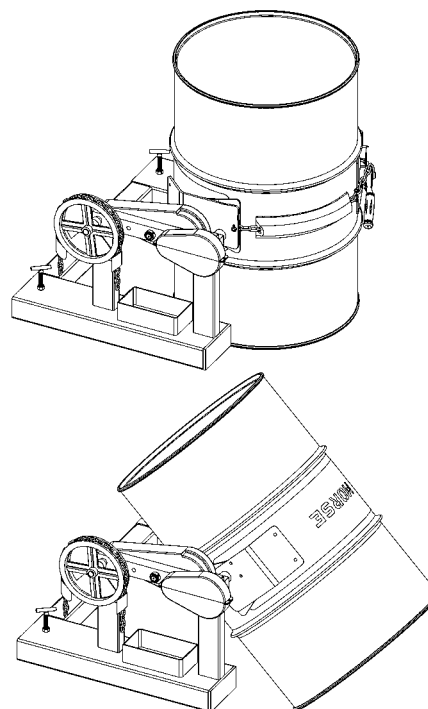

Receiving Procedures

Every Morse drum handler is inspected prior to shipping. However, damage may be incurred during transit.

- Check for visible damage. If you choose to accept damaged freight, always sign noting the damage on the **Bill of Lading**.
- Document the damage and have the truck driver sign. We recommend keeping a digital camera at your receiving dock for this purpose.
- Open packages expeditiously to check the condition of the goods. There is only a 24 hour window to notify the carrier of any concealed damage.
- Immediately **report all damage to the shipping company!** Then you may contact Morse for assistance with your freight claim.
- Morse Manufacturing will not be held responsible for any damaged freight that is not signed for as damaged.

Limited 2 Year Warranty

Morse drum handling equipment is guaranteed against defects in workmanship or materials for two years when used properly within its rated capacity. Warranty does not cover wear from normal use or damage from accident or abuse. Motors and other purchased parts carry the warranties of their manufacturers.

For warranty claims, contact your Morse Dealer to obtain a return authorization number, and for return freight advice. Return freight must be prepaid.

In all instances, liability is limited to the purchase price paid or to repairing or replacing the product. Customer assumes liability for any modifications, unauthorized repairs or parts substitution.

Safety Information

While Morse Manufacturing Co. drum handling equipment is engineered for safety and efficiency, a high degree of responsibility must be placed upon the machine operator to follow safe practices, based primarily on common sense, upon which true safety depends.

Failure to follow the safety precautions in this manual can result in personal injury or property damage. Observe the same precautions as with similar machinery where carelessness in operating or maintenance is hazardous to personnel. Carefully read the safety precautions below and throughout this manual.

Review the Material Safety Data Sheet(s) for the material(s) in the drum(s) and take all necessary precautions. Safety shoes, work gloves, hard hat and other personal protective devices are recommended.

Prior to initial use, inspect all moving parts and test rotation of chain wheel and saddle assembly. Inspect saddle assembly for proper operation. Perform necessary load test, inspections, operator training, etc.

Operator's Manual for Morse Heavy-Duty Forklift-Karrier Model 285A-HD
Serial Number 1214 to ____ (MMYY)

Safety Information (continued)

 **DANGER** - Indicates a situation which, if not avoided, will result in serious injury or death. This signal word is limited to the most extreme situations.

 **WARNING** - Indicates a situation which, if not avoided, could result in serious injury or death.

 **CAUTION** - Indicates a situation which, if not avoided, can result in damage to the machine.



WARNING - The Heavy-Duty Forklift-Karrier is designed to handle one drum of the types listed at the top of page 3. Machine Description. DO NOT attempt to handle any other type of drum or object. DO NOT exceed the weight capacity of 1500 Lb. (680 kg). Exceeding these ratings is unsafe and could result in equipment damage, excessive wear or awkward handling.



WARNING - Do Not Modify the Unit. Under no circumstances should any modifications be made to the Morse machinery without factory authorization. Any modifications may void the warranty. This machine was designed to perform a specific job and alterations may result in injury to operator or machine.



WARNING - No Loose Fitting Clothing. Wear close-fitting clothing and safety equipment appropriate to the job. Loose fitting clothing may become caught on the machinery and cause severe personal injury.



CAUTION – Do Not Transport with Drum Raised. Always lower the drum holder to lowest position before transporting.



CAUTION - Wear safety shoes with non-slip soles and hard toe protection.



CAUTION: DO NOT allow drum to impact on floor, ground, or dumping station, etc.



WARNING: This product can expose you to chemicals including barium sulfate, cobalt, titanium dioxide, and 2-methylimidazole, which are known to the State of California to cause cancer, and bisphenol-A, which is known to the State of California to cause birth defects or other reproductive harm. For more information go to www.P65Warnings.ca.gov

Operator's Manual for Morse Heavy-Duty Forklift-Karrier Model 285A-HD
Serial Number 1214 to ____ (MMYY)

Machine Description

The Model 285A-HD Heavy-Duty Forklift-Karrier is designed to lift, transport, and dispense a ribbed 55-gallon (210 liter) steel or fiber drum 22" to 23.5" (56 to 59.7 cm) in diameter. The maximum full-drum capacity is 1500 Lb. (680 kg). The capacity is derated to 800 Lb. (434 kg) for a half-full drum. The half-full rating is based on the tilt mechanism's capacity for handling an unbalanced bottom-heavy drum.



Options

- A smaller diameter drum can be handled with the correct size 55/30 Series Diameter Adaptor installed (see [Diameter Adaptor literature](#)).
- The **Bracket Assembly** (Kit # 4556-P) is **required** to handle a plastic drum without a top rim (see figure 2.1). It is also recommended to more securely handle a fiber drum. You can use the Bracket Assembly with a 55-gallon plastic, steel or fiber drum. The brace at top and bottom of the drum prevent it from slipping lengthways through the drum holder. It adjusts for a drum 31" to 39" tall.
- The **Top Rim Clamp** (Kit # 4560-P) grips the upper rim of your drum to prevent it from slipping through the drum holder (see figure 2.2). To handle a 55-gallon plastic drum with top rim, you **must** install either the Bracket Assembly or the Top Rim Clamp. You can use the Top Rim Clamp with a 55-gallon plastic, steel or fiber drum with suitable top rim.

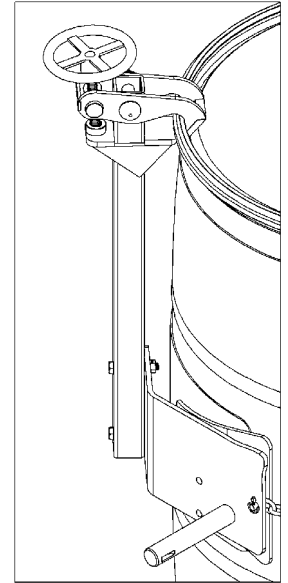
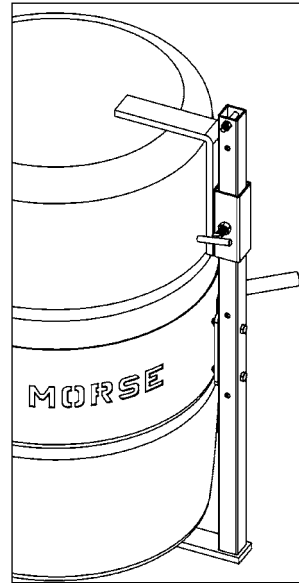
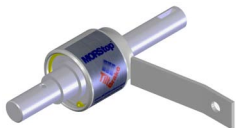

Figure 2.1
Plastic drum being lifted with Kit # 4556-P Bracket Assembly installed.

Figure 2.2
Plastic drum being lifted with Kit # 4560-P Top Rim Clamp Assembly installed.

MORStop™ Tilt-Brake
Kit # 3900-P



Kit for customer to install Tilt-Brake on EXISTING manual tilt drum handler. Automatically holds drum tilt angle until you move it.

Hand Crank or Hand Wheel
Replace standard pull chain to turn drum



9" (22.9 cm)
Hand Crank
Kit # 1460-P



16" (40.6 cm)
diameter
Hand Wheel with
speed knob
Kit # 2690-P

Important

1. Please read all instructions thoroughly before attempting to operate your new Morse drum handler.
2. When loading, unloading, operating, or maintaining your MORSE drum handler, always use care and good judgment. Maintain secure footing and a firm hold. Keep hands and loose clothing away from all moving parts. Never allow anyone to be below any part of a raised drum handler or drum. Read operating instructions and review the pictures in the sales brochure before operation.
3. This model is a front-end attachment for a forklift, OSHA recommends that "... the truck (forklift) be marked to identify the attachment(s) and show the approximate weight of the truck and attachment combination at maximum elevation with load laterally centered." See center of gravity dimensions on page 5 for calculating lost load on your equipment.

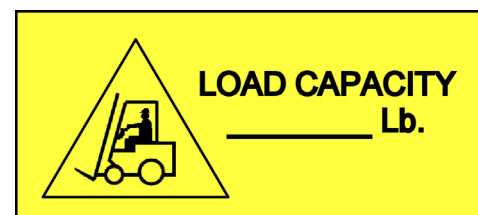

Operator's Manual for Morse Heavy-Duty Forklift-Karrier Model 285A-HD
Serial Number 1214 to ____ (MMYY)

Operating Instructions

1. Before sliding forklift forks into the fork tubes, adjust forks to an inside spread of 25" minimum. Lock forks into position on the forklift carriage.
2. Drive the forklift forward to slip the forks into the fork tubes. Tighten tee screws (item #8) to secure the Forklift Karrier to the forks.
3. Release the cinch chain (item #112) and hang the loose end from the upright peg on the front of the gear block. Swing the ratchet hinge plate to the open position.
4. Drive the forklift with the Forklift Karrier near floor level to position the saddle band around the middle of the drum between the ribs.
5. Drape the cinch chain across the front of the drum and insert one link into the slot on the ratchet handle (shown right). Turn the ratchet handle clockwise to tighten the cinch chain around the drum (see detail).
6. Remove pull chain (item #11) from chain box on base frame and place end of loop near operator's seat.
7. Raise forks to clear the floor and transport drum in vertical position to dispensing location.
8. To pour drum: pull on chain (item #11), rotating drum to angle required for dispensing. To control the pouring angle of the drum, pay out one side of chain and pull the other side to prevent the drum from free-wheeling.
9. If the Heavy-Duty Forklift-Karrier is equipped with the MORStop Tilt-Brake, there is no need to hold tension on both sides of the chain loop. Braking is immediate and self-actuating, without additional steps by the operator. To add the MORStop Tilt-Brake to your Heavy-Duty Forklift-Karrier, order kit for field installation (part # 3900-P).
10. When dispensing is completed, rotate the drum back to vertical and return drum. While transporting, ensure that the drum is raised away from the floor to prevent the drum bottom from interfering with a pallet or other obstacle.

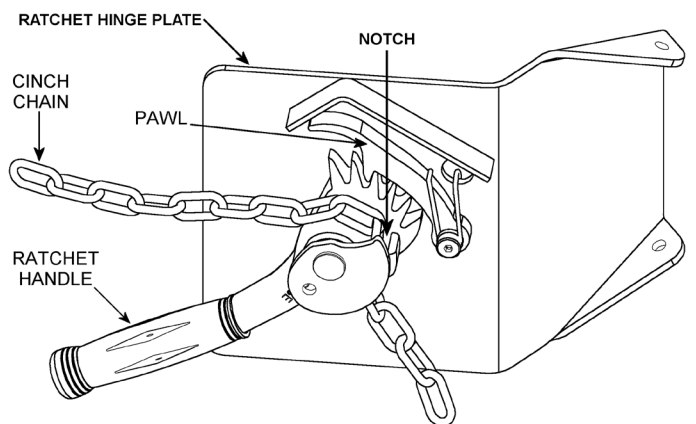
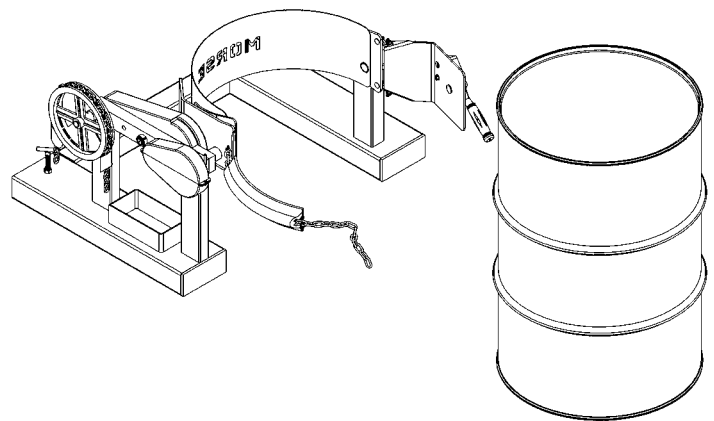
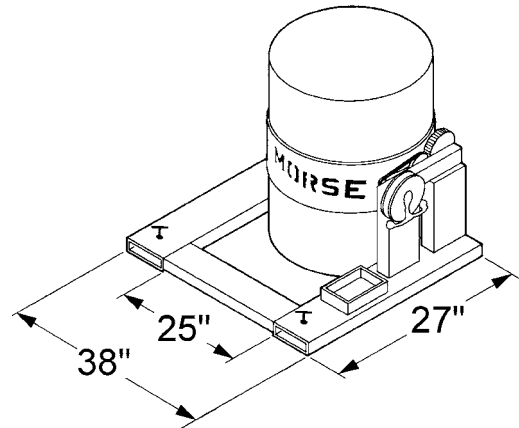

Maintenance

Periodic inspection for the general condition of structural and mechanical components is imperative for safe and efficient operation.

1. Lubricate gear teeth and roller chain.
2. Clean and oil ratchet, pawl and other moving parts periodically. Clean and lubricate more often in environments where dust, dirt or other foreign particles will effect the performance of moving parts.
3. Periodically inspect all moving parts, framework, drum holder and contact areas for signs of wear, fatigue, or loosening. Tighten, adjust, or replace parts as necessary to prevent failure and maintain proper function.
4. Worn or damaged parts must be properly replaced with the correct, genuine Morse parts.

Operator's Manual for Morse Heavy-Duty Forklift-Karrier Model 285A-HD
Serial Number 1214 to ____ (MMYY)

MORSE MODEL 285A-HD

Center of gravity shown for Morse attachment combined with max drum: 1,672lb [758kg]
 Applies to models: 285A-HD, 285AM-HD, 285G-HD and 285A-HDSS
 Approx. net weight 180 Lb. (92kg)

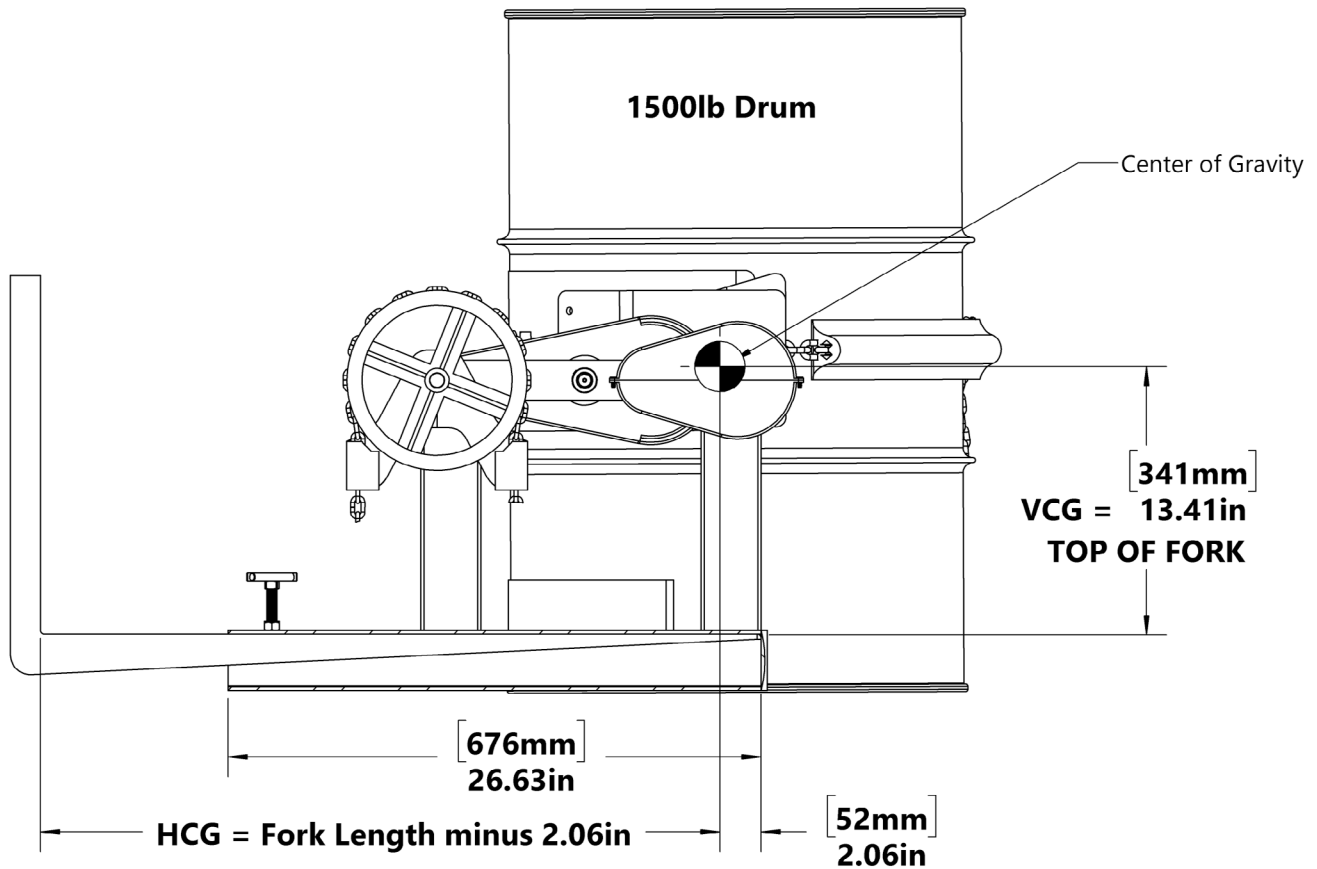

(DIMENSIONS ASSUME FORKS ARE TOUCHING FORK TUBE END CAPS.)

Operator's Manual for Morse Heavy-Duty Forklift-Karrier Model 285A-HD Serial Number 1214 to ____ (MMYY)

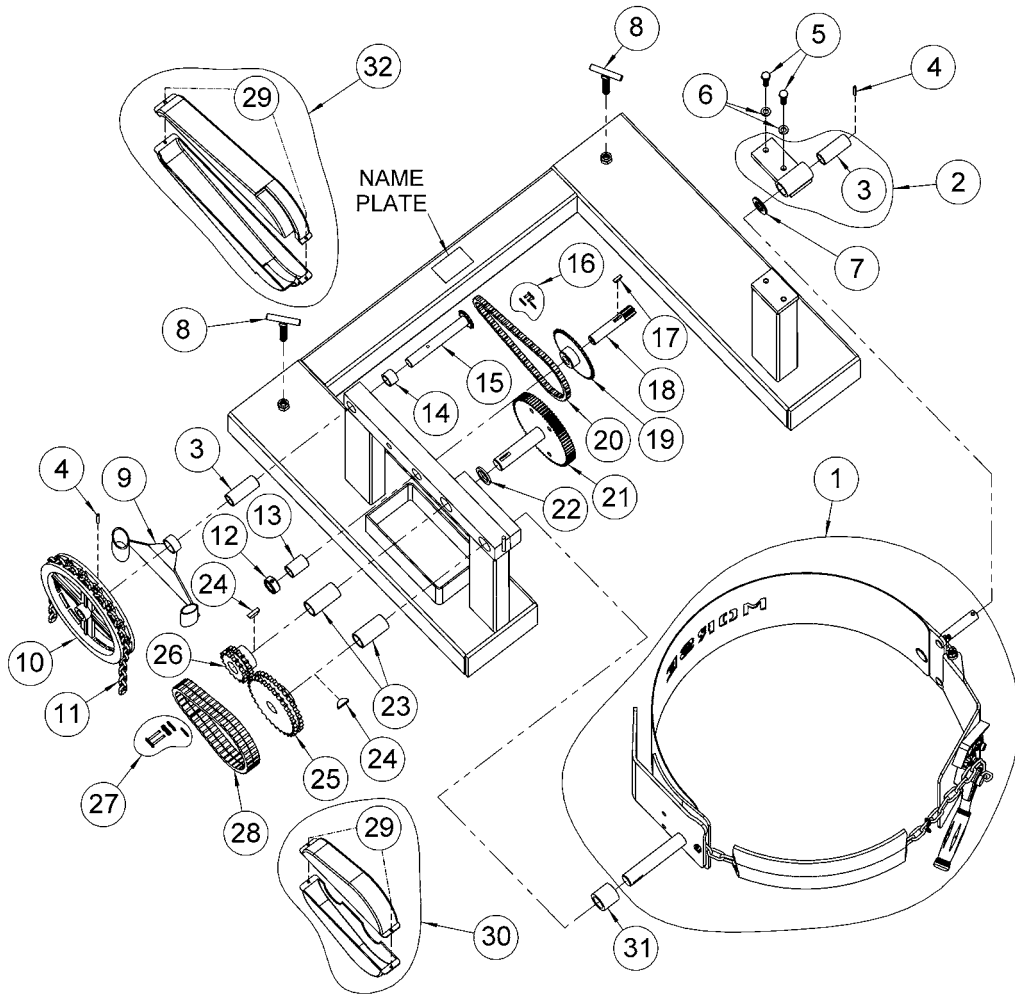

ITEM	QTY.	PART #	DESCRIPTION
1	1	5000-P	SADDLE ASM, MORCINCH, MOR
2*	1	3849B-P	BEARING BLOCK, SLIDING IDLER
3*	2	19-P	BEARING, 3/4" ID X 2-1/2"
4*	2	64-P	ROLL PIN, 3/16 X 1-1/4
5	2	535-P	HHCS, 3/8-16 X 1-1/4 GR5
6	2	1474-P	WASHER, 3/8 SPLIT LOCK
7	1	55-P	WASHER, 3/4 SAE FL 1-1/2 OD
8	2	58-P	SET SCREW, LOCK TEE, 285
9*	1	1304-P	GUIDE, POCKET CHAIN WHEEL
10*	1	1303-P	POCKET CHAIN WHEEL, 3/4 BORE
11*	1	3-285-P	CHAIN, PULL, POCKET 20' LENGTH
12	1	15-P	COLLAR, 3/4" ID
13*	1	7-P	BEARING, 3/4" ID X 1-1/2"
14*	1	1411-P	SPACER, SHAFT W/ 12T SPROCKET
15*	1	1302-P	SHAFT W/ 12T SPROCKET, POCKET
16	1	795-P	LINK, MASTER, #35 CHAIN
17*	1	735-P	KEY, WOODRUFF, SIZE 9, ASA606

ITEM	QTY.	PART #	DESCRIPTION
18*	1	14-P	GEAR, PINION, 7 TOOTH
19*	1	13-P	SPROCKET #35 36T, 3/4" BORE
20*	1	12-P	CHAIN, ROLLER, #35 W/ M LINK
21*	1	27-P	SPUR GEAR W/ 1" SHAFT, HD TYPE
22	1	29-P	SPACER, SPUR GEAR .15"
23*	2	18-P	BEARING, 1" ID X 2-1/2"
24*	2	736-P	KEY, WOODRUFF, SIZE 15, ASA808
25*	1	32-P	SPROCKET #40D 32T, 1" BORE
26*	1	30-P	SPROCKET #40D 16T, 1" BORE
27	1	796-P	LINK, MASTER, #40D CHAIN
28*	1	31-P	CHAIN, ROLLER, #40D W/ M. LINK
29	4	4481-P	SCREW, 8-18 X 5/8 FH SQUARE SS (not shown)
30	1	4284-P	COVER SET, 40D SPROCKETS
31	1	4372-P	SPACER, HD DRIVE SHAFT 1.4"
32	1	4286-P	COVER SET, 30:1 GEARS, HD

* Recommended spare parts.

Operator's Manual for Morse Heavy-Duty Forklift-Karrier Model 285A-HD
Serial Number 1214 to ____ (MMYY)

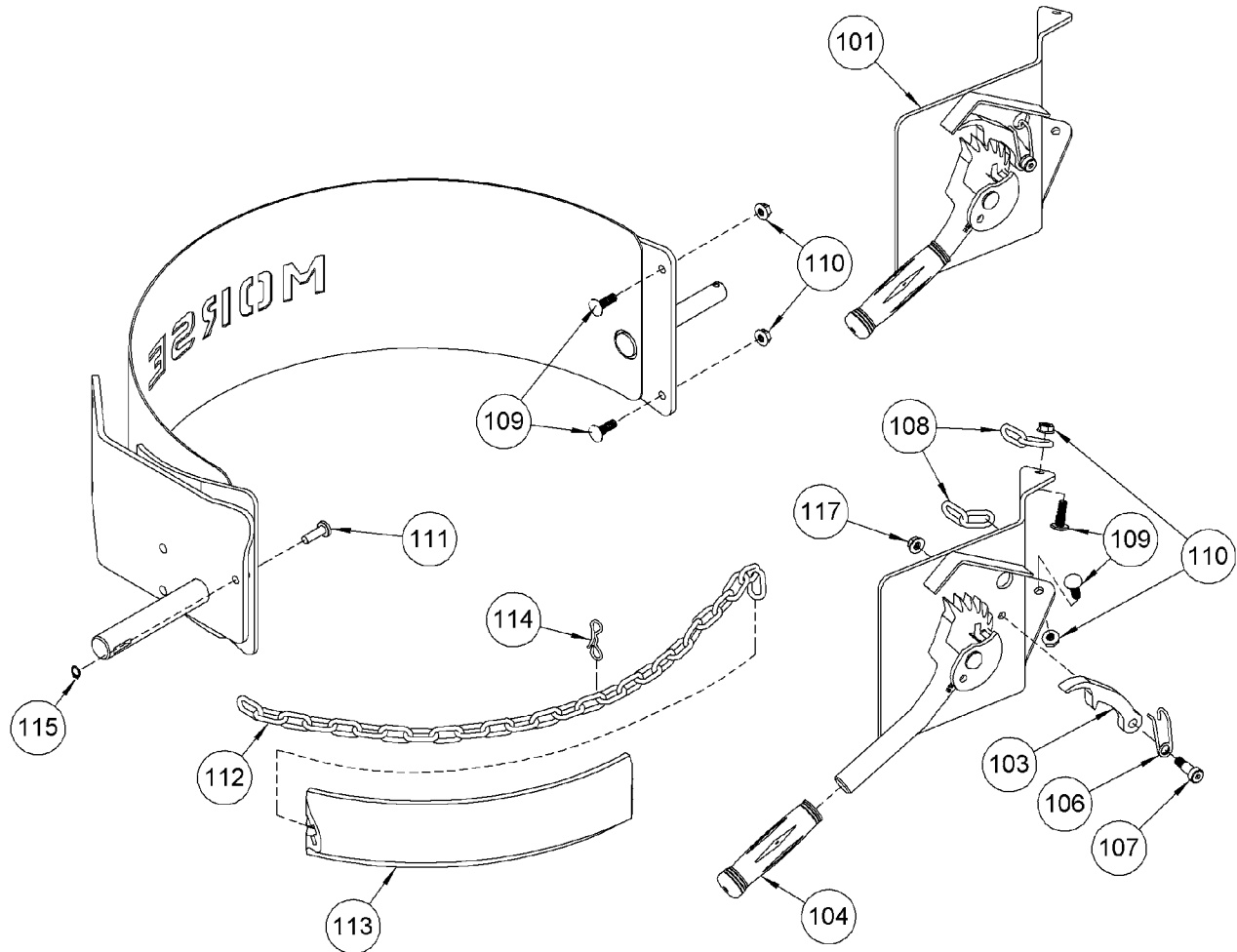

ITEM	QTY.	PART #	DESCRIPTION
101*	1	4214A-P	RATCHET PLATE CPT, MOR
103	1	168-P	PAWL, WITH DRILLED HOLE
104	1	136-P	GRIP, HANDLE 7/8" X 4-3/4"
106	1	169-P	SPRING, PAWL
107	1	170-P	SCREW, 3/8 DIA X 5/8 SHOULDER
108*	2	5019-P	CHAIN, HINGE, 9/32 ALLOY 2 LK
109*	4	4177-P	BOLT, 5/16-18 X 1 CARRIAGE RIB

ITEM	QTY.	PART #	DESCRIPTION
110*	4	4178-P	NUT, 5/16-18 FLANGE LOCK, MOR
111*	1	4172SP-P	PIN, S.P., CINCH CHAIN, 5000-P
112*	1	5017-P	CHAIN, CINCH, 9/32, 38 LINK
113*	1	4414-P	COVER, CINCH CHAIN, FLEX PVC
114	1	4710-P	PIN, BOW TIE COTTER, MOR
115*	1	4744-P	SNAP RING, EXTERNAL, 3/8"
117	1	1634-P	NUT, 5/16-18 WHIZ LOCK

* Recommended spare parts.