

Parts List and Diagram for Models 152 and 153 Drum Hand Trucks
Manufactured 03/2018 to _____

1. Slide the Handle Assembly tube through the Hook Slide Weldment (item 3) and into the Base Assembly tube and align drilled holes.
2. Insert bolt (item 5) through the aligned holes and secure with Lock Nut (item 4) to fasten the Handle Assembly to the Base Assembly.

Note: Hook Slide Weldment slides freely on the Handle assembly tube to engage the upper rim of your drum.

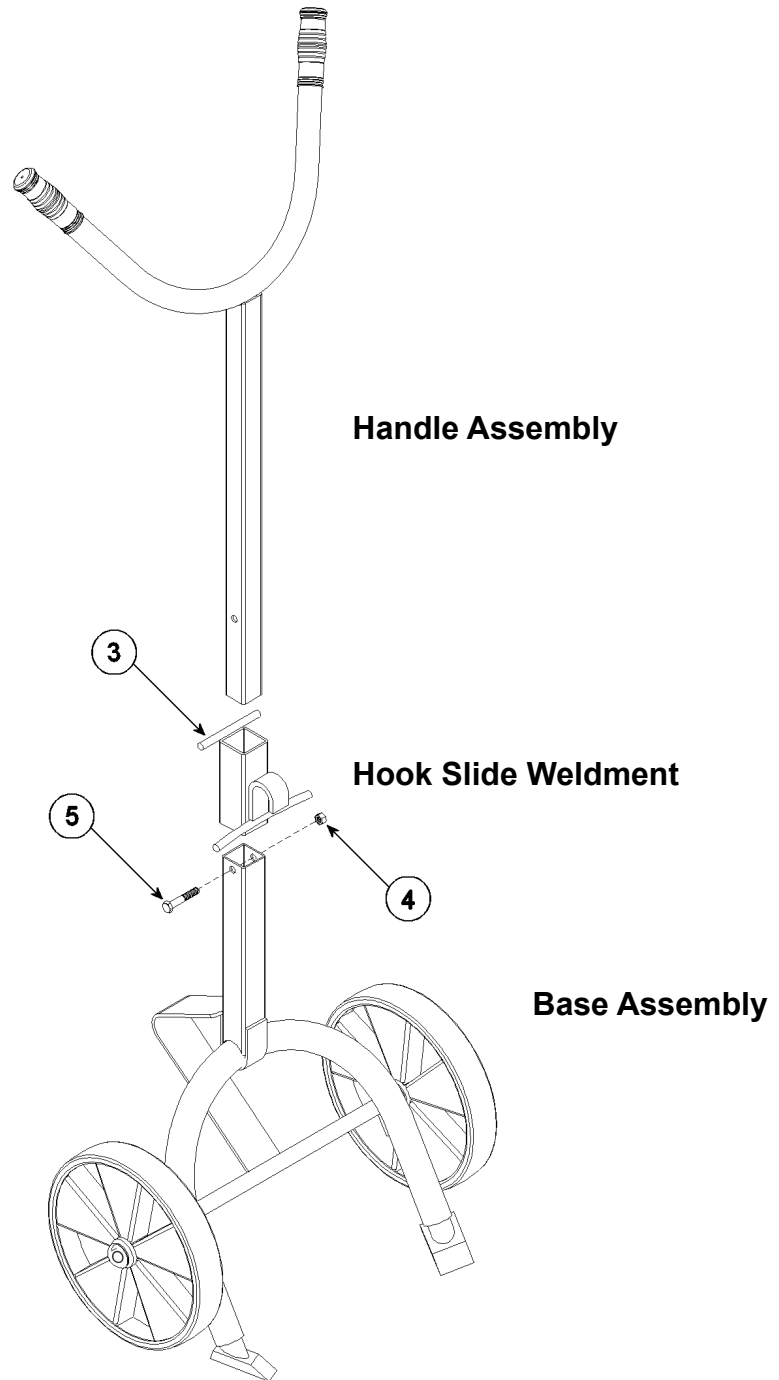

Model 152 shown



WARNING: This product can expose you to chemicals including barium sulfate, cobalt, titanium dioxide, and 2-methylimidazole, which are known to the State of California to cause cancer, and bisphenol-A, which is known to the State of California to cause birth defects or other reproductive harm. For more information go to www.P65Warnings.ca.gov

Parts List and Diagram for Models 152 and 153 Drum Hand Trucks Manufactured 03/2018 to _____

For replacement parts, please contact your Morse dealer.

When ordering parts, please specify:

- Part number and description
- Model number

Morse Model 152			
ITEM	QTY	PART #	DESCRIPTION
1	2	83-P	GRIP, HANDLE, 1-1/4 X 4-1/2
2	1	3970-P	HANDLE WELD, 152, 153, 155
3	1	1947-P	HOOK SLIDE WELD, 152
4	1	1169-P	NUT, 3/8-16 REV HEX LOCK
5	1	82-P	HHCS, 3/8-16 X 2-1/4 GR2
6	1	3971-P	BASE WELD, 152, 153
8 *	2	702-P	WHEEL, RUBBER, 10", 7/8" BORE
9 *	4	1850-P	COLLAR, 7/8" ID, 201B

Morse Model 153			
ITEM	QTY	PART #	DESCRIPTION
1	2	83-P	GRIP, HANDLE, 1-1/4 X 4-1/2
2	1	3970-P	HANDLE WELD, 152, 153, 155
3	1	1947-P	HOOK SLIDE WELD, 152
4	1	1169-P	NUT, 3/8-16 REV HEX LOCK
5	1	82-P	HHCS, 3/8-16 X 2-1/4 GR2
6	1	3971-P	BASE WELD, 152, 153
8 *	2	701-P	WHEEL, MORTUF, 10", 7/8" BORE
9 *	4	1850-P	COLLAR, 7/8" ID, 201B

* Recommended spare parts.

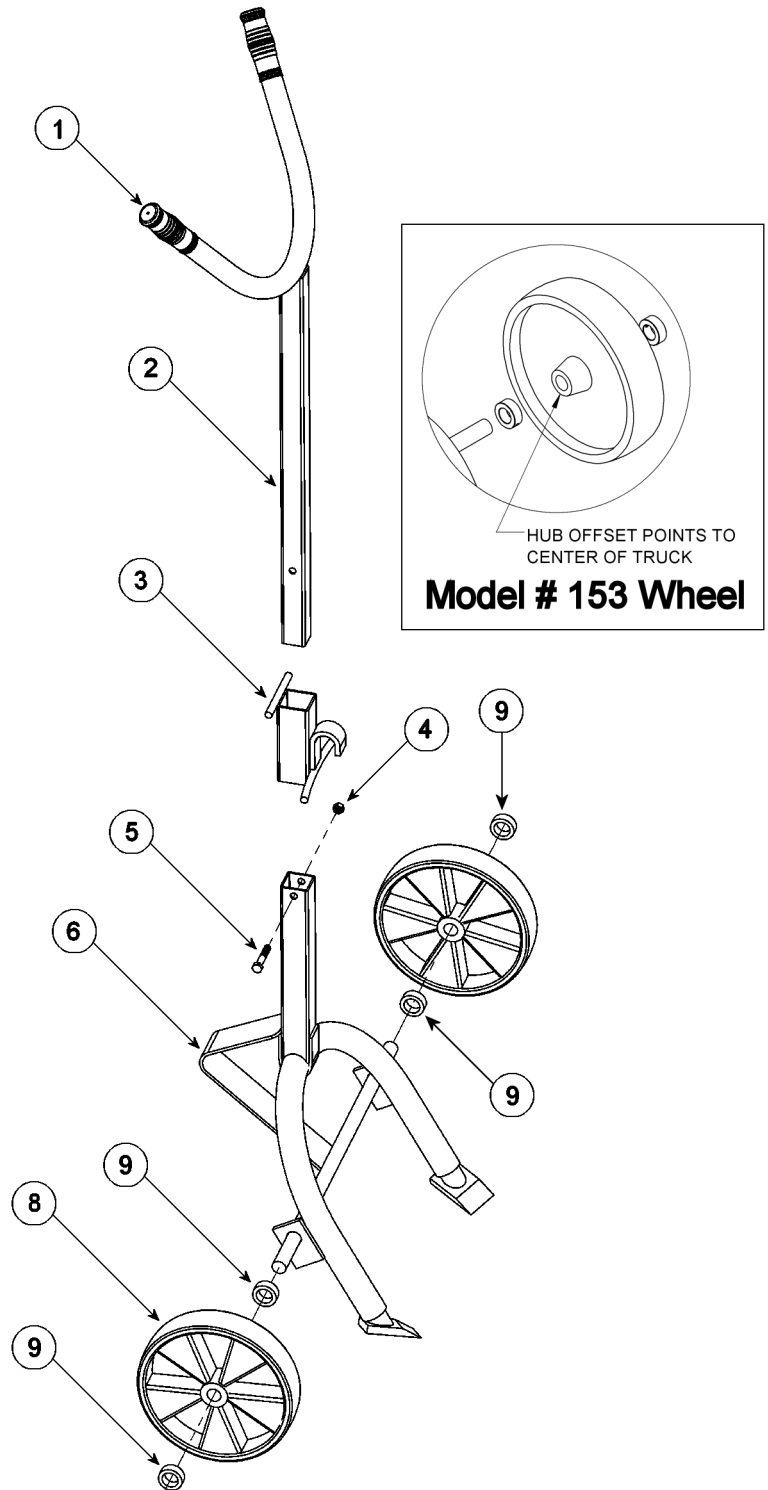

Model # 152 shown