

Job: _____

Item: _____

Quantity: _____

#99555 & 99640 - LADDER CARTS

- Easy-Load flat top shelves.
- Extended push handle = Shin Saver!
- Continuous grip handle for ascending and descending.
 - Extended reach bar on top.
- Extra wide steps are welded and bolted in place.
 - Fitted with non-slip tape for safety.
- Spring loaded, full contact ladder stops.
- All welded, tubular base frame.
- Caster mounts are welded to the frame.
- Custom sizes available.
- Lifetime Guarantee against rust and corrosion.

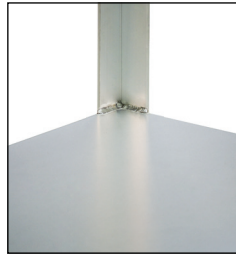

Easy-Load flat top shelves.



Extra wide steps are welded and bolted in place.

- Fitted with non-slip tape for safety.



MODEL #99555



MODEL #99640

This information is for general sales and engineering use only. New Age Industrial reserves the right to modify or make changes at any time without notice to materials and specifications.

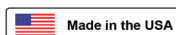

Distributed by:

Job: _____

Item: _____

Quantity: _____

#99555 & 99640 - LADDER CARTS

- Sheet parts are constructed of 5052-H32 Alloy aluminum.
- Extrusion parts are constructed of 6063-T5 Alloy aluminum.
- Ladder consists of 1.49" O.D. pipe, .153" wall uprights, 1" O.D. pipe, .125" handle and steps are formed out of .125" thick sheet.
- Cart uprights are formed of 3/16" sheet.
- Each shelf is constructed of 1-1/4" square tube, .07" wall covered with .08" sheet.
- Lifetime Guarantee against rust and corrosion.

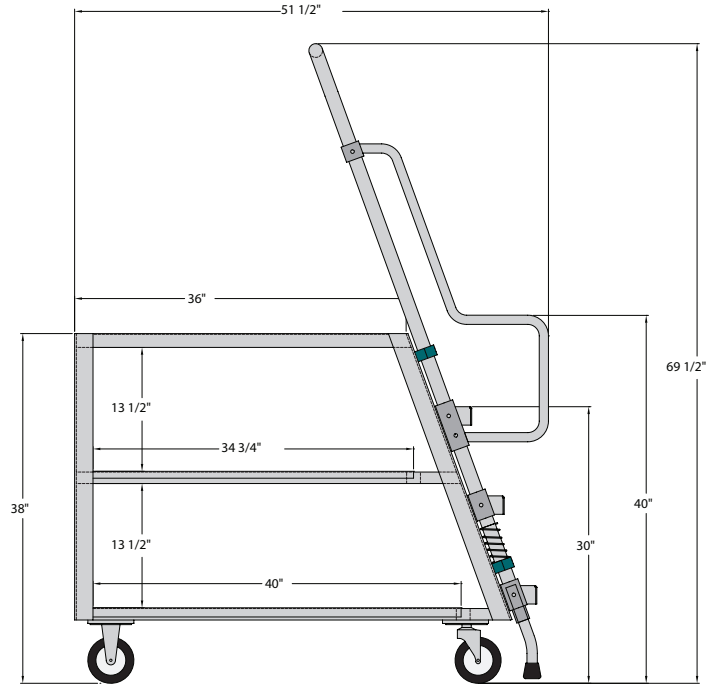

MODEL #99555

Model No	Size W-H-L	No. Of Shelves	Top Shelf Height	Shelf Spacing	Wt. Cap.	Ship Wt.
99640	22" x 69-1/2" x 51-1/2"	2	38"	21-3/4"	800#	113#
99555	22" x 69-1/2" x 51-1/2"	3	38"	13-1/2"	800#	120#

Four 5" platform type casters, two swivel (#C461) two rigid (#C463).

This information is for general sales and engineering use only. New Age Industrial reserves the right to modify or make changes at any time without notice to materials and specifications.



Distributed by: