

Job: _____

Item: _____

Quantity: _____

Low Boy Stock Cart

These carts are specially designed for transporting heavy loads from the backroom to the floor. Rounded front helps protect walls and displays.

- Framework is constructed out of 1½" x 1½" x .070" wall tubing.
- Handle is constructed out of 1½" diameter pipe.
- Model #1183 comes equipped with four 5" platform type swivel casters and two 6" platform type rigid casters.
- Model #1184 comes equipped with four 5" platform type casters, two swivel and two rigid.
- Five-Year Guarantee against material defects and workmanship.
- Lifetime Guarantee against rust and corrosion.
- NSF Certified.

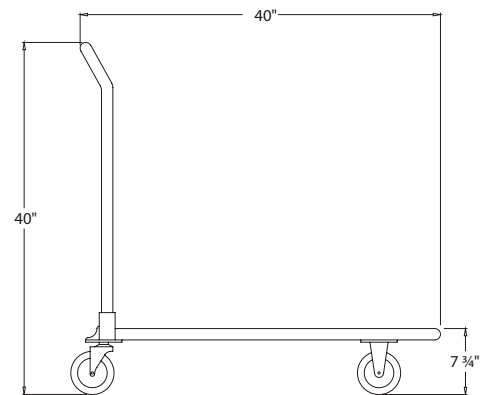
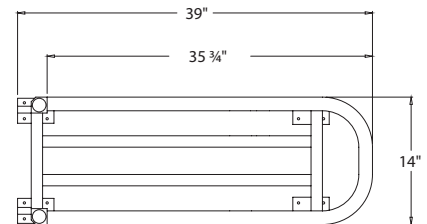

Model No.	Size W-H-L	Weight Capacity	Deck Height	No. Casters	Ship Lbs.
1183	16" x 41" x 54"	1000#	9½"	6	40.5
1184	14" x 40" x 39"	1000#	7¾"	4	23

Model #1183: four 5" swivel (#C450) two 6" rigid (#C518) platform type casters.

Model #1184: two 5" swivel (#C450) two rigid (#C460) platform type casters.

EACH UNIT HAS A REMOVABLE HANDLE.

This information is for general sales and engineering use only. New Age Industrial reserves the right to modify or make changes at any time without notice to materials and specifications.

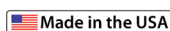

Distributed by: