

JOB:
ITEM:
QTY:

POLY BOX/SHEET PAN COMBINATION RACK

APPLICATION:

These racks are specially designed to hold both a sheet pan and a poly box. These racks serve the same purpose as two racks, in one. Save money and just buy one rack for two jobs.

MATERIAL:

Framework is constructed out of 1"x1"x.070" wall tubing. Angle runners are constructed out of 5/8"x15/16"x.125" wall angle.

CASTERS:

These racks come equipped with four 5" platform type swivel casters, two with brake.

GUARANTEE:

These racks carry a **Lifetime Guarantee** against rust and corrosion and also carry a **Five-Year Guarantee** against workmanship and material defects.



Model #1486



Phone: 800-255-0104
Fax: 877-877-7687
www.newageindustrial.com
sales@newageindustrial.com

New Age Industrial reserves the right to modify or make changes at any time without notice to materials and specifications.

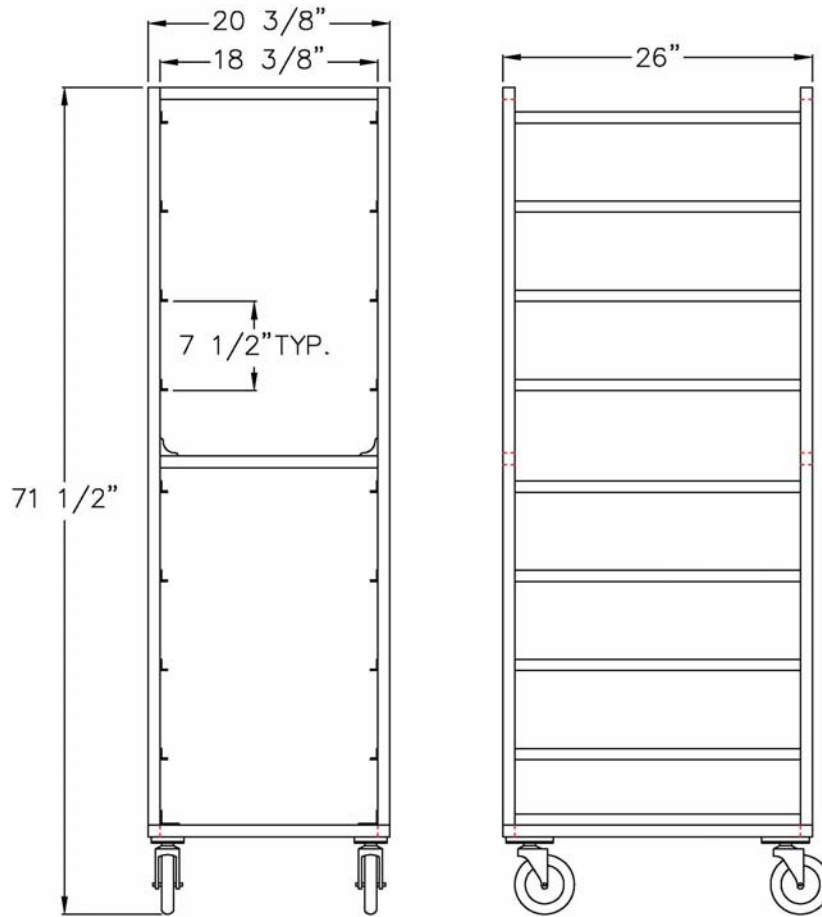

Model #1486

Model No.	Size-W	Size-H	Size-D	Pan Cap.	Runner Spacing
1482	20 3/8"	71 1/2"	26"	13	5"
1484	20 3/8"	71 1/2"	26"	17	3 1/2"
1486	20 3/8"	71 1/2"	26"	9	7 1/2"



Phone: 800-255-0104
 Fax: 877-877-7687
www.newageindustrial.com
sales@newageindustrial.com

New Age Industrial reserves the right to modify or make changes at any time without notice to materials and specifications.