

Job: _____

Item: _____

Quantity: _____

Modular Equipment Stand

Specifically Designed To Accommodate Counter-Top Cooking & Warming Equipment.

This all purpose stand is perfect for counter-top cooking as well as holding or serving equipment. Removable heavy-duty 12-gauge aluminum top and optional under shelf lift off for easy cleaning and are fully supported by the all welded, heavy-duty frame.

Marine edge provides easy cleaning and equipment stability. Adjustable posts allow for quick stabilization and easy leveling on stationary units while 5" stem type casters provide smooth transportation for mobile units.

- Top is 12 gauge aluminum sheet, with 4 one inch lips down and marine edge around perimeter.
- Uprights consists of extruded aluminum OD. pipe of 1 5/16" and a wall thickness of .150". with plastic end caps on each end.
- Optional casters consist of four 5" stem type heavy-duty swivel casters (#C440) with non marking wheel.
- Optional undershelf is 12 gauge aluminum sheet.
- Five-Year Guarantee against material defects and workmanship.
- Lifetime Guarantee against rust and corrosion.
- NSF Certified.



12448GSC



12436GSCUSR

This information is for general sales and engineering use only. New Age Industrial reserves the right to modify or make changes at any time without notice to materials and specifications.

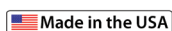

Distributed by:

Job: _____

Item: _____

Quantity: _____

Modular Equipment Stand

| Model No. | Size D-H-L | Ship Lbs. |
|---|-----------------|-----------|
| Stationary Units - Aluminum Top | | |
| 12436GS | 24" x 24" x 36" | 27.5 |
| 12448GS | 24" x 24" x 48" | 32 |
| 12460GS | 24" x 24" x 60" | 37 |
| 12472GS | 24" x 24" x 72" | 45 |
| 13036GS | 30" x 24" x 36" | 31 |
| 13048GS | 30" x 24" x 48" | 37 |
| 13060GS | 30" x 24" x 60" | 50 |
| 13072GS | 30" x 24" x 72" | 55 |
| Stationary Unit w/ Aluminum Top & Undershaft | | |
| 12436GSU | 24" x 24" x 36" | 37 |
| 12448GSU | 24" x 24" x 48" | 45 |
| 12460GSU | 24" x 24" x 60" | 51.5 |
| 12472GSU | 24" x 24" x 72" | 55 |
| 13036GSU | 30" x 24" x 36" | 43 |
| 13048GSU | 30" x 24" x 48" | 47 |
| 13060GSU | 30" x 24" x 60" | 62 |
| 13072GSU | 30" x 24" x 72" | 66 |
| Mobile Unit - Aluminum Top | | |
| 12436GSC | 24" x 24" x 36" | 38 |
| 12448GSC | 24" x 24" x 48" | 40 |
| 12460GSC | 24" x 24" x 60" | 47 |
| 12472GSC | 24" x 24" x 72" | 52 |
| 13036GSC | 30" x 24" x 36" | 41 |
| 13048GSC | 30" x 24" x 48" | 50 |
| 13060GSC | 30" x 24" x 60" | 52 |
| 13072GSC | 30" x 24" x 72" | 59 |
| Four 5" Stem Casters (#C440). | | |
| Mobile Unit w/ Aluminum Top & Undershaft | | |
| 12436GSCU | 24" x 24" x 36" | 44 |
| 12448GSCU | 24" x 24" x 48" | 51 |
| 12460GSCU | 24" x 24" x 60" | 57 |
| 12472GSCU | 24" x 24" x 72" | 70 |
| 13036GSCU | 30" x 24" x 36" | 51 |
| 13048GSCU | 30" x 24" x 48" | 57 |
| 13060GSCU | 30" x 24" x 60" | 71 |
| 13072GSCU | 30" x 24" x 72" | 82 |

Four 5" Stem Casters (#C440).
Weight Capacity = 1000 lbs.

Options:

Sandwich Rail - Add "SR" suffix to model #.

Note: Must use same length sandwich rail as Equipment Stand.

Other options available - Contact factory for quote.

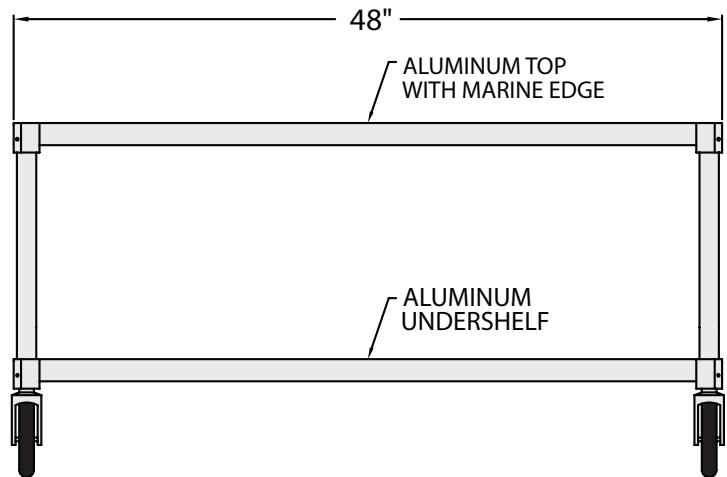
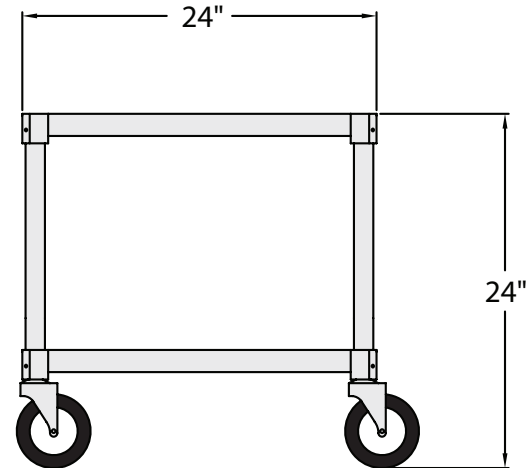

12448GSCU

This information is for general sales and engineering use only. New Age Industrial reserves the right to modify or make changes at any time without notice to materials and specifications.

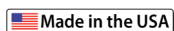

Distributed by: