

ESG GATES
(OPEN POSITION)

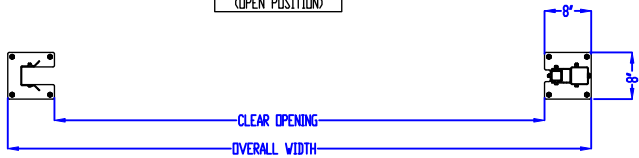

ESG GATES WITH TOE BOARD KIT
(OPEN POSITION)

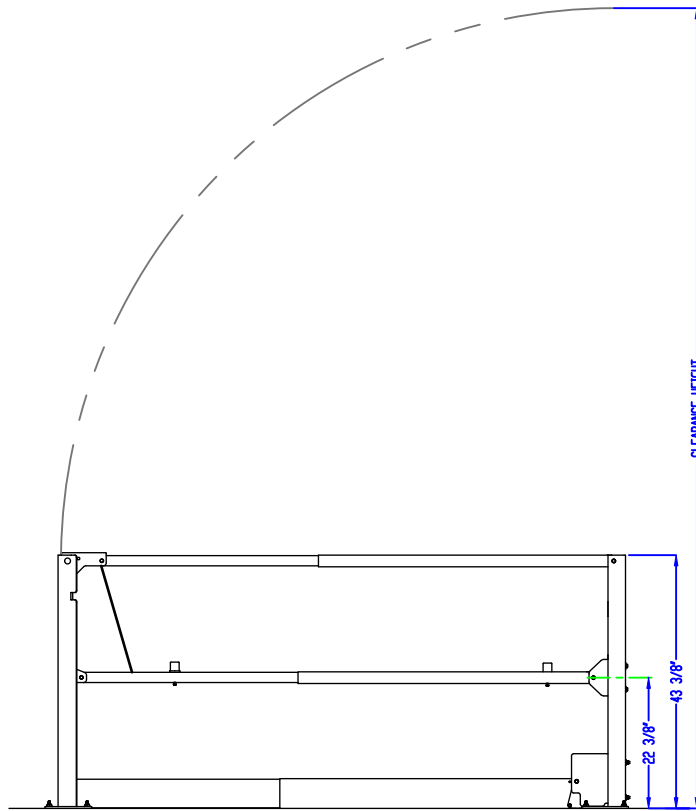
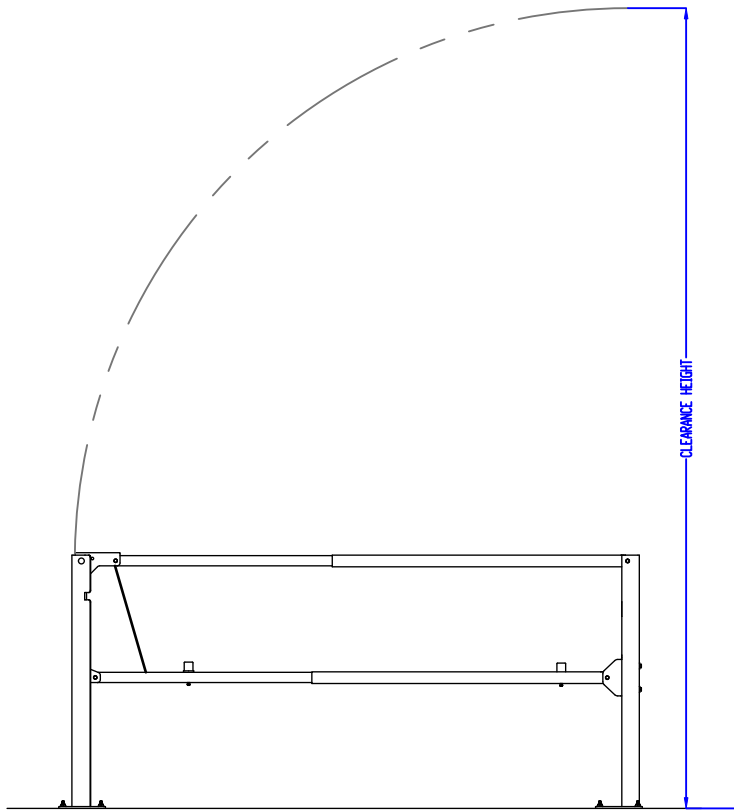
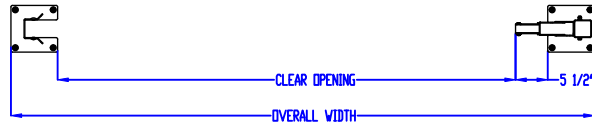

ESG SIZE REFERENCE CHART

MODEL	CLEAR OPENING	CLEARANCE HEIGHT	OVERALL WIDTH
ESG-60-PCY	84	95.5	100
	54	101.5	70
	60	107.5	76
	66	113.5	82
	72	119.5	88
ESG-60-PCY w/TOE BOARD	78	125.5	94
	42.5	95.5	58.5
	48.5	101.5	64.5
	54.5	107.5	70.5
	60.5	113.5	76.5
ESG-96-PCY	66.5	119.5	82.5
	72.5	125.5	88.5
	84	131.5	100
ESG-96-PCY w/TOE BOARD	96	153.5	112
	108	164.5	124
	78.5	131.5	94.5
ESG-120-PCY	90.5	153.5	106.5
	102.5	164.5	118.5
	108	164.5	124
ESG-144-PCY	120	176.5	136
	132	188.5	148
	132	188.5	148
ESG-144-PCY	144	200.5	160
	156	212.5	172

PROPRIETARY AND CONFIDENTIAL DRAWINGS ARE EXCLUSIVE PROPERTY OF PS INDUSTRIES INCORPORATED AND CANNOT BE USED IN WHOLE OR PART WITHOUT WRITTEN CONSENT © 2021 PS INDUSTRIES INCORPORATED ALL RIGHTS RESERVED

FINISH:

PRODUCT DESCRIPTION:

WDR:

SN:

CHECKED: /

SHIP TO:

SOLD TO:

PROJECT NAME:

SD #:

DWG STATUS:

FOR REFERENCE ONLY

ESTIMATED WEIGHT:

DWG #:

DWG BY:

PART #:

DATE: 2/25/2021

SCALE: NTS

SHEET # 1

REV: A



1150 48th St S
GRAND FORKS, ND 58201
PH 701-746-4519
FAX 701-746-8340