

22"

STAINLESS STEEL HIGH VELOCITY FAN

As shown:
Yoke Mount Standard

Mounting Options



CW-Column Wall Mount

Shipping Weights: 91 lbs/41 kg

SIZE	CFM	HP	FAN DIMENSIONS			DISTANCE AIR THROW	SHIPPING WEIGHT
			W	D	I.D.		
22"	5570	1/2	29"	16"	22 1/2"	100' / 30m	69 lbs/31 kg

Propeller: 20.75 " Diameter, 3 Blade GalvAlum (19 Degree)

Fan Inlet/Outlet: Stainless 16 Gauge Spun Steel

Finger Guards: Stainless
OSHA STANDARD Steel Mesh

RPM: 1725

Decible: 76.5 dba

Enclosure: TEAO Standard/Washdown Available

Frame: 56

Ambient Temperature: 40C

Duty Cycle: Continuous

Power Cord (115V Only): 12' Length

Coverage: 3600 Sq.Ft. Max

Voltage	Motor Amps	Running Amps
115V/208-230V*	6.0/2.9-3.0	5.4/2.6-2.7
208-230/460V	2.3-2.4/1.2	2.0-2.1/1.1
277V	3.6	3.2

* Standard

22" High Velocity Fan Air Flow Pattern

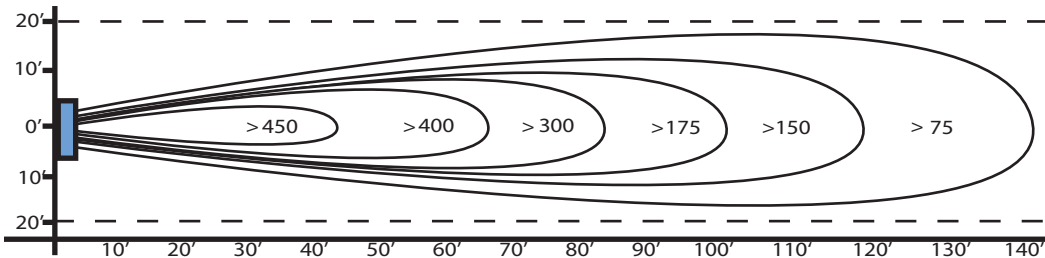

Above velocities shown in feet per minute.



10/12/09

Note: Due to continual product improvement, items are subject to change without notice.

Patterson Fan Company, Inc
Blythewood, SC 29016
www.pattersonfan.com
800.768.3985



STAINLESS STEEL MOUNTS

YM Yoke Mount

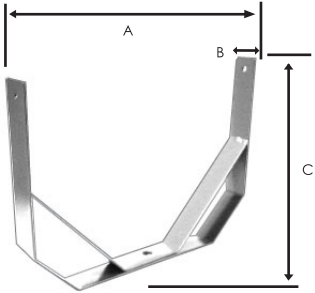

SIZES	MOUNT DIMENSIONS			SHIPPING WEIGHT
	A	B	C	
YM-22"	24"	2"	18"	15 lbs/7 kg

CW Column Wall Mount

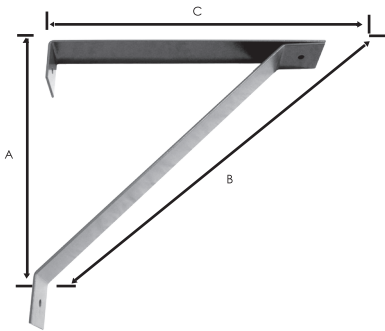

SIZES	MOUNT DIMENSIONS			SHIPPING WEIGHT
	A	B	C	
All Sizes: 14" - 30"	27"	38"	27"	22 lbs/10 kg

Contact your sales representative for available options.

Note: Due to continual product improvement, items are subject to change without notice.

Patterson Fan Company, Inc
1120 Northpoint Blvd. • Blythewood, SC 29016

www.pattersonfan.com
800.768.3985