

RivetRite®

Universal Shelf Framing System



www.pencoproducts.com



RivetRite

Defined

RivetRite Universal Shelf Framing System

We call RivetRite the Universal Shelf Framing System because so many storage requirements can be met with only a few simple components. RivetRite is engineered to provide safe, economical storage of virtually any type of hand-loaded material. Structural integrity is ensured by a rigid boltless connection between beams and posts.

RivetRite offers the following to help solve your storage problems:

- Economical — your shelving dollar goes a long way
- Easy assembly without special tools — all you need is a rubber mallet to assemble most units
- Access to contents from all four sides — no braces to get in the way
- Shelves adjustable on 1-1/2" centers — allows you to custom design unit to fit your load size
- Finished in durable powder coat enamel — baked on for permanence. The standard color is 723 Light Putty, however it is available in any of Penco's shelving colors at no additional cost
- A variety of beams to accommodate a wide range of loads — you buy the capacity you need



Contents

| | |
|--------------------------------------|----|
| Building Your RivetRite® Units | 3 |
| Single Rivet High Density Units..... | 4 |
| Double Rivet Storage Units..... | 6 |
| Record Storage Shelving..... | 8 |
| Inventory Systems..... | 10 |
| RivetRite® Two-Level Storage..... | 12 |
| Two-Level Accessories..... | 13 |
| RivetRite® Components..... | 14 |
| Technical Information | 19 |
| Color Chart..... | 20 |
| QuickShip Program | 21 |



Building Your RivetRite® Units

Single Rivet Unit

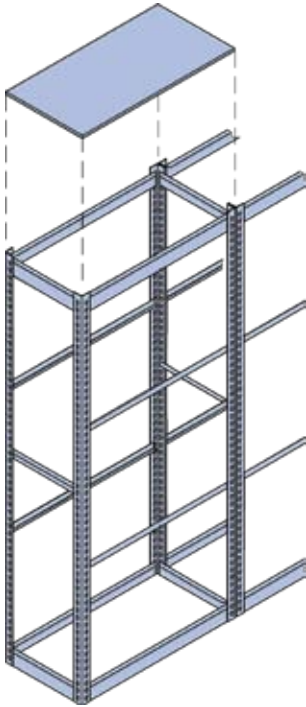

Double Rivet Unit

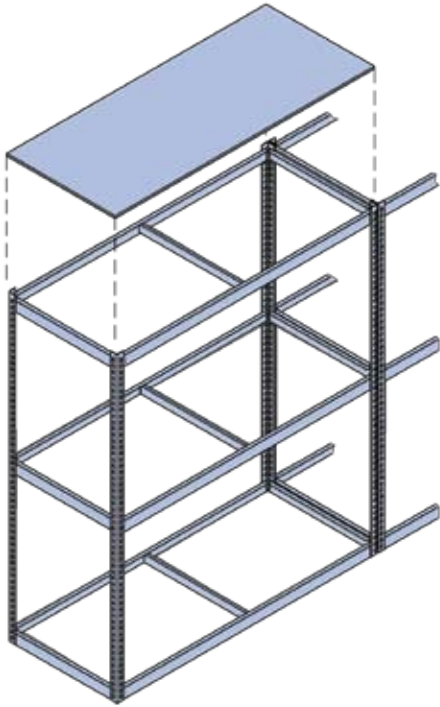

Starter Add-On



Starter Add-On



Starter and Add-On units are combined to form economical rows of shelving. Each Add-On unit includes a pair of tee posts which are used in common between units. This reduces assembly time and the number of parts required. Begin each row with two angle posts from the starter unit and join the desired number of add-on units to complete the row. Finish the last unit with a pair of angle posts from the starter unit.

Six Steps for Selecting Your RivetRite® Units

- 1.** Review the catalog and decide what type of unit will meet your requirement.
- 2.** Determine the shelf size desired and select the capacity needed. Note the capacity shown is for the steel structure only.
- 3.** Next determine the type of shelf deck material and calculate the quantity. Note that none of the unit catalog numbers include decking. Particle Board decking available from Penco is unfinished and natural in color.
- 4.** The standard color for all steel parts is 723 Light Putty, however RivetRite is available in all Penco shelving colors at no additional cost.
- 5.** All starter units are furnished with four Angle Posts. Add-on units have two intermediate Tee Posts. When assembling units, always put the Angle Posts at the extreme ends of the shelving row. Note that shelving growth will always occur; see Growth Chart on page 20.
- 6.** When ordering piece parts from the Component Parts pages of the catalog, contact your Penco representative for guidance on piece part capacities and product application to insure structural integrity.

* All dimensions in the following tables are in inches and are subject to change without notice.

Single Rivet High Density Units

Penco Single Rivet Beam High Density shelving is designed to provide for maximum vertical clearance between shelves. Access to stored item from all sides is possible because side and back cross braces are not necessary for stability. Add-on units assemble quickly without special tools by using a common tee post between units. Finished with an attractive baked powder coat finish.



To Order:
Page 5 for Units
Page 18 for Components

Deck material must be ordered separately.



Single Rivet Sizes and Dimensions

| Single Rivet High Density Units (84" High) | | | | | | |
|--|-------------|-----------------|------------------|------------------|------------------|------------------|
| Unit Width | Shelf Depth | Shelf Capacity* | 5 Shelf Cat. No. | 6 Shelf Cat. No. | 7 Shelf Cat. No. | 8 Shelf Cat. No. |
| 36" Starter Units | 12" | 350 | 461315 | 461316 | 461317 | 461318 |
| | 18" | 350 | 461325 | 461326 | 461327 | 461328 |
| | 24" | 350 | 461335 | 461336 | 461337 | 461338 |
| | 36" | 350 | 461345 | 461346 | 461347 | 461348 |
| 36" Add-On Units | 12" | 350 | 462355 | 462356 | 462357 | 462358 |
| | 18" | 350 | 462365 | 462366 | 462367 | 462368 |
| | 24" | 350 | 462375 | 462376 | 462377 | 462378 |
| | 36" | 350 | 462385 | 462386 | 462387 | 462388 |
| 48" Starter Units | 12" | 250 | 461415 | 461416 | 461417 | 461418 |
| | 18" | 250 | 461425 | 461426 | 461427 | 461428 |
| | 24" | 250 | 461435 | 461436 | 461437 | 461438 |
| | 36" | 250 | 461445 | 461446 | 461447 | 461448 |
| 48" Add-On Units | 12" | 250 | 462455 | 462456 | 462457 | 462458 |
| | 18" | 250 | 462465 | 462466 | 462467 | 462468 |
| | 24" | 250 | 462475 | 462476 | 462477 | 462478 |
| | 36" | 250 | 462485 | 462486 | 462487 | 462488 |



Starter



Add-On

Single Rivet High Density Units

Single Rivet High Density shelving uses single rivet beams on intermediate levels, and double rivet beams at the top and bottom for rigidity. For units up to 48" wide.

Starter and add-on units are combined to form economical rows of shelving. Each add-on unit includes a pair of tee posts which are used in common between units. This reduces assembly time and the number of parts required. Begin each row with two angle posts from the starter unit and join the desired number of add-on units to complete the row. Finish the last unit with a pair of angle posts from the starter unit.

All intermediate shelves on units that exceed 24" deep utilize single rivet beams for front to back shelf deck support.

Units 12", 18" and 24" deep include one pair of single rivet beams for intermediate use front to back.

- High Density Shelf Beams provide maximum space between shelf levels
- Common tee posts between starter and add-on unit
- Shelf levels adjust on 1-1/2" centers
- Fast easy assembly
- No special tools needed
- Optional heavy duty single rivet shelf beams available for added capacity



Double Rivet Bulky Storage Units

Penco RivetRite bulky shelving is designed to provide an economical solution for the storage of retail, wholesale or industrial goods. Installation can be done without special tools in a minimum amount of time. All steel parts are finished in attractive baked powder coat enamel.

Starter and add-on units are combined to form economical rows of shelving. Each add-on unit includes a pair of tee posts which are used in common between units. This reduces assembly time and the number of parts required. Begin each row with two angle posts from the starter unit and join the desired number of add-on units to complete the row. Finish the last unit with a pair of angle posts from the starter unit.

- 48" to 96" wide beams
- Access to stored items from all sides
- Choice of beam capacity to meet your storage requirement
- Easy assembly without special tools
- Units available in 84" and 120" heights



To Order:
Page 7 for Units
Page 18 for Components

Deck material must be ordered separately.



Standard Beam



Heavy Duty Beam



Channel Beam



Double Rivet Sizes and Dimensions

| Double Rivet Bulky Storage Units (With 4 Shelves - 84" High) | | | | | | | | |
|--|------------------|-------------|------------------------|------------------|-----------------|---------------------|------------------|-----------------|
| | | | WITHOUT Center Support | | | WITH Center Support | | |
| Unit Width | Beam Type | Shelf Depth | Shelf Capacity* | Starter Cat. No. | Add-On Cat. No. | Shelf Capacity* | Starter Cat. No. | Add-On Cat. No. |
| 48" Wide Units | Heavy Duty Angle | 18" | 750 | 46001H | 46006H | 1400 | 46W01H | 46W06H |
| | Heavy Duty Angle | 24" | 750 | 46002H | 46007H | 1400 | 46W02H | 46W07H |
| | Heavy Duty Angle | 30" | 750 | 46003H | 46008H | 1310 | 46W03H | 46W08H |
| | Heavy Duty Angle | 36" | 750 | 46004H | 46009H | 1220 | 46W04H | 46W09H |
| | Heavy Duty Angle | 48" | 750 | 46005H | 46010H | 1125 | 46W05H | 46W10H |
| 60" Wide Units | Heavy Duty Angle | 18" | 600 | 46011H | 46016H | 1200 | 46W11H | 46W16H |
| | Heavy Duty Angle | 24" | 600 | 46012H | 46017H | 1200 | 46W12H | 46W17H |
| | Heavy Duty Angle | 30" | 600 | 46013H | 46018H | 1200 | 46W13H | 46W18H |
| | Heavy Duty Angle | 36" | 600 | 46014H | 46019H | 1200 | 46W14H | 46W19H |
| | Heavy Duty Angle | 48" | 600 | 46015H | 46020H | 1200 | 46W15H | 46W20H |
| | Channel | 18" | - | - | - | 2240 (1) | 46W01C | 46W06C |
| | Channel | 24" | - | - | - | 2240 (1) | 46W02C | 46W07C |
| | Channel | 30" | - | - | - | 2240 (1) | 46W03C | 46W08C |
| | Channel | 36" | - | - | - | 2240 (1) | 46W04C | 46W09C |
| | Channel | 48" | - | - | - | 2240 (1) | 46W05C | 46W10C |
| 72" Wide Units | Heavy Duty Angle | 18" | 500 | 46021H | 46026H | 1000 | 46W21H | 46W26H |
| | Heavy Duty Angle | 24" | 500 | 46022H | 46027H | 1000 | 46W22H | 46W27H |
| | Heavy Duty Angle | 30" | 500 | 46023H | 46028H | 1000 | 46W23H | 46W28H |
| | Heavy Duty Angle | 36" | 500 | 46024H | 46029H | 1000 | 46W24H | 46W29H |
| | Heavy Duty Angle | 48" | 500 | 46025H | 46030H | 1000 | 46W25H | 46W30H |
| | Channel | 18" | - | - | - | 1850 | 46W11C | 46W16C |
| | Channel | 24" | - | - | - | 1850 | 46W12C | 46W17C |
| | Channel | 30" | - | - | - | 1850 | 46W13C | 46W18C |
| | Channel | 36" | - | - | - | 1850 | 46W14C | 46W19C |
| | Channel | 48" | - | - | - | 1850 | 46W15C | 46W20C |
| 96" Wide Units | Heavy Duty Angle | 18" | - | - | - | 620 | 46W31H | 46W36H |
| | Heavy Duty Angle | 24" | - | - | - | 620 | 46W32H | 46W37H |
| | Heavy Duty Angle | 30" | - | - | - | 620 | 46W33H | 46W38H |
| | Heavy Duty Angle | 36" | - | - | - | 620 | 46W34H | 46W39H |
| | Heavy Duty Angle | 48" | - | - | - | 620 | 46W35H | 46W40H |
| | Channel | 18" | - | - | - | 1400 | 46W21C | 46W26C |
| | Channel | 24" | - | - | - | 1400 | 46W22C | 46W27C |
| | Channel | 30" | - | - | - | 1400 | 46W23C | 46W28C |
| | Channel | 36" | - | - | - | 1400 | 46W24C | 46W29C |
| | Channel | 48" | - | - | - | 1400 | 46W25C | 46W30C |

| Double Rivet Bulky Storage Units (With 5 Shelves - 120" High) | | | | | | | | |
|---|------------------|-------------|------------------------|------------------|-----------------|---------------------|------------------|-----------------|
| | | | WITHOUT Center Support | | | WITH Center Support | | |
| Unit Width | Beam Type | Shelf Depth | Shelf Capacity* | Starter Cat. No. | Add-On Cat. No. | Shelf Capacity* | Starter Cat. No. | Add-On Cat. No. |
| 72" Wide Units | Heavy Duty Angle | 30" | 500 | 46041H | 46044H | 1000 | 46W41H | 46W44H |
| | Heavy Duty Angle | 36" | 500 | 46042H | 46045H | 1000 | 46W42H | 46W45H |
| | Heavy Duty Angle | 48" | 500 | 46043H | 46046H | 1000 | 46W43H | 46W46H |
| | Channel | 30" | - | - | - | 1850 (2) | 46W31C | 46W34C |
| | Channel | 36" | - | - | - | 1850 (2) | 46W32C | 46W35C |
| 96" Wide Units | Channel | 48" | - | - | - | 1850 (2) | 46W33C | 46W36C |
| | Heavy Duty Angle | 30" | - | - | - | 620 | 46W47H | 46W50H |
| | Heavy Duty Angle | 36" | - | - | - | 620 | 46W48H | 46W51H |
| | Heavy Duty Angle | 48" | - | - | - | 620 | 46W49H | 46W52H |
| | Channel | 30" | - | - | - | 1400 | 46W37C | 46W40C |
| 96" Wide Units | Channel | 36" | - | - | - | 1400 | 46W38C | 46W41C |
| | Channel | 48" | - | - | - | 1400 | 46W39C | 46W42C |

* Capacity shown are for the steel support beams, not the shelf deck material. For higher support beam capacity, see "RivetRite Coponents." Capacities are in pounds for evenly distributed loads.

All unit catalog numbers include metal framing only. Shelf deck material must be ordered separately.

All Double Rivet Bulky Storage Units with Channel Beams are furnished with Heavy Duty Double Rivet Angle Beams (left to right) at the bottom level.

(1) - Max. Average Shelf Load 2000# per shelf.

(2) - Max. Shelf Load 1490# per shelf.



Record Storage Shelving

RivetRite Record Storage Units will aid in records management by providing an organized solution to high density archive storage.

Two types of units are available; one that utilizes particle board decking to support the boxes, and an all steel unit with specially designed box supports. (Particle board must be ordered separately — see the table on page 11).

Fire insurance premium savings may be realized by using units with steel box supports. Check with your insurance carrier.

- Assembles without special tools
- Records can be retrieved from both sides
- Units can be added as needed
- Two shelf types available; particleboard and steel box supports

Add-on units utilize a common Tee Post between units to save time during assembly.



To Order:
Page 9 for Units
Page 18 for Components

Deck material must be ordered separately.



Record Storage Sizes and Dimensions

| Record Storage Units | | | | | | |
|----------------------|------------|-------------|----------------|---------------|------------------|-----------------|
| For Use With Decking | | | | | | |
| Unit Width | Unit Depth | Unit Height | No. of Shelves | No. of Boxes* | Starter Cat. No. | Add-On Cat. No. |
| 42" | 15" | 84" | 4 | 24 | 46601A | 46613A |
| 42" | 30" | 84" | 4 | 48 | 46602A | 46614A |
| 69" | 15" | 84" | 4 | 40 | 46603A | 46615A |
| 69" | 30" | 84" | 4 | 80 | 46604A | 46616A |
| 42" | 15" | 108" | 5 | 30 | 46605A | 46617A |
| 42" | 30" | 108" | 5 | 60 | 46606A | 46618A |
| 69" | 15" | 108" | 5 | 50 | 46607A | 46619A |
| 69" | 30" | 108" | 5 | 100 | 46608A | 46620A |
| 69" | 15" | 168" | 7 | 70 | 46609A | 46621A |
| 69" | 30" | 168" | 7 | 140 | 46610A | 46622A |
| 69" | 15" | 192" | 8 | 80 | 46611A | 46623A |
| 69" | 30" | 192" | 8 | 160 | 46612A | 46624A |
| With Box Supports | | | | | | |
| Unit Width | Unit Depth | Unit Height | No. of Shelves | No. of Boxes* | Starter Cat. No. | Add-On Cat. No. |
| 42" | 15" | 60" | 3 | 18 | 46701A | 46709A |
| 42" | 30" | 60" | 3 | 36 | 46702A | 46710A |
| 69" | 15" | 60" | 3 | 30 | 46703A | 46711A |
| 69" | 30" | 60" | 3 | 60 | 46704A | 46712A |
| 42" | 15" | 84" | 4 | 24 | 46705A | 46713A |
| 42" | 30" | 84" | 4 | 48 | 46706A | 46714A |
| 69" | 15" | 84" | 4 | 40 | 46707A | 46715A |
| 69" | 30" | 84" | 4 | 80 | 46708A | 46716A |

* All unit box capacities are based on a standard archive box size of approximately 12-1/2" wide x 16-1/2" deep x 10-1/2" high. 42" wide units hold 3 boxes across; 69" wide units hold 5 boxes across.



Record Storage Box Supports

Box Supports allow air to circulate around the entire box, helping to reduce moisture and musty smells. They align with holes pre-punched in the special double rivet beams and are secured with nylon button fasteners.

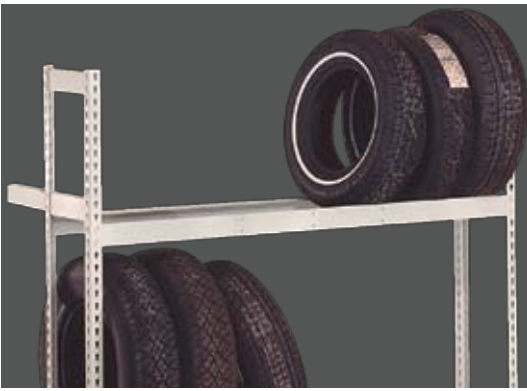

Inventory Systems

Tire Storage Rack

Penco RivetRite® Tire Racks provide for the neat organized storage of standard automobile or light truck tires. Specially designed beams with a 30° flange on the top securely cradle the tires. Available in Single-Row, (12" deep units with 9" Wall Ties) and Double-Row, (two 12" deep units separated by 18" Double Row Spacers). Unit depth shown includes wall ties/row spacers. Deeper units are available to accommodate larger SUV tires.

Hanging Tailpipe Rack

Designed specifically for the storage of automotive and light truck tailpipes. Assembles in minutes without special tools. Stored items are visible and easily accessible.



Inventory Cart

The Penco Inventory Cart transports supplies, orders, merchandise, tools or files from point to point with ease. The cart is easy to assemble and additional shelves can be quickly added. Shelves can be adjusted to fit a wide variety of load sizes, providing greater flexibility than traditional carts. The Penco Inventory Cart delivers the goods by reducing the cost of material handling.

Muffler Storage Unit

Uniform storage of various size mufflers is achieved through the use of RivetRite Muffler Storage Units. Particle board must be ordered separately.



Inventory Systems Sizes and Dimensions

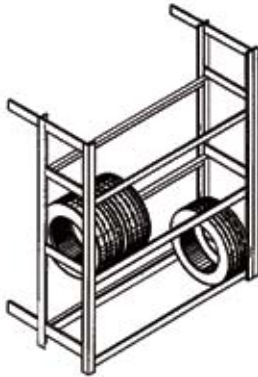

Single Row Starter



Single Row Add-On



Double Row Starter

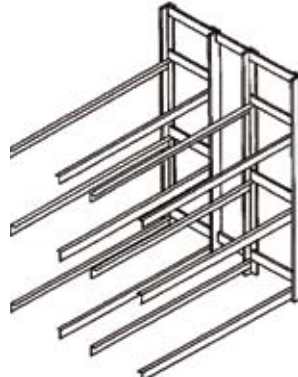

Double Row Add-On

| Tire Storage Rack | | | | | | |
|-------------------|------------|-------------|---------------|----------------|------------------|-----------------|
| Single Row | | | | | | |
| Unit Width | Unit Depth | Unit Height | No. of Levels | Tire Capacity* | Starter Cat. No. | Add-On Cat. No. |
| 60" | 21" | 84" | 3 | 24 | 46351T | 46451T |
| 60" | 21" | 120" | 4 | 32 | 46352T | 46452T |
| 60" | 21" | 144" | 5 | 40 | 46353T | 46453T |
| 60" | 21" | 192" | 6 | 48 | 46354T** | 46454T** |
| Double Row | | | | | | |
| Unit Width | Unit Depth | Unit Height | No. of Levels | Tire Capacity* | Starter Cat. No. | Add-On Cat. No. |
| 60" | 42" | 84" | 3 | 48 | 46355T | 46455T |
| 60" | 42" | 120" | 4 | 64 | 46356T | 46456T |
| 60" | 42" | 144" | 5 | 80 | 46357T | 46457T |
| 60" | 42" | 192" | 6 | 96 | 46358T** | 46458T** |

* Based on average passenger tire.

** Supplied with Heavy Duty Posts.

| Hanging Tailpipe Rack | | | |
|-----------------------|------------|-------------|----------|
| Clear Span | Unit Depth | Unit Height | Cat. No. |
| 48" | 18" | 120" | 46901P |
| 96" | 18" | 120" | 46902P |

| Inventory Cart | | | | | |
|-----------------------------|------------|-------------|---------------------|---------------|------------|
| 48" Cart with Three Shelves | | | | | |
| Unit Width | Unit Depth | Unit Height | Particle Board Deck | Melamine Deck | No Decking |
| 36" | 24" | 48" | 35076P | 35080P | 35095P |
| 48" | 24" | 48" | 35077P | 35081P | 35096P |
| 60" | 24" | 48" | 35078P | 35082P | 35097P |

| 60" Cart with Four Shelves | | | | | |
|----------------------------|------------|-------------|---------------------|---------------|------------|
| Unit Width | Unit Depth | Unit Height | Particle Board Deck | Melamine Deck | No Decking |
| 36" | 24" | 60" | 35074P | 35083P | 35092P |
| 48" | 24" | 60" | 35073P | 35084P | 35093P |
| 60" | 24" | 60" | 35075P | 35085P | 35094P |

| Additional Shelves | | | | | |
|--------------------|------------|-------------|---------------------|---------------|-----------|
| Unit Width | Unit Depth | Unit Height | Particle Board Deck | Melamine Deck | Sold Per |
| 36" | 24" | 1" | 35086P | 35089P | Shelf Kit |
| 48" | 24" | 1" | 35087P | 35090P | Shelf Kit |
| 60" | 24" | 3-5/8" | 35088P | 35091P | Shelf Kit |

Overall height of the 48" cart is 54" with base and wheels. Overall height of the 60" cart is 66" with base and wheels. All 36" and 48" wide carts use Single Rivet Beams on intermediate levels. All 60" wide carts use Double Rivet Beams on intermediate levels. Additional Shelf Kits consist of 4 Beams and Deck Material.

| Muffler Storage Unit | | | | |
|----------------------|------------|-------------|------------------|------------------|
| Unit Width | Unit Depth | Unit Height | Starter Cat. No. | Starter Cat. No. |
| 48" | 36" | 84" | 46801M | 46803M |
| 96" | 36" | 84" | 46802M | 46804M |

| Particle Board Decking | | | | | | | |
|------------------------|----------|-----------|----------|-----------|----------|-----------|----------|
| Size | Cat. No. | Size | Cat. No. | Size | Cat. No. | Size | Cat. No. |
| 36" x 12" | 94603 | 42" x 24" | 94616 | 60" x 18" | 94635 | 72" x 30" | 94657 |
| 36" x 15" | 94604 | 42" x 30" | 94617 | 60" x 24" | 94636 | 72" x 36" | 94658 |
| 36" x 18" | 94605 | 42" x 36" | 94618 | 60" x 30" | 94637 | 72" x 48" | 94659 |
| 36" x 24" | 94606 | 48" x 12" | 94623 | 60" x 36" | 94638 | 96" x 18" | 94665 |
| 36" x 30" | 94607 | 48" x 18" | 94625 | 60" x 48" | 94639 | 96" x 24" | 94666 |
| 36" x 36" | 94608 | 48" x 24" | 94626 | 69" x 15" | 94644 | 96" x 30" | 94667 |
| 42" x 12" | 94613 | 48" x 30" | 94627 | 69" x 30" | 94647 | 96" x 36" | 94668 |
| 42" x 15" | 94614 | 48" x 36" | 94628 | 72" x 18" | 94655 | 96" x 48" | 94669 |
| 42" x 18" | 94615 | 48" x 48" | 94629 | 72" x 24" | 94656 | | |



RivetRite® Two-Level Storage

The structural integrity of RivetRite lends itself to the construction of two-level storage facilities for applications where maximum utilization of overhead space is required. Expanding in an upward direction instead of outward keeps your personnel in closer proximity to each other and stored material, for more efficient operation.

Using standard components for support, economical units may be constructed with an open “deck-over” upper level, or additional shelving. In either case, savings are realized because:

- You virtually double the amount of storage space in a given floor area
- You utilize existing heat and air conditioning within the building

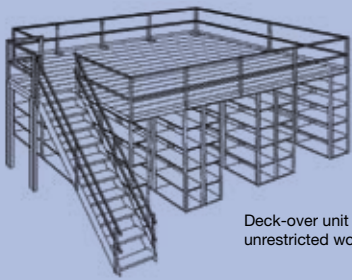

Deck-over unit provides an unrestricted work area.

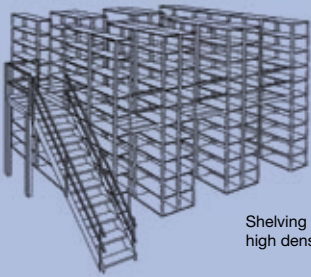

Shelving on both levels for high density storage.



Two-Level Accessories

Custom Stairs and Stair Structures

Stairs:

All applications involving stairs are reviewed individually and designed to meet or exceed local, state and federal codes in effect at the location where the stairs are to be installed.

Side frames are made from heavy duty MC10 structural steel. Handrails and inner handrails are welded in place, and all parts are finished with an attractive, durable powder coat finish.

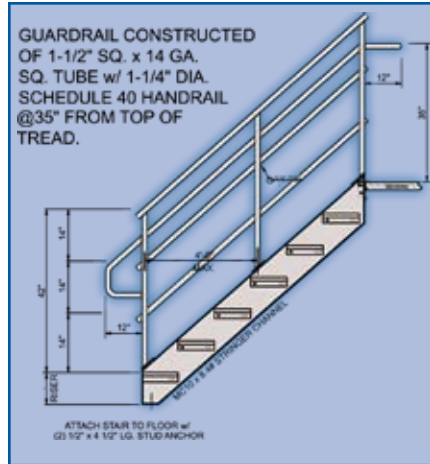
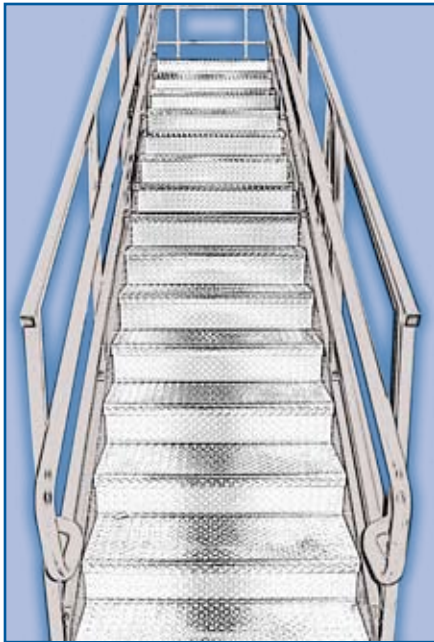

Landings:

Landings for stairs feature a heavy duty 1/8" diamond plate decking, handrail and kickplate on two sides and four column supports.

Two-column pedestal supported units are also available. Special sizes and baluster handrails is also available. All are finished with an attractive, durable powder coat finish.

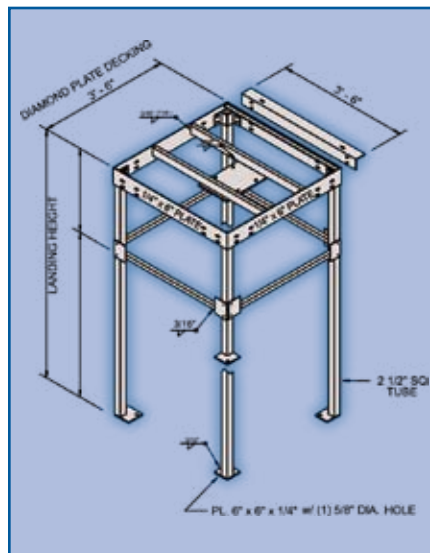

Handrail & Kickplate:

The Penco handrail is designed for two or three rails. It has welded tubular steel uprights and cross-rails with heavy gauge kickplate. All are finished with an attractive, durable powder coat finish.

Grating:

Penco Channel-Lock Safety Grating provides a non-corrosive and sure-footed ventilated work platform surface. Manufactured from 16 gauge high strength hot dip galvanized steel, the design allows it to interlock for added strength. (Ordering information on page 18)

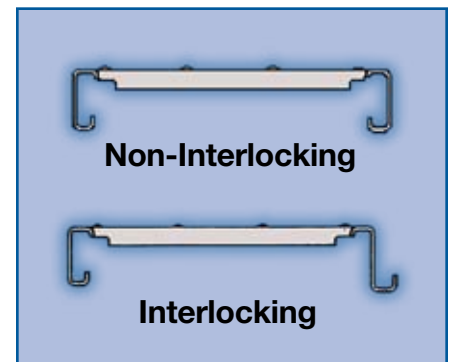

Other functional and popular work platform decking includes bar grating, roof deck and wood, or poly-coated non-skid surfaces. Your Penco representative can assist you in selecting the work surface that works best in your mult-level storage application.



RivetRite Components

Angle Post - Standard Duty:
1-1/2" x 1-1/2". Used as upright post for standard RivetRite units. (Ordering information on page 18)

Angle Post - Heavy Duty:
1-7/8" x 1-7/8". When maximum capacity and stability are essential, the heavy duty angle post is the proper choice. Ideally suited for two level shelving, storage deck and high rise shelving applications. (Ordering information on page 18)

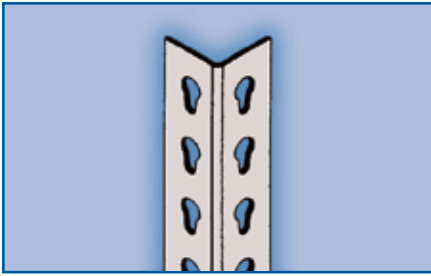

Tee Post - Standard Duty:
3" x 1-1/2". Included with standard duty add-on units to function as a common post between the starter unit and adjoining units. (Ordering information on page 18)

Tee Post - Heavy Duty:
3-3/4" x 1-7/8". Used in the same way as the standard tee, when increased load capacities are required. (Ordering information on page 18)

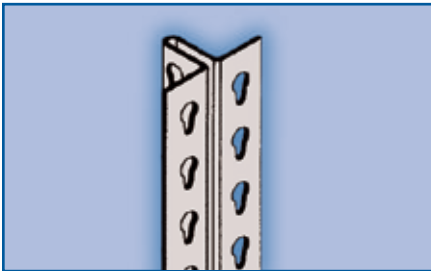

Single Rivet Shelf Beam - Standard Duty:
Primarily used as an intermediate shelf support when maximum vertical space between levels is needed. Furnished as standard on High Density Shelving units. (Ordering information on page 18)

Single Rivet Shelf Beam - Heavy Duty:
Manufactured to provide maximum capacity with very little loss of usable vertical space between shelves. (Ordering information on page 18)

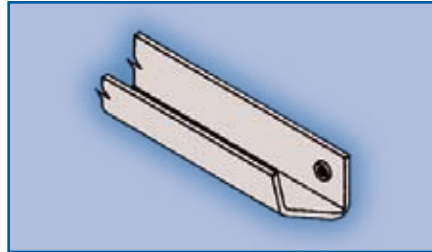

Double Rivet Channel Beam:
3" x 1". Channel is designed to provide maximum left to right stability and higher capacity than standard or heavy duty beams. Cannot be used at floor level! The top flange has holes for fastening decking. (Ordering information on page 18)

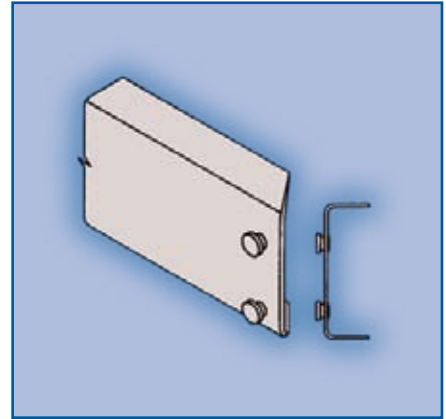

Double Rivet Angle Beam - Standard Duty:
Used to establish unit stability and to provide shelf support on all four sides. (Ordering information on page 18)

Double Rivet Angle Beam - Heavy Duty:
Provides stability and increased load capacity in the longer lengths. (Ordering information on page 18)

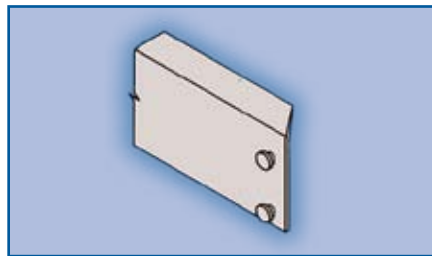

Center Support:
Used with double rivet beams to provide front-to-rear support for shelf deck and provides added stability to beams. (Ordering information on page 18)

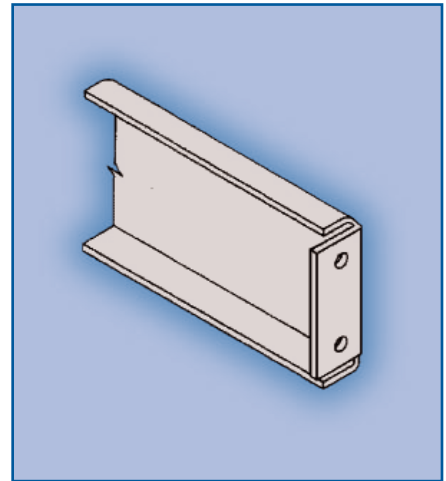

RivetRite Components

Double Rivet Zee Step Beams:

Reduced profile increases vertical clearance by 1-1/4" between shelf levels when used in place of Double Rivet Angle Beams. Protects decking edges. When used as the bottom shelf on Single Rivet Units, clear space between the bottom and first shelf is increased by 1-1/4". (Ordering information on page 18)

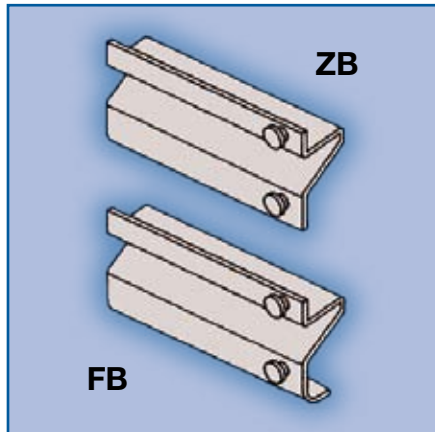

Decking Support for Zee Step Beam:

Used with Zee Step Beams for front to back decking support. (Ordering information on page 18)

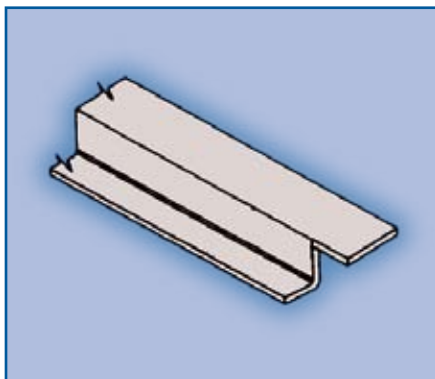

Double Rivet Low-Profile Beam:

Available in lengths up to 48", this beam has the smallest vertical profile of all double rivet beams. (Ordering information on page 18)

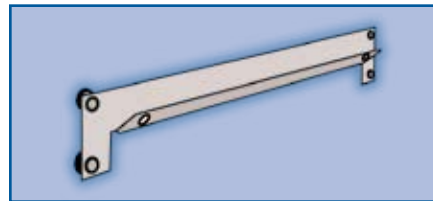

Anchors:

Used to secure posts to the floor (foot plates are used). Available in two lengths; the 2-1/4" length is sufficient for most usage, but areas of seismic activity higher than Zone 2A may require the 3-3/4" length. (Ordering information on page 18)



Post Splice:

1-3/8" x 1-3/8". Used to extend posts. Order one per angle post. Order two per tee post. Note: installs on the outside of the post. (Ordering information on page 18)



Tire Rack Beams:

2-3/4" high - For left to right shelf support of tires. 30 degree angle on supporting edge of tire rack beam. (Ordering information on page 18)

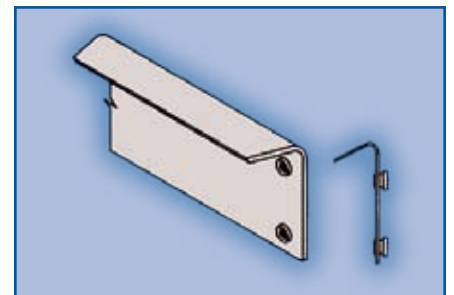

Wall Tie:

Used to secure units to wall and provide space between wall and attached units. Hardware is not included. (Ordering information on page 18)

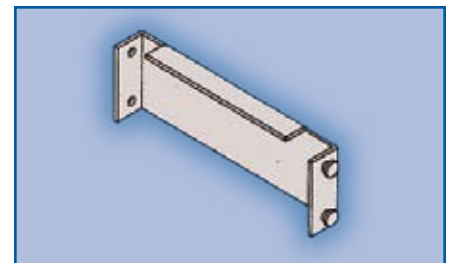

Double Row and Top Ties:

Designed to space back-to-back units and to top-tie rows across aisles for additional stability. (Ordering information on page 18)

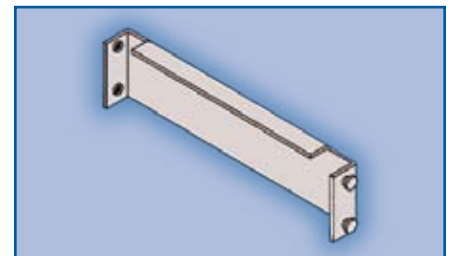

RivetRite Components

Flue Spacing Components:

To allow nominal 6" spacing between RivetRite units to satisfy NFPA (National Fire Protection Agency) safety recommendations.

The component pictured below is for use with RivetRite Angle Posts or to join tee post units back to back. (Catalog No. 46RT06, page 18)

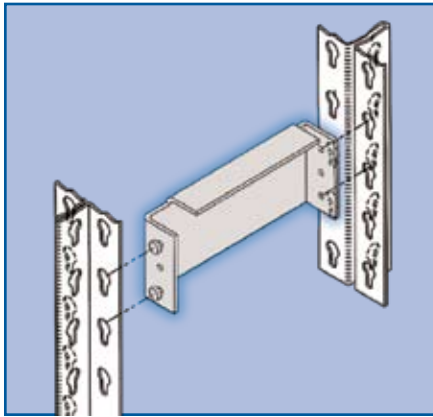

The component pictured below is for use with RivetRite Angle or Tee Posts positioned side by side. (Catalog No. 46AX153, page 18)

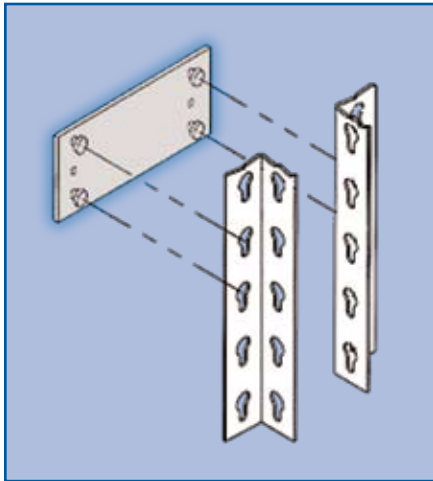

Foot Plate:

Includes Hardware. For use in anchoring angle and tee posts to the floor. NOTE: foot plate cannot be used if there is a double rivet channel beam at the lowest point. (Ordering information on page 18)

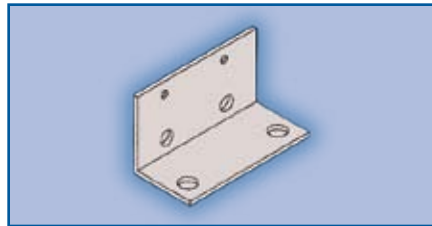

Record Storage Box Support:

Includes Hardware. Used in place of particle board to support boxes and maintain neat, organized storage. Supplied with nylon button fasteners. (Ordering information on page 18)

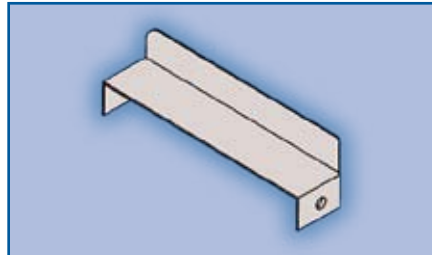

Hanger Bar:

1-1/4" x 1-1/4". For hanging items between double rivet beams. One or more may be used per level. (Ordering information on page 18)

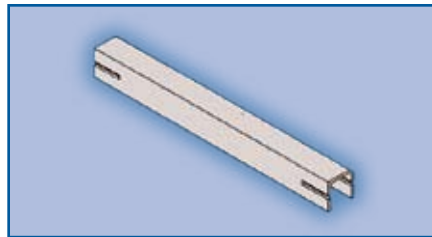

Beam Cleat:

An economical way to add on units. Not recommended for heavy loads. (Ordering information on page 18)

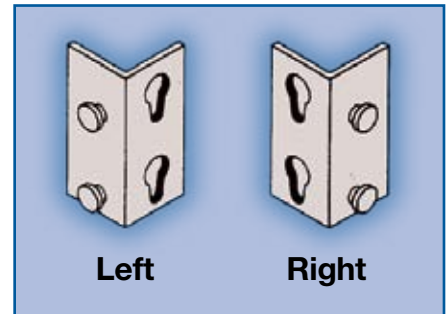

Slotted Angle Cleats:

For use where slotted angle pieces must be joined, such as special grating supports and top ties. (Ordering information on page 18)

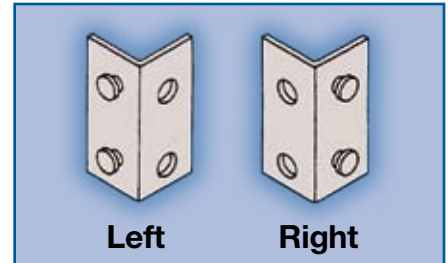

Down Aisle Grating Supports:

3-1/2". Attaches to unit front between rows to provide support for grating on two level shelving installations. (Ordering information on page 18)

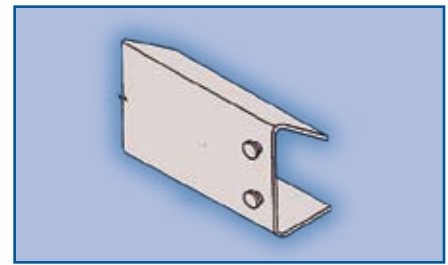

RivetRite Components

Shelving & Main Aisle Support:

To support decking across shelving or main aisle. Spacing between supports not to exceed 48". Includes Hardware to bolt to posts - formerly called Cross Aisle Support. (Ordering information on page 18)

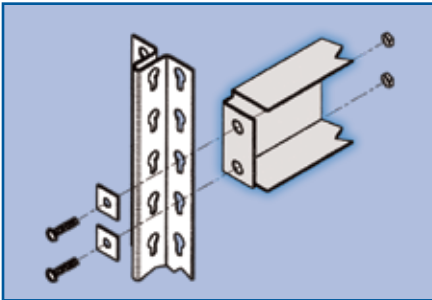

Tie Plate:

Used to join Angle Post units side by side to insure proper row alignment. (Ordering information on page 18)

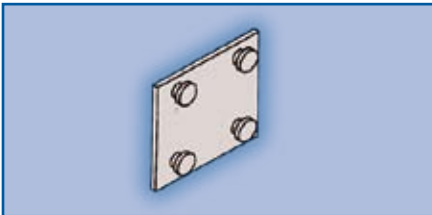

Deck-Over Grating Supports:

3-1/2". Provides sturdy and secure support for grating when decking over entire installation. (Ordering information on page 18)

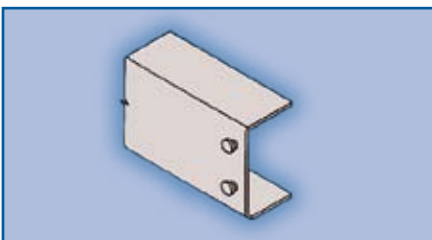

Grating Planks:

For use with Down Aisle Grating Supports. Penco Channel-Lock grating provides for sure-footed movement on aisles and upper level storage areas. Interlocking grating has male and female flanges that interlock with adjacent planks providing a continuous locked surface. Non-locking grating has planks butt against one another. Grating is secured to Down Aisle supports with self tapping screws. (Ordering information on page 18)

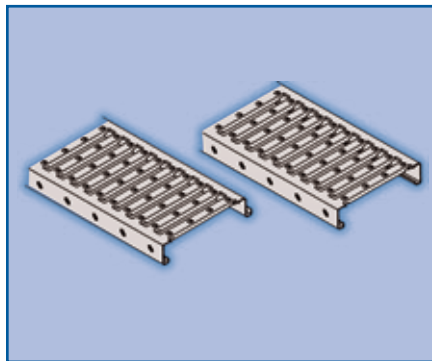

Grating Fillers:

3" Wide Galvanized Grating Fillers. (Ordering information on page 18)

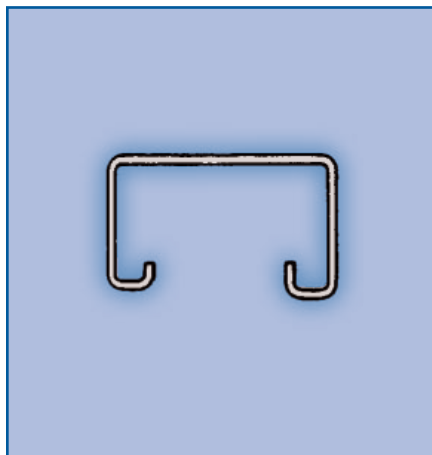

Particle Board Decking:

Penco 1-M-1 interior grade particle board is available pre-cut to fit, or purchase from your local building materials supplier. Other types and thicknesses of deck may be desired based on load or use. NOTE: Check 5/8" Particle Board capacity for the unit you require. Shelf deck capacity may not carry the rating of the steel framing. (Ordering information on page 11) If you are cutting your own board, use nominal size and cut to +0" -1/8".

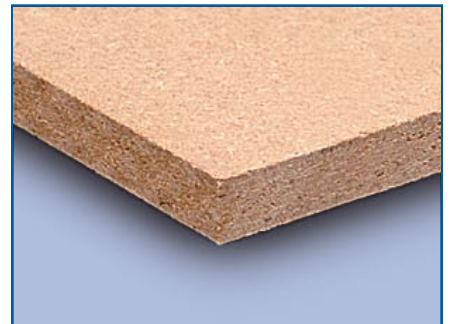

Wire Decking:

Won't trap dirt - makes overhead sprinklers more effective. Easy installation. Contact your Penco representative for more information.

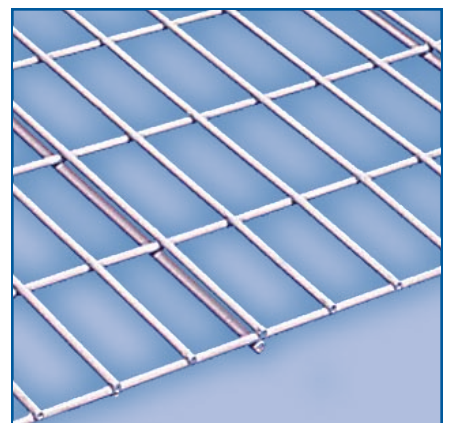

RivetRite Components

Sizes and Dimensions

| RivetRite® Components | | | | | | | | | |
|--------------------------|-----------------|-------------------|-------------------|------------------------------|-------------------------|---------------------------------|----------------------------|---------|------------------------|
| Item Desc. | Size | Standard Cat. No. | Hvy Duty Cat. No. | Item Desc. | Size | Standard Cat. No. | Item Desc. | Size | Standard Cat. No. |
| Angle Posts | 36" | 46AS03C | - | Double Rivet Channel Beams | 60" | 46CB60C | Record Storage Box Support | 15" | 46BS15 |
| | 48" | 46AS04C | - | | 69" | 46CB69C | | 30" | 46BS30 |
| | 60" | 46AS05C | - | | 72" | 46CB72C | Hanger Bar | 36" | 46BH36C |
| | 72" | 46AS06C | - | | 84" | 46CB84C | | 42" | 46BH42C |
| | 84" | 46AS07C | - | | 96" | 46CB96C | | 48" | 46BH48C |
| | 96" | 46AS08C | 46AH08C | Center Support with Hardware | 12" | 46CS12 | Beam Cleat | 60" | 46BH60C |
| | 108" | 46AS09C | 46AH09C | | 15" | 46CS15 | | Left | 46BC00C |
| | 120" | 46AS10C | 46AH10C | | 18" | 46CS18 | Right | 46BC01C | |
| | 144" | 46AS12C | 46AH12C | | 24" | 46CS24 | Slotted Angle Cleat | Left | 46SA00C |
| | 168" | - | 46AH14C | | 30" | 46CS30 | | Right | 46SA01C |
| 192" | - | 46AH16C | 32" | | 46CS32 | Down Aisle Grating Supports | 36" | 46DA36C | |
| 216" | - | 46AH18C | 36" | | 46CS36 | | 48" | 46DA48C | |
| Tee Posts | 36" | 46TS03C | - | | 42" | | 46CS42 | 60" | 46DA60C |
| | 48" | 46TS04C | - | | 48" | | 46CS48 | 69" | 46DA69C |
| | 60" | 46TS05C | - | | 12" | | 46ZB12C | 72" | 46DA72C |
| | 72" | 46TS06C | - | 15" | 46ZB15C | Shelving & Main Aisle Support | 30-1/4" x 3-1/2" | 46AX30H | |
| | 84" | 46TS07C | 46TH07C | 18" | 46ZB18C | | 36-1/4" x 3-1/2" | 46AX36H | |
| | 96" | 46TS08C | 46TH08C | 24" | 46ZB24C | | 42-1/4" x 3-1/2" | 46AX42H | |
| | 108" | 46TS09C | 46TH09C | 30" | 46ZB30C | | 48-1/4" x 3-1/2" | 46AX48H | |
| | 120" | 46TS10C | 46TH10C | 32" | 46ZB32C | Tie Plate | - | 46TP00C | |
| | 144" | 46TS12C | 46TH12C | 36" | 46ZB36C | | 36" | 46GS36C | |
| | 168" | - | 46TH14C | 42" | 46ZB42C | Deck-Over Grating Supports | 48" | 46GS48C | |
| 192" | - | 46TH16C | 48" | 46ZB48C | 60" | | 46GS60C | | |
| 216" | - | 46TH18C | 60" | 46ZB60C | 69" | | 46GS69C | | |
| Anchors | 3/8" x 2-1/4" | 9280 | - | 69" | 46ZB69C | | 72" | 46GS72C | |
| | 3/8" x 3-3/4" | 9281 | - | 72" | 46ZB72C | | 30" | 8GL030C | |
| Post Splice | 1-3/8" x 1-3/8" | 46PS0H | - | 24" | 46ZS24C | Grating Planks Non-Interlocking | 36" | 8GL036C | |
| Single Rivet Shelf Beams | 12" | 46SS12C | - | 30" | 46ZS30C | | 42" | 8GL042C | |
| | 15" | 46SS15C | - | 32" | 46ZS32C | | 48" | 8GL048C | |
| | 18" | 46SS18C | - | 36" | 46ZS36C | | 72" | 8GL072 | |
| | 24" | 46SS24C | - | 42" | 46ZS42C | | 108" | 8GL108 | |
| | 30" | 46SS30C | - | 48" | 46ZS48C | 144" | 8GL144 | | |
| | 36" | 46SS36C | 46HS36C* | 12" | 46D012C | Grating Planks Interlocking | 30" | 8AL030C | |
| | 42" | 46SS42C | 46HS42C | 15" | 46D015C | | 36" | 8AL036C | |
| | 48" | 46SS48C | 46HS48C** | 18" | 46D018C | | 42" | 8AL042C | |
| Double Rivet Angle Beams | 12" | 46SB12C | - | 24" | 46D024C | | 48" | 8AL048C | |
| | 15" | 46SB15C | - | 30" | 46D030C | | 72" | 8AL072 | |
| | 18" | 46SB18C | - | 32" | 46D032C | 108" | 8AL108 | | |
| | 24" | 46SB24C | - | 36" | 46D036C | 144" | 8AL144 | | |
| | 30" | 46SB30C | - | 42" | 46D042C | 3" Wide Grating Fillers | 30" | 8FK030C | |
| | 32" | 46SB32C | - | 48" | 46D048C | | 36" | 8FK036C | |
| | 36" | 46SB36C | - | 48" | 46TB48C | | 42" | 8FK042C | |
| | 42" | 46AB42C*** | - | 60" | 46TB60C | | 48" | 8FK048C | |
| | 42" | 46SB42C | - | 9-1/4" | 46WT09C | | 72" | 8FK072 | |
| | 48" | - | 46HB48C | Flue Spacing Components | 6" | 46RT06 | 108" | 8FK108 | |
| 60" | - | 46HB60C | 6" | | 46AX153 | 144" | 8FK144 | | |
| 69" | - | 46AB69C*** | Tire Rack Beams | 9-1/4" | 46RT09C | Self-Tap Screws | - | 08822 | |
| 69" | - | 46HB69C | | 15-1/4" | 46RT15C | | Wire Decking | - | Contact your Penco Rep |
| 72" | - | 46HB72C | 18-1/4" | 46RT18C | Double Row and Top Ties | - | | - | |
| 84" | - | 46HB84C | 36-1/4" | 46RT36C | | | | | Foot Plate |
| 96" | - | 46HB96C | - | 46FP0H | | | | | |

* Heavy Duty 36" support beam capacity is 600 lb. per pair.
 ** Heavy Duty 48" support beam capacity is 500 lb. per pair.
 *** Punched for Box Supports



Technical Information

Unit Clear Width

EXAMPLES BELOW ARE BASED ON 36" WIDE SHELF

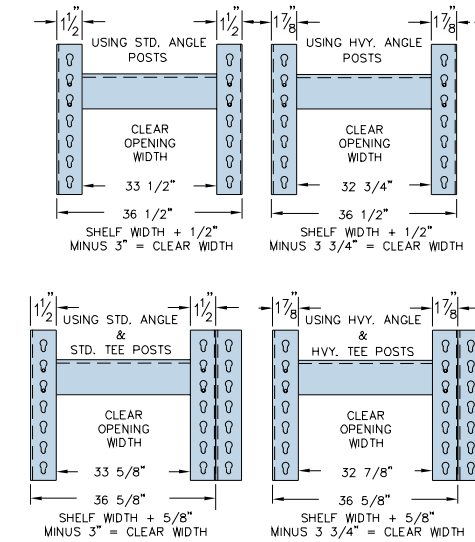

Beam Profiles

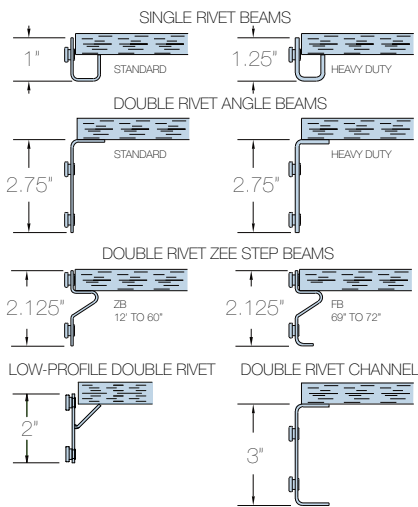

Vertical Clear Opening Using 5/8" Shelf Deck Material

UNITS USING SINGLE RIVET SHELF BEAMS

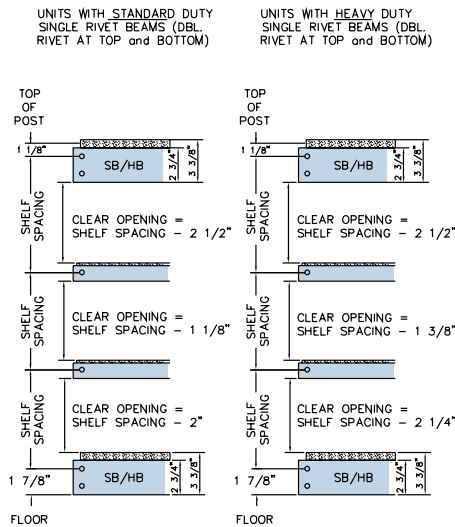

UNITS USING ZEE, ANGLE AND CHANNEL BEAMS

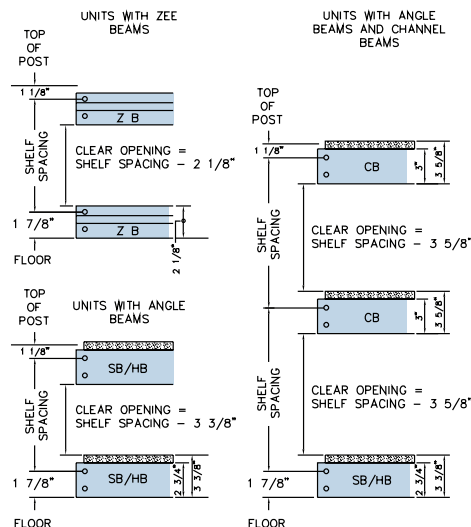

VERTICAL SHELF CLEARANCE

THIS CHART DEPICTS SHELF CLEARANCES FOR TYPICAL RIVET RITE SHELVING UNITS WITH 1 1/2" VERTICAL SHELF ADJUSTMENT.

SINGLE RIVET HIGH DENSITY SHELVING UNITS

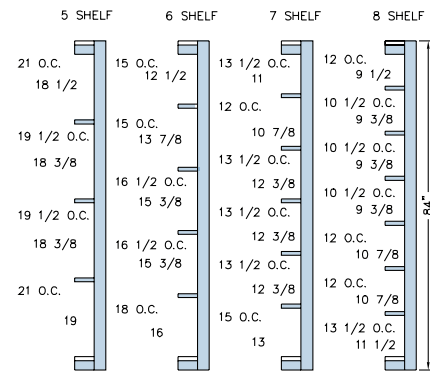

DOUBLE RIVET BULKY SHELVING UNITS

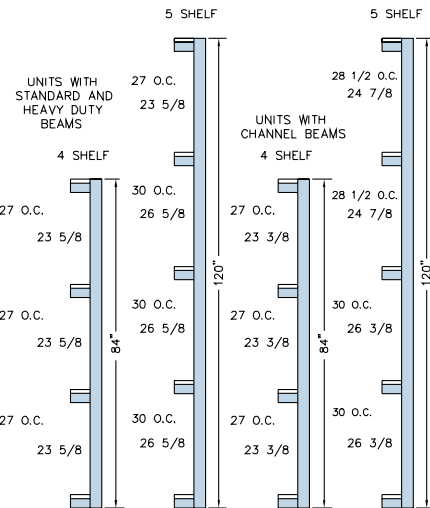

Unit Growth Chart

WHEN DESIGNING A SHELVING LAYOUT, UNIT GROWTH MUST BE CONSIDERED. TO DETERMINE THE OVERALL DIMENSION OF A CONTINUOUS ROW OF SHELVING EMPLOYING TEE POSTS OR ANGLE POST WITH TIE PLATES.

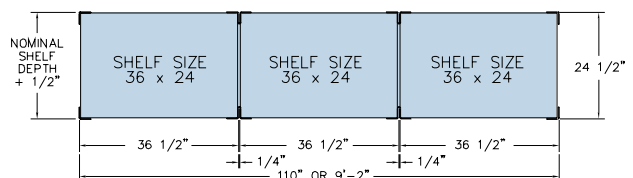

21 Designer Colors



NOTE: Colors shown are as close to actual finishes as the printing process allows. Do not make your final color selection based on the color shade shown on this page. Penco Color Charts are available for a more accurate color match. Exposure to high humidity, chlorine salts, abrasive cleaners, germicidal cleaners and acids can damage the finish and will void the guarantee. For outdoor applications or other harsh environmental conditions, contact your Penco Representative.

Standard Colors

To assure rust resistance and paint adhesion, all RivetRite shelving receives a state of the art pre-paint conditioning that includes a thorough cleansing by a hot spray washing process, then a coating with a special phosphate film for resistance to corrosion and improved paint bond strength.

RivetRite is available in 21 colors shown above. Mixed colors of vertical and horizontal are available through special request.

Penco's 1 mil thick paint finish is perfect for most applications. The paint surface is tough and durable and offers a beautiful drip-free

surface, excellent edge coverage and environmentally friendly application.



QuickShip Program

| Double Rivet Bulky Storage Units (With 4 Shelves - 84" High) | | | | | |
|---|-------------|------------------------|-----------------|---------------------|-----------------|
| | | WITHOUT Center Support | | WITH Center Support | |
| Unit Width | Shelf Depth | Starter Cat. No. | Add-On Cat. No. | Starter Cat. No. | Add-On Cat. No. |
| 48" Wide Units | 18" | 46001HP | 46006HP | 46W01HP | 46W06HP |
| | 24" | 46002HP | 46007HP | 46W02HP | 46W07HP |
| | 30" | 46003HP | 46008HP | 46W03HP | 46W08HP |
| | 36" | 46004HP | 46009HP | 46W04HP | 46W09HP |
| 60" Wide Units | 18" | 46011HP | 46016HP | 46W11HP | 46W16HP |
| | 24" | 46012HP | 46017HP | 46W12HP | 46W17HP |
| | 30" | 46013HP | 46018HP | 46W13HP | 46W18HP |
| | 36" | 46014HP | 46019HP | 46W14HP | 46W19HP |
| 72" Wide Units | 18" | 46021HP | 46026HP | 46W21HP | 46W26HP |
| | 24" | 46022HP | 46027HP | 46W22HP | 46W27HP |
| | 30" | 46023HP | 46028HP | 46W23HP | 46W28HP |
| | 36" | 46024HP | 46029HP | 46W24HP | 46W29HP |
| 96" Wide Units | 18" | - | - | 46W31HP | 46W36HP |
| | 24" | - | - | 46W32HP | 46W37HP |
| | 30" | - | - | 46W33HP | 46W38HP |
| | 36" | - | - | 46W34HP | 46W39HP |
| | 48" | - | - | 46W35HP | 46W40HP |

- 72 hours or less rapid turnout time
- Reduced freight costs and shorter shipping times due to strategically located warehouses across North America
- Penco's most popular items in stock, including Clipper and RivetRite shelving, Vanguard and Plastic Lockers
- Think Quick, Think Penco QuickShip!

| Double Rivet Bulky Storage Units (With 5 Shelves - 120" High) | | | | | |
|--|-------------|------------------------|-----------------|---------------------|-----------------|
| | | WITHOUT Center Support | | WITH Center Support | |
| Unit Width | Shelf Depth | Starter Cat. No. | Add-On Cat. No. | Starter Cat. No. | Add-On Cat. No. |
| 72" Wide Units | 30" | 46041HP | 46044HP | 46W41HP | 46W44HP |
| | 36" | 46042HP | 46045HP | 46W42HP | 46W45HP |
| | 48" | 46043HP | 46046HP | 46W43HP | 46W46HP |
| 96" Wide Units | 30" | - | - | 46W47HP | 46W50HP |
| | 36" | - | - | 46W48HP | 46W51HP |
| | 48" | - | - | 46W49HP | 46W52HP |

| Single Rivet High Density Units (With Double Rivet Beams at Top/Bottom - 84" High) | | | | | |
|---|-------------|------------------|------------------|------------------|------------------|
| Unit Width | Shelf Depth | 5 Shelf Cat. No. | 6 Shelf Cat. No. | 7 Shelf Cat. No. | 8 Shelf Cat. No. |
| 36" Starter Units | 12" | 461315P | 461316P | 461317P | 461318P |
| | 18" | 461325P | 461326P | 461327P | 461328P |
| | 24" | 461335P | 461336P | 461337P | 461338P |
| | 36" | 461345P | 461346P | 461347P | 461348P |
| 36" Add-On Units | 12" | 462355P | 462356P | 462357P | 462358P |
| | 18" | 462365P | 462366P | 462367P | 462368P |
| | 24" | 462375P | 462376P | 462377P | 462378P |
| | 36" | 462385P | 462386P | 462387P | 462388P |
| 48" Starter Units | 12" | 461415P | 461416P | 461417P | 461418P |
| | 18" | 461425P | 461426P | 461427P | 461428P |
| | 24" | 461435P | 461436P | 461437P | 461438P |
| | 36" | 461445P | 461446P | 461447P | 461448P |
| 48" Add-On Units | 12" | 462455P | 462456P | 462457P | 462458P |
| | 18" | 462465P | 462466P | 462467P | 462468P |
| | 24" | 462475P | 462476P | 462477P | 462478P |
| | 36" | 462485P | 462486P | 462487P | 462488P |

| Archive Shelving Units (For Use with Decking - 84" High) | | |
|---|-------------|------------------|
| Unit Width | Shelf Depth | 5 Shelf Cat. No. |
| 42" Starter Units | 15" | 46601AP |
| | 30" | 46602AP |
| 42" Add-On Units | 15" | 46613AP |
| | 30" | 46614AP |
| 69" Starter Units | 15" | 46603AP |
| | 30" | 46604AP |
| 69" Add-On Units | 15" | 46615AP |
| | 30" | 46616AP |

NOTE: Shelf Deck material is not included with the units. Order Particle Board separately. Nominal Size in Inches: Width, Depth, Height. Contact your Penco Representative for more information.

| Particle Board Decking for QuickShip Units (5/8" Thick - Other Sizes Available) | | | | | | | |
|--|----------|-----------|----------|-----------|----------|-----------|----------|
| Size | Cat. No. | Size | Cat. No. | Size | Cat. No. | Size | Cat. No. |
| 36" x 12" | 94603 | 42" x 15" | 94614 | 48" x 30" | 94627 | 60" x 30" | 94637 |
| 36" x 18" | 94605 | 42" x 30" | 94617 | 48" x 36" | 94628 | 60" x 36" | 94638 |
| 36" x 24" | 94606 | 48" x 12" | 94623 | 48" x 48" | 94629 | 60" x 48" | 94639 |
| 36" x 30" | 94607 | 48" x 18" | 94625 | 60" x 18" | 94635 | 69" x 15" | 94644 |
| 36" x 36" | 94608 | 48" x 24" | 94626 | 60" x 24" | 94636 | 69" x 30" | 94647 |

Penco

Storage Products



Industrial Shelving

Penco Products manufactures a wide variety of shelving products.

Clipper® and Erectomatic® Hi-Performance® shelving feature adjustable strong box beam shelves and post systems capable of supporting high-rise and multi-level installations. Wide Span shelving specializes in storing goods that are wide, high and bulky with extreme ease of assembly. RivetRite® boltless shelving's simple design offers an economical solution to most storage problems, from the small back room to the multi-level archive storage system.



Pallet Rack

Penco pallet rack is a carefully engineered system designed to provide highly efficient storage of palletized items. High strength steel and efficient design achieve a superior strength-to-weight ratio that makes Penco Rack one of the best values for your storage dollar. A wide range of sizes, capacities and accessories enables Penco pallet rack to handle virtually any job you can give it.



Shop Furniture

Penco's products in the Shop Furniture line can make your work environment more comfortable and efficient. Various configurations of work benches, carts and stools can be combined to help organize any work area for maximum productivity.



Lockers

Penco Vanguard™ Lockers have been a standard in the industry for decades. They have spawned many other locker models suitable for school corridors, athletic teams, employees, health clubs and hospitals. These include Guardian™, Invincible™, Stadium®, All-Welded, Angle Iron, ProTough® and the SmartLockers® electronic locker system. Penco steel lockers are beautifully finished in powder coat enamel in 21 decorator colors.

Penco also has plastic lockers. They are an exclusive Penco design manufactured from high density polyethylene (HDPE) which is rust proof and resistant to most common chemicals and cleaners. They are available in 7 standard colors. Many sizes of Penco lockers are available on a QuickShip basis from our strategically located warehouses.



Storage Cabinets

Penco's E-Z Bilt Cabinets are an ideal solution to storage needs in offices, plants, schools and institutions. The contemporary design and attractive powder coat baked enamel finish is compatible with any decor. Design features include a recessed handle with built-in lock and two keys. Available in several models and sizes.



Metal Fabrication Group

Corporate Information



Industrial Manufacturing Company (IMC)

The parent company of Penco and its affiliates in the Metal Fabrication Group is Industrial Manufacturing Company (IMC). IMC and its international arm, IMCI, are a proud family of companies that produce a wide variety of innovative products for industry. With more than 3,500 employees and 30 worldwide manufacturing, sales and distribution facilities, it produces aircraft and aerospace ducting systems, gears, lubrication systems, bleachers, steel and plastic lockers, storage systems, steel mezzanines, high-performance strainers, car and truck components, industrial hoses and industrial expansion joints.

Although each IMC and IMCI company operates independently, common to all of them is a profound respect for the integrity of established industrial principles and a practical openness to applications of new technology. With individual histories spanning decades – and in two cases more than a century – the IMC and IMCI companies are time-tested leaders in their national and global markets.

Each IMC and IMCI subsidiary strives to tailor its products and services to the wishes of its customers, and each company's success has been built on the development of enduring customer relationships. They take pride in providing not only products of consistently high quality, but also in flexible and responsive service and in realistically competitive prices.

All Star Bleachers, Inc.

For more than 50 years, All Star has been a leading designer and manufacturer of bleachers and grandstands for indoor

and outdoor seating applications. All Star takes pride in providing products of consistently high quality, responsive service and realistically competitive prices. Products range from a simple team bench to a grandstand that meets the VIP seating requirements of a NASCAR race. Visit www.allstarbleachers.com

Schmidt Structural Products, Inc.

For over 40 years, Schmidt Structural Products, Inc. (formerly W.A. Schmidt) has designed, manufactured and installed structural steel mezzanines to vertically expand floor space quickly and economically. A mezzanine can double or even triple existing space at up to 80% less than the cost of a building addition. Visit www.schmidtstructural.com

Quality Metal Products

Quality Metal Products (QMP) designs and manufactures storage equipment and outdoor shelters for use in the workplace. Its metal fabricated products include lockers, storage cabinets, modular drawers, work benches, bicycle racks and shelters. Market sectors served by QMP include educational, health, and government facilities, as well as offices, manufacturing companies, retail outlets, sports arenas and community parks.

Established in 1958, QMP is located in the West Midlands, the historical heartland of manufacturing in the UK. Their manufacturing facility occupies over 107,000 square feet and includes state-of-the-art metal fabrication equipment including CNC blanking and CNC forming in addition to powder coating and robotic welding.

Visit www.qmp.uk.com





www.pencoproducts.com



Stack it, Store it, Secure it.

Established in 1869, Penco Products, Inc. is based in Skippack, PA with manufacturing facilities in North Carolina and Utah. Penco is a leader in the design and fabrication of a wide spectrum of storage products ranging from industrial shelving, pallet rack and work benches to lockers for every need.

Penco's products are available through a nationwide network of distributors, serviced by a team of District Sales Managers. Penco's mission is to provide customers with value in the form of the finest storage products available. Whether you need to Stack it, Store it or Secure it, you can put the load on Penco.



Corporate Headquarters

2024 Cressman Road
Skippack, PA 19474
800.562.1000

Manufacturing Facilities

Eastern United States

North Carolina Plant
1301 Penco Drive
Hamilton, NC 27840

Western United States

Utah Plant
4080 West Farm Road
Salt Lake City, UT 84088

QuickShip Distribution Centers

Northeast

Pennsylvania QuickShip
3820 Hempland Road
Mountville, PA 17554

Southeast

North Carolina QuickShip
1301 Penco Drive
Hamilton, NC 27840

South

Tennessee QuickShip
5355 Distriplex Farms Drive
Memphis, TN 38141

Texas

Texas QuickShip
6615 Roxburgh, Suite 200
Houston, TX 77041

West

Utah QuickShip
4080 West Farm Road
Salt Lake City, UT 84088



PENCO PRODUCTS, INC. PHONE: 800-562-1000 • FAX: 800-248-1555 • E-MAIL: general@pencoproducts.com

