

Presto LIFTS **ECO A**

P4 Floor Height Load Leveler Owner's Manual



Model: _____
Serial Number: _____
Date placed in service: _____

Presto Lifts Inc.
50 Commerce Way, Norton, MA 02766
Phone: 800.343.9322
Fax: 888.788.6496
www.PrestoLifts.com
Email: service@prestolifts.com

Contents

1	Introduction.....	4
1.1	Responsibilities of Owner and Users.....	4
1.2	Responsibilities of Operators.....	5
2	Safety.....	7
2.1	Safety Alert Symbols.....	7
2.2	Signal Words.....	7
2.3	Safety Devices.....	7
3	Labeling.....	7
3.1	Label Placement Diagram.....	8
4	Installation.....	9
5	Operation.....	10
5.1	Relocating the Machine.....	11
5.2	Loading.....	12
5.3	Raising and Lowering the platform.....	12
6	Maintenance & Repair.....	12
6.1	Periodic Maintenance.....	13
6.1.1	Monthly.....	13
6.1.2	Annually.....	13
6.2	Relieving Hydraulic System Pressure.....	14
6.3	Cleaning the Down Valve.....	15
6.4	Replacing Hydraulic Fluid.....	15
6.5	Ordering Replacement Parts.....	16
7	Troubleshooting.....	16
8	Electrical.....	18
8.1	Wiring Schematic.....	18
9	Hydraulics.....	18
9.1	Hydraulic Power Unit.....	19
9.2	Hydraulic Schematic.....	19
10	Components.....	20
11	Warranty & Contact Information.....	21



**This label (part # 10095524)
is required by California law.
For more information visit
www.P65Warnings.ca.gov.**

1. Introduction

1.1 Responsibilities of Owner and Users

Basic Principles - Owners/users shall apply sound principles of safety, training, inspection, maintenance, and expected operating environment. It shall be the responsibility of the owner/user to advise the manufacturer where deflection may be critical to the application.

Manuals - Owners/users shall keep and maintain a copy of the operating and maintenance manual(s) and ensure its availability to operating and maintenance personnel.

Inspection and Maintenance - It shall be the responsibility of the users to inspect and maintain the machine as required to ensure proper operation. The frequency of inspection and maintenance shall be based upon the manufacturer's recommendations and be compatible with operating conditions and the severity of the operating environment. Machinery that is not in proper operating condition shall be immediately removed from service until repaired. Maintenance and repairs shall be made by a qualified person and the repairs shall be in conformance with the manufacturer's recommendations.

Maintenance Safety Precautions - Before adjustments and repairs are started on the machine, the following precautions shall be taken as applicable:

1. Remove the load from the load enclosure.
2. Lower platform to the full down position.
3. Relieve system pressure from all circuits before loosening or removing any components.
4. All controls in the "off" position and all operating features secured from inadvertent motion by brakes, blocks, or other means.
5. Disconnect power and follow established owner/user lockout/tag out policies.
6. Follow precautions and directions as specified by the manufacturer.

Replacement Parts - When parts or components are replaced, they shall be replaced with parts or components approved by the original manufacturer.

Maintenance Training - The user shall ensure only qualified personnel inspect and maintain the machine in accordance with the manufacturers recommendations.

Operator Training - An owner/user, who directs or authorizes an individual to operate the machine shall ensure that the individual has been:

1. Trained in accordance with the manufacturer's operating manual.
2. Made aware of the responsibilities of operators as outlined in section 1.4 of this manual.
3. Retrained, if necessary, based on the owners/user's observation and evaluation of the operator.

Modifications and additions shall not be performed without the manufacturer's prior written approval. Where such authorization is granted, capacity, operation, and maintenance instruction plates, tags, or decals shall be changed accordingly.

1.2 Responsibilities of Operators

Basic Principles - Operators shall apply sound principles of safety and good judgment in the application and operation of the machine with consideration given to its intended use and expected operating environment. Since the operator is in direct control of the machine, conformance with good safety practices is the responsibility of the operator. The operator shall make decisions on the use and operation with due consideration for the fact that his or her own safety as well as the safety of other personnel on or near the machine is dependent on those decisions.

General Training - Only personnel who have received general instructions regarding the inspection, application and operation of machine, including recognition and avoidance of hazards associated with their operation, shall operate the machine. Such topics covered shall include, but not necessarily be limited to, the following issues and requirements:

1. A pre-start inspection
2. Responsibilities associated with problems or malfunctions affecting the operation of the machine.
3. Factors affecting stability
4. The purpose of placards and decals
5. Workplace inspection
6. Safety rules and regulations
7. Authorization to operate
8. Operator warnings and instructions
9. Actual operation of the machine. Under the direction of a qualified person, the trainee shall operate the machine for a sufficient period of time to demonstrate proficiency in actual operation of the machine.

Pre-start Inspection - Before use each day or at the beginning of each shift, the machine shall be given a visual inspection and functional test including but not limited to the following:

1. Operating and emergency controls
2. Safety devices
3. Hydraulic system leaks
4. Electrical cables and wiring harness
5. Loose or missing parts
6. Nameplates, precautionary and instructional markings and/or labeling
7. Guarding system
8. Items specified by the manufacturer

Problem or Malfunctions - Any problems or malfunctions that affect the safety of operations shall be repaired prior to the use of the machine.

Before Operations - The operator shall:

1. Read and understand the manufacturer's operating instruction(s) and user's safety rules or have them explained
2. Understand all labels, warnings, and instructions displayed on the machine or have them explained.

Workplace Inspections - Before the machine is used and during use, the operator shall check the area in which the machine is to be used for possible hazards such as, but not limited to:

1. Bumps, floor obstructions and uneven surfaces
2. Overhead obstructions and electrical hazards
3. Presence of unauthorized persons
4. Other possible unsafe conditions as noted in the operating manual.

Operator Warnings and Instructions - The operator shall ensure the operation of the machine is in compliance with the following:

Guarding system - Guarding shall be installed and positioned, and access gates or openings shall be secured per the manufacturer's instructions.

Distribution of load - The load and its distribution on the platform shall be in accordance with the manufacturer's rated capacity for that specific configuration.

Maintaining overhead clearance - The operator shall ensure that adequate clearance is maintained from overhead obstructions and energized electrical conductors and parts.

Point of Operation - The operator shall not place any part of their body under the platform.

Precaution for moving equipment - When other moving equipment or vehicles are present, special precautions shall be taken to comply with the safety standards established for the workplace.

Reporting problems or malfunctions - The operator shall immediately report to a supervisor any problem(s) or malfunction(s) that become evident during operation. The operator shall ensure all problems and malfunctions that affect the safety of operations are repaired prior to continued use.

Capacity limitation - Rated capacity shall not be exceeded when loads are transferred to the load enclosure.

Work area - The operator shall ensure the area surrounding the machine is clear of personnel and equipment before lowering the load enclosure.

Securing the machine - The operator shall comply with the means and procedures provided to protect against use by an unauthorized person(s).

Altering safety devices - Safety devices shall not be altered or disabled.

Modifications or alterations of the machine or the fabrication and attaching of frameworks or the mounting of attachments to the machine or the guarding system shall only be accomplished with prior written permission of the manufacturer.

Assistance to the operator - If an operator encounters any suspected malfunction or any hazard or potentially unsafe condition relating to capacity, intended use or safe operation the operator shall cease operation of the machine and request further instruction from the owner/user.

Problems or malfunctions - Any problem(s) or malfunction(s) that affect the safety of operations shall be repaired prior to the use of the machine.

2. Safety

All personnel installing, operating, and maintaining this machine shall read and understand this manual. For questions or concerns contact the manufacturer.

This machine shall be installed, operated, and maintained by trained and/or qualified personnel only.

2.1 Safety Alert Symbols

A symbol that indicates a hazard. It is composed of an equilateral triangle surrounding an exclamation mark. The safety alert symbol is only used on hazard alerting signs. It is not used on safety notice and safety instructions signs.



A – For use with **DANGER** signal word; (safety white triangle, safety red exclamation mark, safety red background)

B – For use with **WARNING** signal word; (safety black triangle, safety orange exclamation mark)

C – For use with **CAUTION** signal word; (safety black triangle, safety yellow exclamation mark)

D – For use with **DANGER, WARNING, or CAUTION** signal words; (**D** is a safety yellow triangle with a safety black border and safety black exclamation mark;

2.2 Signal Words



DANGER Indicates a hazardous situation that, if not avoided, will result in death or serious injury.



WARNING Indicates a hazardous situation that, if not avoided, could result in death or serious injury.



CAUTION Indicates a hazardous situation that, if not avoided, could result in minor or moderate injury.



NOTICE Indicates information considered important, but not hazard-related (e.g., messages relating to property damage).

2.3 Safety Devices

This machine is equipped with devices and features to protect the operator and nearby personnel from severe injury or death. These features and devices shall be installed and functioning correctly during operation.

Photo Eye Toe Protection: This machine is equipped with a photo eye across the front opening. This photo eye detects when there is an obstruction in the path of the platform and prevents the platform from raising or lowering until the obstruction is cleared.

3. Labeling

This machine has labeling to indicate potential hazards this machine may pose when operating and/or maintaining the machine. All labels must be legible. If any label is missing, damaged, or otherwise illegible contact the manufacturer for replacement labels.

3.1 Label Placement Diagram

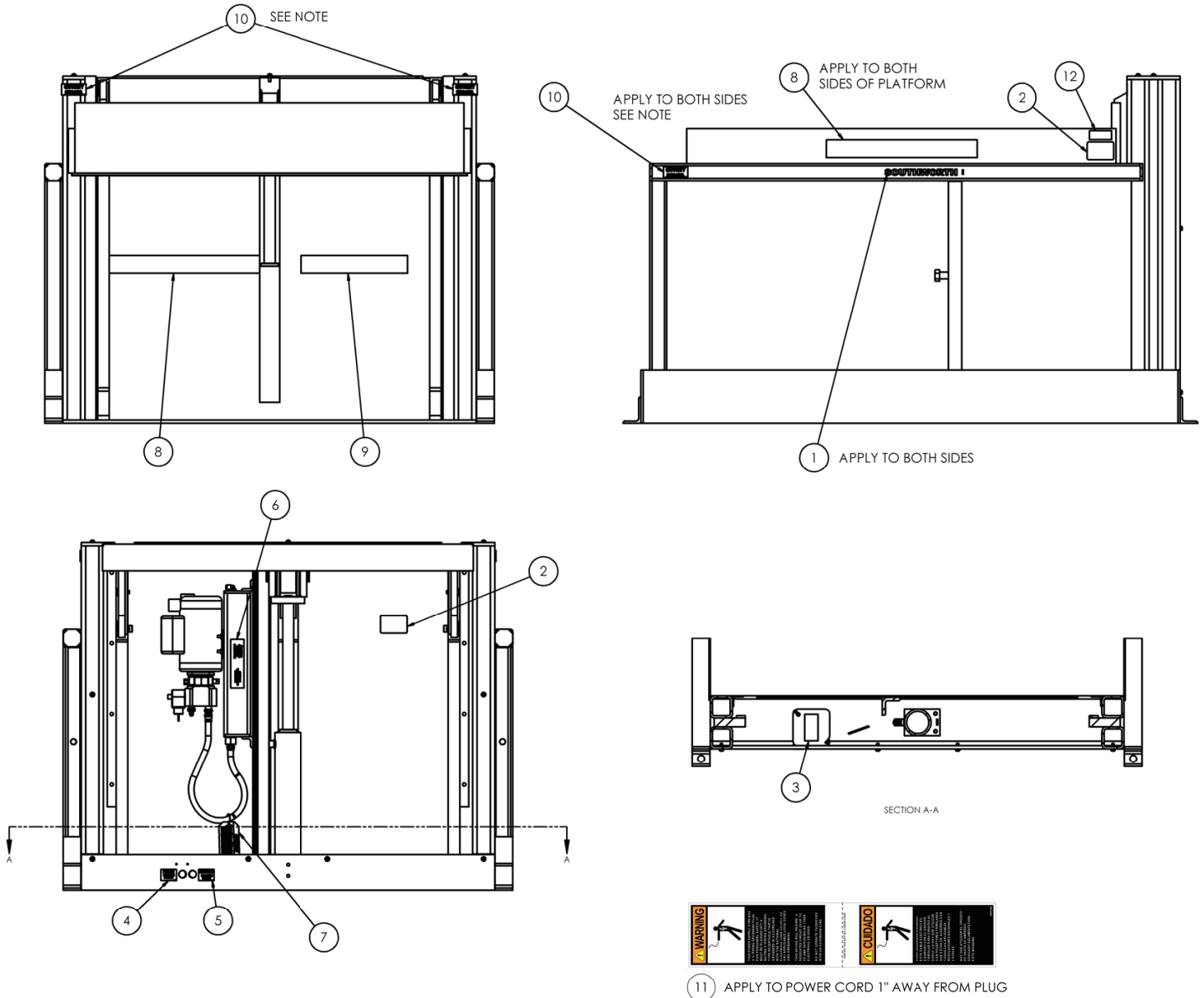

NOTE:

**CAPACITY
2500 LBS.**

**CAPACITY
4000 LBS.**

USE PART NO. 2998435
FOR 2500 LB CAPACITY
MACHINES

USE PART NO. 2998426
FOR 4000LB CAPACITY
MACHINES

12	1	EA	LD WARNING CANCER AND REPRODUCTIVE	10095524
11	1	EA	BK-LD DCL 2.50X12.75 (ENGLISH AND SPANIS	10021381
10	4	EA	BK-LD DCL 1.25X2.75 CAPACITY	
9	1	EA	BK-LD DCL 2.00X12.00 A DANGER	5904643
8	3	EA	BK-LD DCL 2.00X17.00 TO AVOID BODILY INJ	2986306
7	1	EA	LD DCL 2.50X5.00 PROPER INSTALLATION IS	2998365
6	1	EA	BK-LD DCL 1.50X5.50 TANK TO BE FULL ONLY	2986997
5	1	EA	BK-LD DCL 1.25X1.75 CONTROL, 115V 1 PHAS	2986999
4	1	EA	BK-LD DCL 1.25X1.75 POWER	2987000
3	1	EA	BK-LD DCL 3.00X1.50 ARC FLASH AND SHOCK	10047672
2	2	EA	LD DCL 2.00X3.00 PRESTO SERIAL ID BLANK	10079930
1	2	EA	BK-LD 1.62X7.00 PRESTO ALPHA	C180N
ITEM NO.	QTY.	U/M	DESCRIPTION	PART NO.

4. Installation

Before Installation read and understand this manual. **Only trained and/ or qualified personnel shall install this machine.** Remove all packaging and inspect the machine for damage and/ or missing components. Contact the manufacturer if damage is found or components are missing.

The owner/ installer is responsible for ensuring all codes and ordinances are met and any necessary permits are obtained prior to installation.

Anchoring this machine is optional. Four anchor holes are provided if anchoring the machine is preferred.

⚠ DANGER

Electric motors can create sparking, do not install in an area where flammable materials are present.

This machine must be installed in an area protected from rain and moisture.

This machine must be installed and operated on a solid, level surface capable of supporting the machine and it's maximum rated capacity.

Do not sit, stand, or ride on the platform.

Fork trucks, pallet jacks, or other lifting devices used for moving this machine must be capable of lifting 2000 lb. minimum.

Machines equipped with 1HP 115/1/60 power units must be powered using a dedicated circuit with a 20 amp breaker.

Do not power this machine with an extension cord or the motor and other electrical components may be damaged.

Do not enter beneath the platform.

This machine is shipped with two bolts threaded into inside of each side panel. These bolts allow for the lifting of the machine.

To remove the machine from the shipping pallet:

1. Unfasten the machine from the pallet.
2. Plug the machine in and raise the platform until the vertical sides just come in contact with the bolts.

NOTICE

Do not continue to power the machine after the platform contacts the bolts or the machine may be damaged.

3. Unplug the machine and store the power cord so it does not get damaged during transport.
4. Carefully insert the forks of a fork truck under the platform and raise the forks until they come in contact with the bottom of the platform.

NOTICE

Insert forks completely and ensure the machine's center of mass is supported when transporting.

5. Continue to carefully raise the forks until the machine raises off of the pallet.

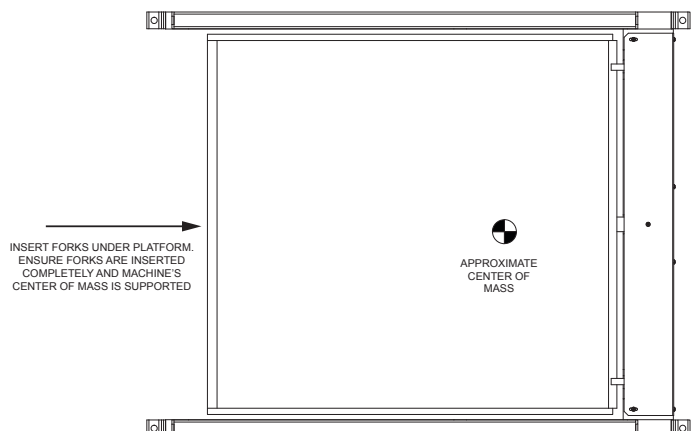

6. Carefully move the machine to the desired location.

This machine may be operated without being anchored. If anchoring the machine is desired:

1. With the machine in the desired position mark the anchor holes located at each corner of the machine.
2. Move the machine and drill holes for the anchors.
3. Move the machine back into position and anchor the machine using appropriate anchors.

Once the machine has been positioned plug the machine in, lower the platform to the fully lowered position and remove the two bolts. These bolts can be stowed in the holes in the center vertical post on the outside of the side panels.

NOTICE

The two bolts must be removed before attempting operate the machine or the machine may be damaged.

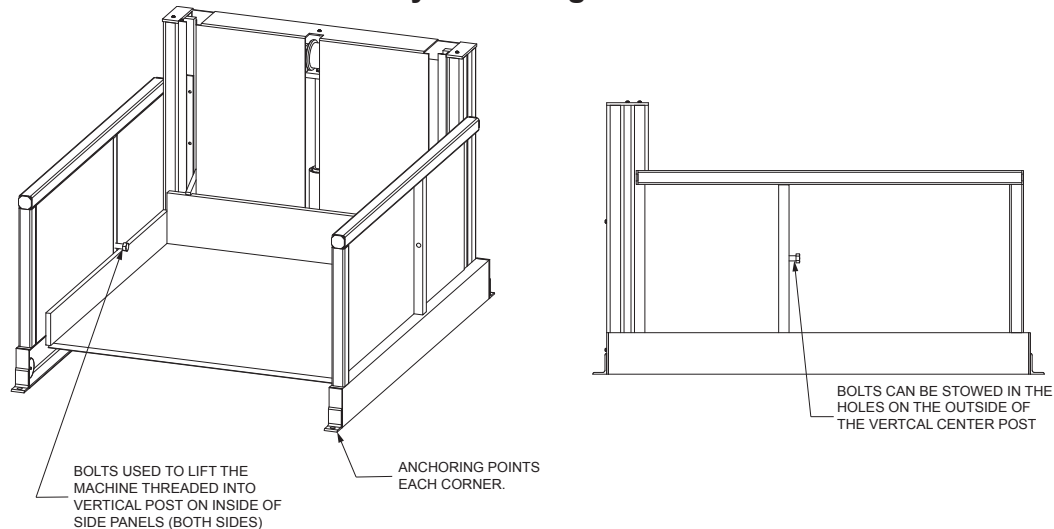

5. Operation



Crush, pinch, and shear points exist; keep hands, feet, and loose clothing away from machine during operation.

Do not enter beneath the platform.

Verify the area around the machine is clear of debris and/ or personnel before operating.

The two bolts used to relocate the machine must be removed before operating the machine or the machine may be damaged.

Only trained and/ or qualified personnel shall operate this machine. Personnel operating this machine must read and understand this manual.

Do not sit, stand, or ride on platform.

Before each use, inspect the machine for excessive wear or damage. Verify all precautionary labeling is legible. Verify the photo eye across the load opening is functioning correctly by placing an object in the path of the light and attempting to raise and lower the platform. The platform must not lower or raise if the photo eye is obstructed.

5.1 Relocating the Machine

CAUTION Always remove the load before attempting to relocate the machine.

This machine may be relocated as necessary. To move the machine:

1. Lower the platform to the fully lowered position.
2. Remove the lifting bolts from their stowed position and thread them into the holes on the inside of the vertical posts of the side panels.

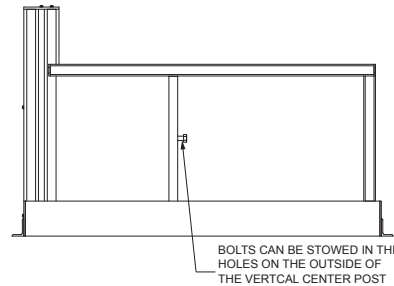
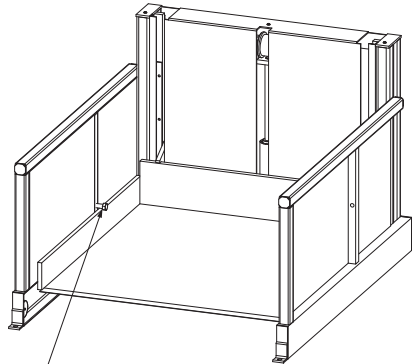

3. Plug the machine in and raise the platform until the vertical sides of the platform come in contact with the bolts.

NOTICE

Do not continue to power the machine after the platform contacts the bolts or the machine may be damaged.

4. Unplug the machine and store the power cord so it does not get damaged during transport.
5. Carefully insert the forks of a fork truck or pallet jack under the platform and raise the forks until they come in contact with the bottom of the platform.

NOTICE

Insert forks completely and ensure the machine's center of mass is supported when transporting.

6. Continue to carefully raise the forks until the machine raises off of the floor.
7. Carefully move the machine to the desired location.

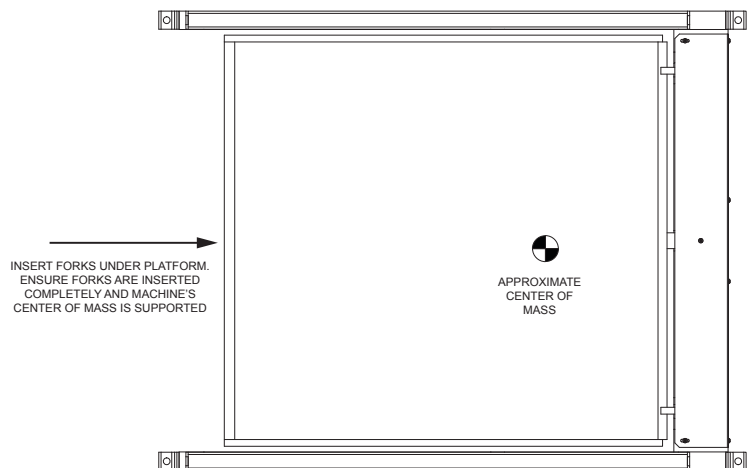

Once the machine has been positioned, plug the machine in, lower the platform to the fully lowered position and remove the two bolts and stow them in the holes in the center vertical post on the outside of the side panels.

NOTICE

The two bolts must be removed before attempting operate the machine or the machine may be damaged.

5.2 Loading

WARNING

Loads must not exceed the rated capacity. Overloading can cause damage or failure, which may lead to severe injury.

Any load that may shift during raising or lowering must be secured.

When loading the machine, the load must be centered on the platform. If the load is uneven the heaviest part of the load is to be placed toward the mast of the machine to avoid excessive deflection. Due to the cantilever design, some deflection will occur.

5.3 Raising and Lowering the platform

NOTICE

The photo eye along the front edge of the platform must be clear before the machine will operate.

To raise the platform press and hold the UP button on the controls.

To lower the platform press and hold the DOWN button on the controls. The motor does not run while lowering the platform.

6. Maintenance & Repair

DANGER

To avoid death or serious injury:

- High Voltage can cause severe injury or death. Disconnect and lockout electrical power before performing maintenance or repair.
- Only trained and/ or qualified personnel shall perform and maintenance or repair.
- High pressure fluids can penetrate skin and cause severe injury or death. Always relieve hydraulic system pressure before performing maintenance or repair of the hydraulic system. See Relieving Hydraulic System Pressure section.
- Never enter beneath the raised platform.
- If damage or excessive wear is found, remove the machine from service until the machine is repaired.

NOTICE

All maintenance too be performed with the platform in the fully lowered position.

6.1 Periodic Maintenance

Before each use

- Inspect the machine for excessive wear or damage.
- Verify all precautionary labeling is legible.
- Verify the photo eye across the load opening is functioning correctly by placing an object in the path of the light and attempting to raise and lower the platform. The platform must not raise or lower if the photo eye is obstructed. **See Operation Section.**

6.1.1. Monthly

- Inspect the rollers and roller tracks, cylinder sheave, and chain. **See Hydraulic Power Unit and Components sections.**
- Inspect mast, out-riggers, and other structure components for damage, broken welds, etc.
- Inspect all hydraulic fittings and connections for leaks or damage.
- Inspect the hydraulic cylinder. Excessive fluid in the vent line may indicate leaking seals within the cylinder.
- Inspect the hydraulic fluid. Fluid level should be approximately 3/4 of an inch from the top of the reservoir when the platform is lowered. Fluid should be clear and free of debris. Fill tank only when platform is lowered.
- Check, operator push button or foot switch for proper operation. Inspect all wiring for secure connections and sound wiring, including grounds and electrical components.

6.1.2. Annually

- Perform Monthly inspections.
- Change the hydraulic fluid and clean the suction strainer. **See Replacing Hydraulic Fluid Section.**

6.2 Relieving Hydraulic System Pressure

If the machine is operating normally, hydraulic system pressure can be relieved by lowering the platform to the fully lowered position and continuing to hold the down button for five seconds.

If the platform is raised and will not lower:

⚠ DANGER To avoid death or serious injury:

- **Crush Hazard – Do not enter under the platform.**
- **Remove load before performing any maintenance or repair.**
- **Disconnect and lockout electrical power before performing maintenance or repair.**
- **Failure to securely block the platform from lowering will allow the platform to fall uncontrolled when system pressure is relieved, potentially causing severe injury or death. Blocking/cribbing chosen must be able to safely support a 1000 lb. static load.**
- **High pressure fluid can cause severe injury or death. Always use proper personal protective equipment when performing any maintenance or repair.**
- **Take care not to damage the platform when using fork lift for support.**

Check to make sure the down valve solenoid is receiving the proper voltage and is functioning correctly.

If the solenoid is functioning correctly and the platform will not lower, use a fork truck to prevent the platform from falling when system pressure is released. Carefully insert the forks beneath the platform and raise the forks until the fork truck is supporting the platform or place block under platform.

⚠ DANGER Do not continue to raise the forks after they contact the bottom of the platform or the machine may be damaged. Other secure blocking may be used to prevent the platform from falling when system pressure is released.

- Carefully and slowly loosen the connection from the cylinder to the pump, on the pump side, as shown in diagram. The fluid in the hose will be pressurized and will leak.
- Use a clean container to catch fluid from the line as the fitting is loosened. Use an oil absorbent to clean any spills. Caught, clean fluid can be reused.

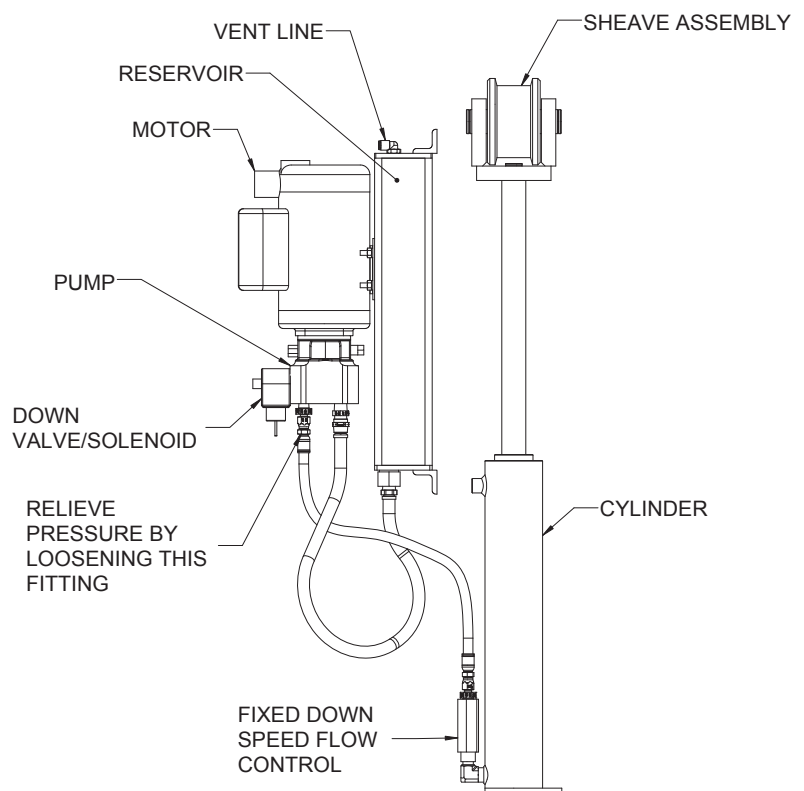

6.3 Cleaning the Down Valve



WARNING

Remove the load and relieve hydraulic system pressure (See Relieving Hydraulic System Pressure in the Maintenance section):

1. Remove the solenoid by loosening and removing the nut. Inspect the solenoid for debris or damage.
2. Remove the valve plunger and inspect the plunger and valve for damage or debris.
3. Clean the valve plunger with solvent.
4. Replace the valve plunger, solenoid and nut. The nut should be tightened to 40 in-lbs.

6.4 Replacing Hydraulic Fluid



DANGER

High pressure fluids can penetrate skin and cause severe injury or death. Always relieve hydraulic system pressure before performing maintenance or repair of the hydraulic system. See Relieving Hydraulic System Pressure section.

A container capable of holding approximately one gallon of hydraulic fluid is required.

To replace the hydraulic fluid:

1. Lower platform to the fully lowered position. Continue to hold the down button for five to ten seconds after the platform stops lowering to relieve hydraulic pressure.
2. Disconnect and lock out electrical power.
3. Disconnect the hose fitting shown in the diagram. Direct the open end of the hose into the container and allow the reservoir to empty.
4. Disconnect the suction filter assembly.
5. Clean the suction filter screen and magnet.
6. Replace the suction filter assembly. Ensure o-ring seal is not damaged.
7. Reconnect the hose fitting to the pump.
8. Refill reservoir with clean hydraulic fluid. **See Hydraulic Information Section.**
9. Raise and lower the platform five to six times to force air from the hydraulic system.
10. Lower the platform to the fully lowered position and check the fluid level. Refill reservoir as necessary. Fluid level should be approximately 3/4 of an inch from the top of the reservoir when the platform is lowered.

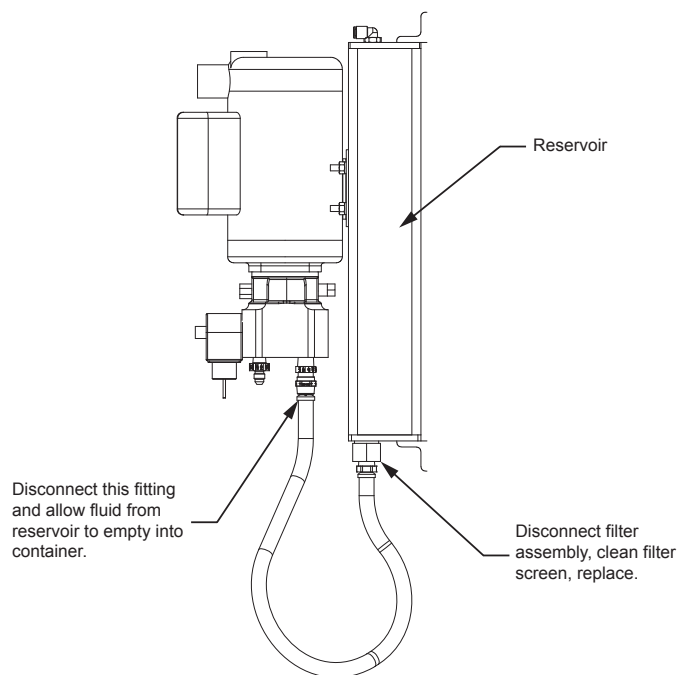

6.5 Ordering Replacement Parts

Presto has carefully chosen the components in your lift to be the best available for the purpose. Replacement parts should be identical to the original equipment. Presto will not be responsible for equipment failures resulting from the use of incorrect replacement parts or from unauthorized modifications of the machine.

Presto will gladly supply you with replacement parts for your Presto lift. With your order, please include the model number and the serial number of the lift. You can find these numbers on the name plate. When you are ordering parts for a cylinder, also include the cylinder number. This is stamped on the base of the cylinder housing.

To order replacement parts, please call the Parts Department. See Warranty & Contact Information section.

- Parts are shipped subject to the following terms:
- FOB factory
- Returns only with the approval of our parts department.
- Payment net 30 days (except parts covered by warranty).
- Freight collect (except parts covered by warranty).
- The warranty for repair parts is 30 days from date of shipment.

Parts replaced under warranty are on a “charge-credit” basis. We will invoice you when we ship the replacement part, then credit you when you return the worn or damaged part, and we verify that it is covered by our warranty. Labor is not covered under warranty for Parts orders.

7. Troubleshooting

Symptom	Possible Cause	What to Look For
Platform will not raise.	Power unit not receiving power.	Check that machine is plugged into a 115/1/60 outlet on a dedicated 20 amp circuit and outlet is powered.
	Up limit switch (if applicable) may be activated or defective.	Verify up limit switch is not activated or malfunctioning.
	The photo eye beam may be obstructed or photo eye may be misaligned.	Verify there are no obstructions of the photo eye beam. If properly aligned the led on the photo eye will be illuminated.
	Push-button/foot controls may not be functioning correctly.	Inspect the control cord, for damage.
	Excessive loading	Verify that load on the platform does not exceed the rated capacity of the machine.
	Hydraulic fluid may be low.	With the platform in the lowered position, the fluid should be approximately 3/4 of an inch from the top of the reservoir.
	The reservoir vent may be blocked.	Verify that the vent cap on the top of the reservoir is not blocked.

Symptom	Possible Cause	What to Look For
Platform will not raise.	The suction filter may be blocked.	Drain the fluid from the reservoir and clean the suction filter. See Replacing Hydraulic Fluid section.
	A vacuum leak in the hydraulic system may be causing cavitation.	Inspect all hydraulic hoses and fittings for loose connections or leaks.
	Push-button/foot controls may not be functioning correctly.	Inspect the control cord, for damage.
	The motor may not be receiving the correct voltage.	Check the supply voltage. The supply voltage must be within $\pm 5\%$ of the rated voltage.
	The down valve solenoid may be energized.	Verify the down valve is not energized.
	The down valve may be stuck open.	Remove and inspect the down valve and solenoid. Clean, reassemble, and reinstall. – See Relieving Hydraulic Pressure section.
Platform will not stay raised	The down valve may be energized.	Verify the down valve is not energized.
	The down valve may be stuck open.	Remove and inspect the down valve and solenoid. Clean, reassemble, and reinstall. See Cleaning Down Valve Section.
	Push-button/foot controls may not be functioning correctly.	Inspect the control cord, for damage.
	Seals in the cylinder may be leaking	Oil on the on the cylinder or excessive fluid in the vent line may indicate leaking seals.
Platform will not lower.	The photo eye beam may be obstructed or photo eye may be misaligned.	Verify there are no obstructions of the photo eye beam. If properly aligned the led on the photo eye will be illuminated.
	Push-button/foot controls may not be functioning correctly.	Inspect the control cord, for damage.
	The down valve may not be energized.	Verify the down valve is being energized.
	The down valve may be blocked from opening.	Remove and inspect the down valve and solenoid. Clean, reassemble, and reinstall. See Cleaning the Down Valve Section.

8. Electrical

Primary Voltage:	115/1/60	Control Voltage:	115/1/60
Motor:	1 HP	3450 RPM	15 Min Duty Rating 17 Full Load Amps

NOTICE

This machine requires a dedicated 20 amp circuit.

8.1 Wiring Schematic

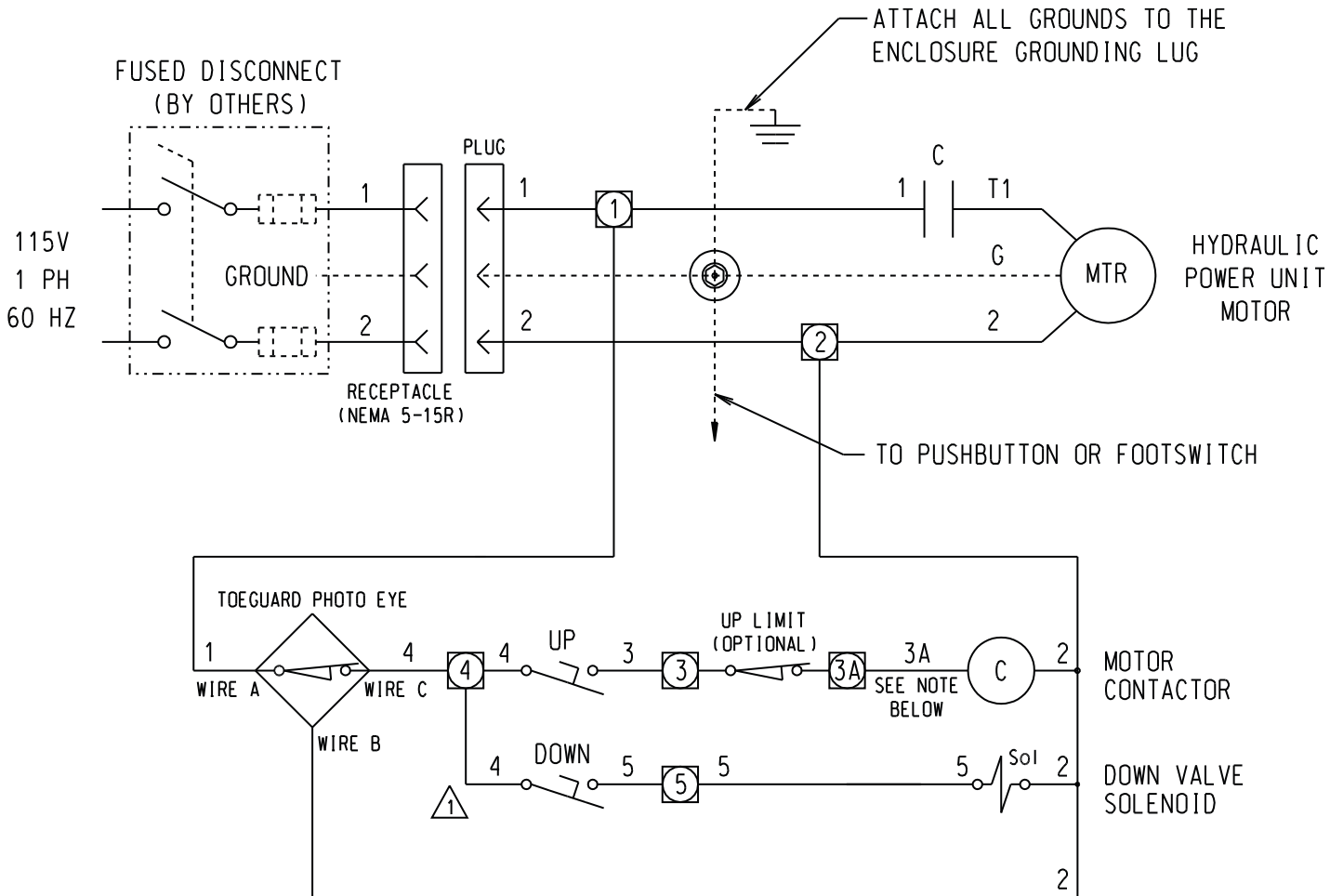

9. Hydraulics

Motor : 1.0 HP

Power: 115/1/60

Pump: 0.85 GPM

Controls: 115/1/60

Standard Hydraulic Fluid: Citgo AW 32 or equivalent

Reservoir Capacity: 0.7 Gallons

9.1 Hydraulic Power Unit

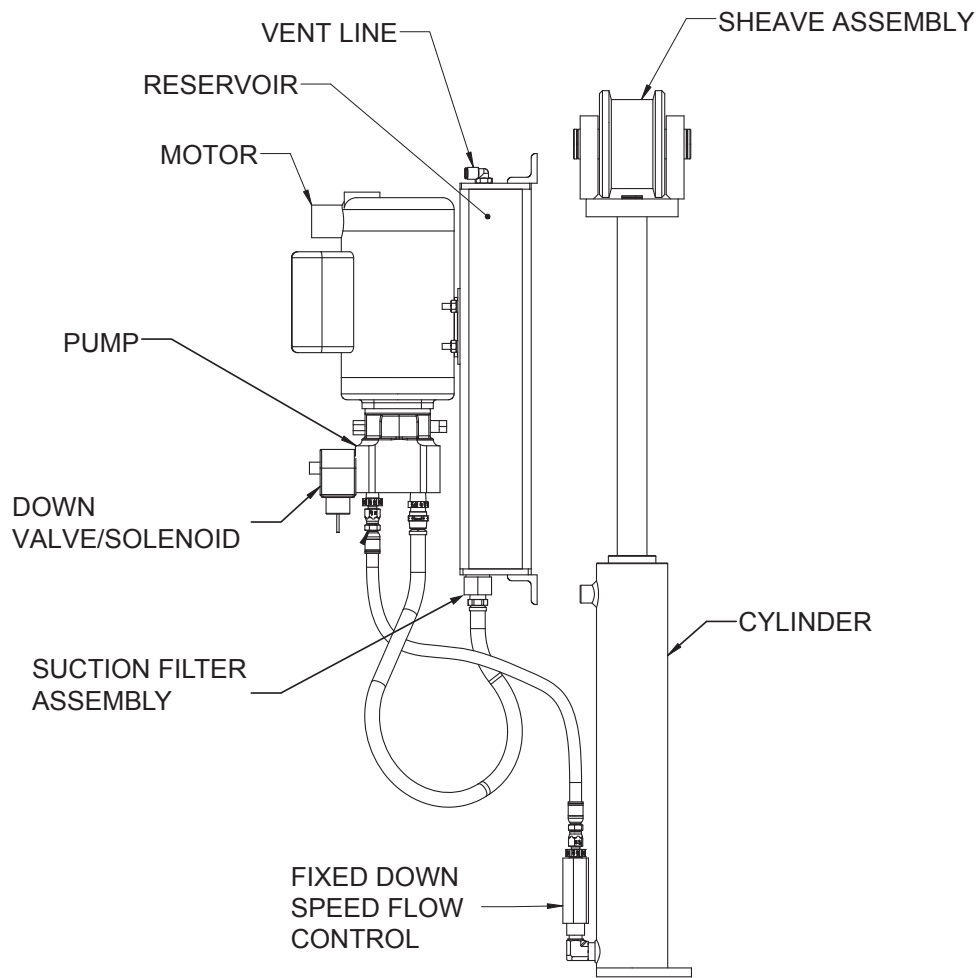

9.2 Hydraulic Schematic

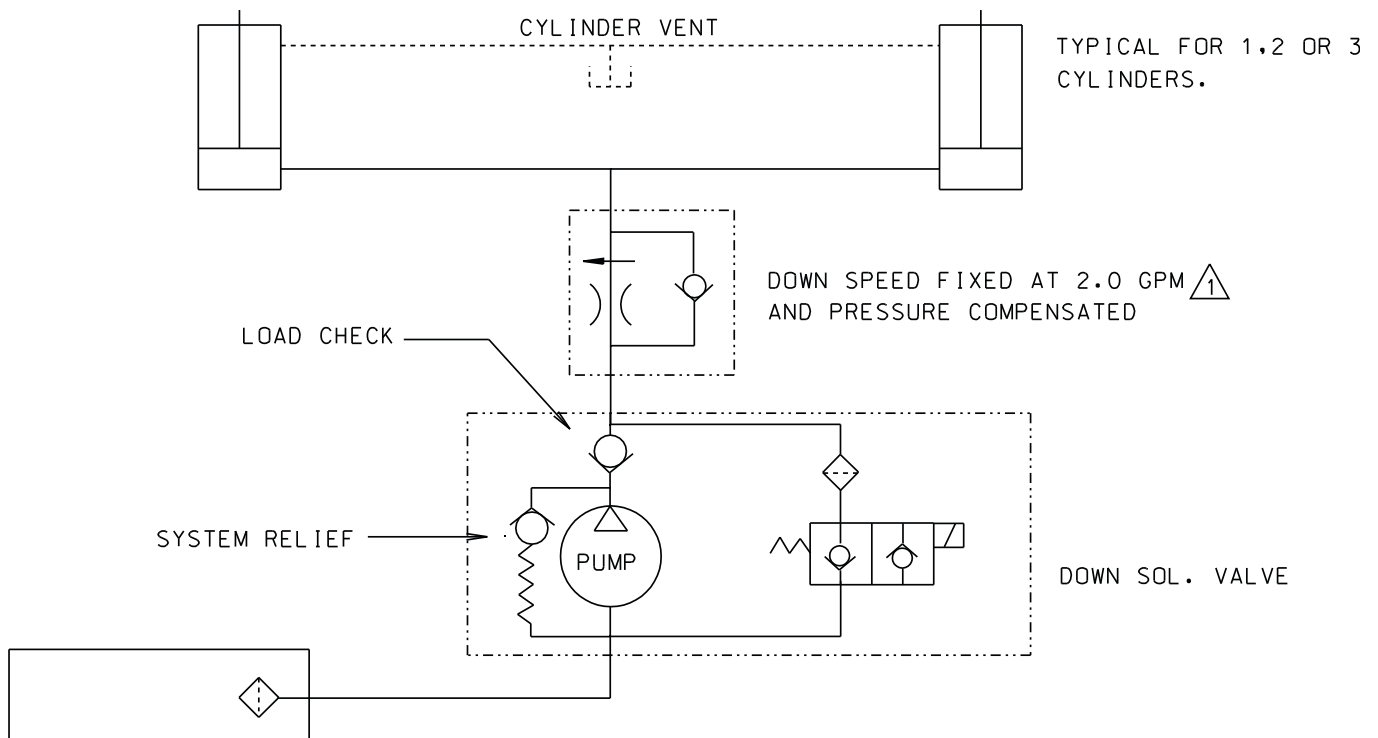

10. Components

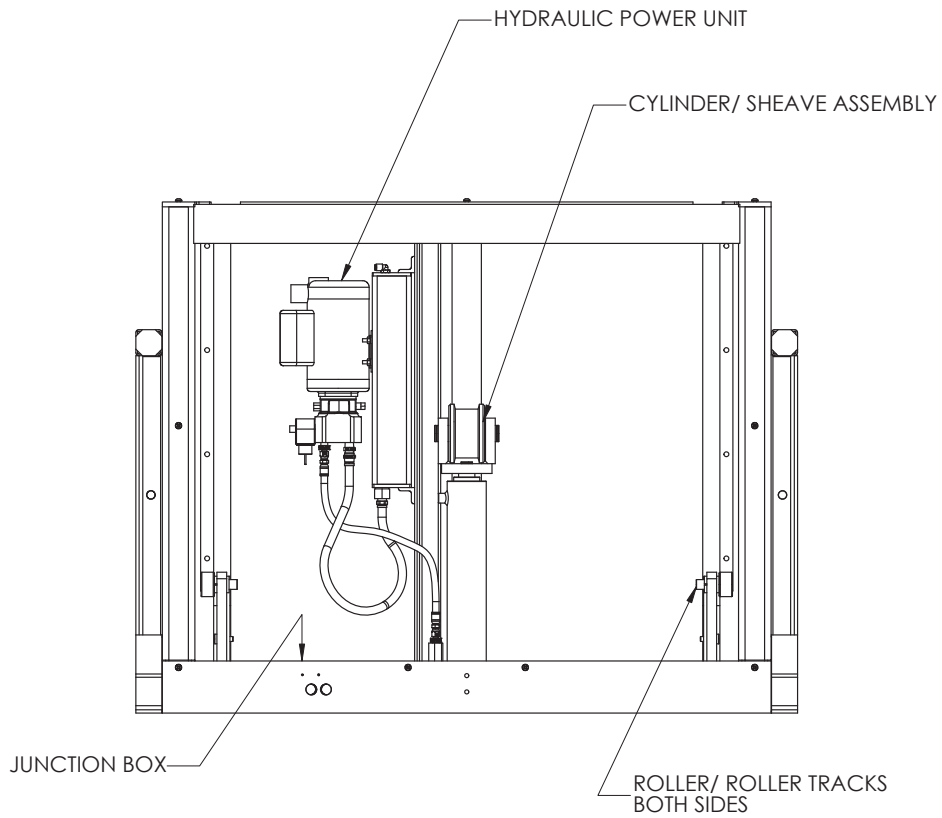
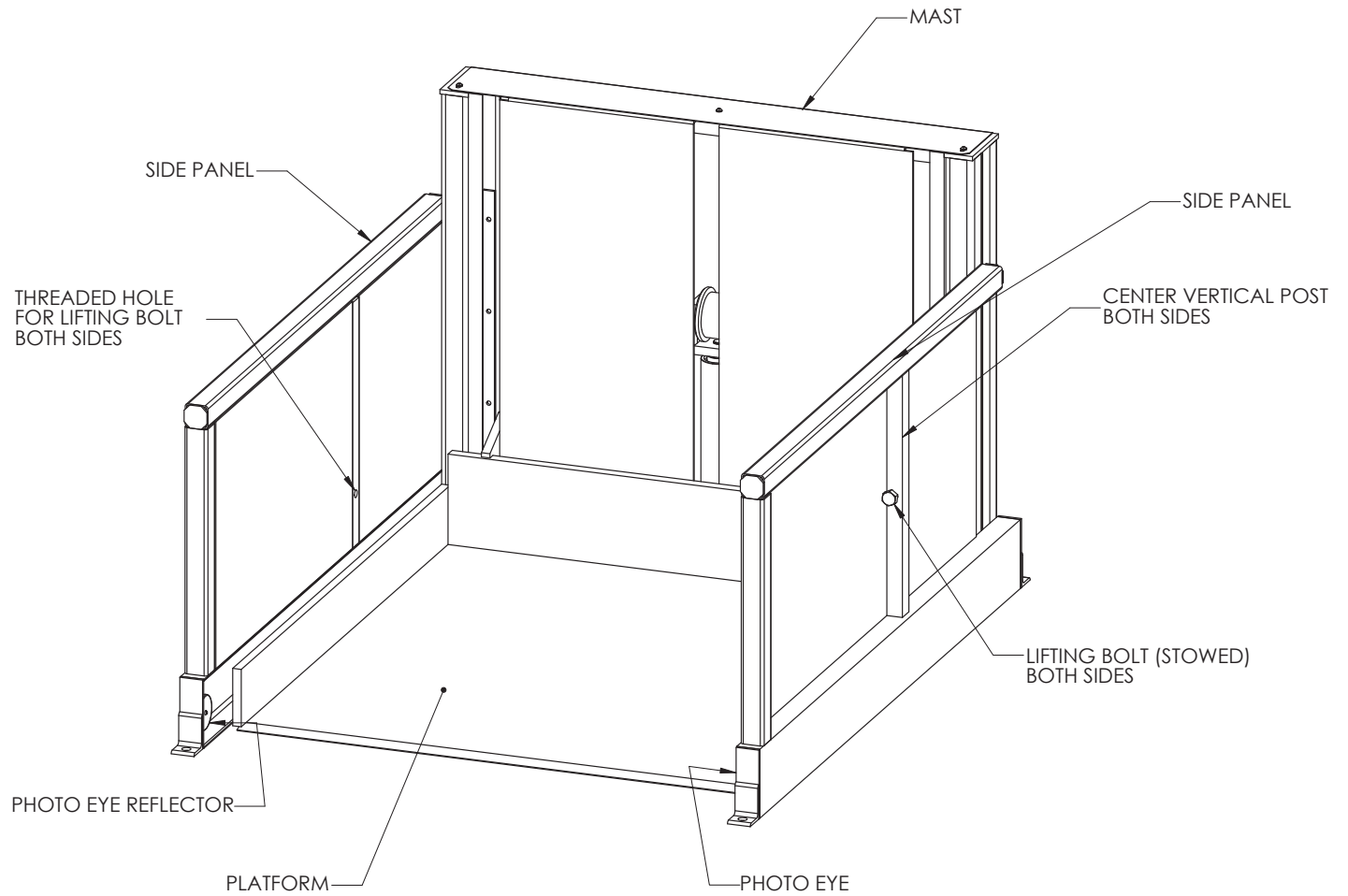

11. Warranty & Contact Information

Presto Lifts Corp. warrants this product to be free from defects in material or workmanship for the duration of the warranty period. Warranty periods vary and begin on the date of shipment. For specific warranty information, contact Presto Lifts with the machine's serial number.

Any claim for breach of this warranty must be received in writing by Presto within the warranty period. Warranties shall not cover failure or defective operation, caused by misuse, misapplication, negligence or accident, exceeding recommended capacities, or any alteration or repair of the item purchased which has not been authorized by Presto. Except as set forth herein, Presto makes no other warranties, express or implied, including THE WARRANTIES OF MERCHANTABILITY AND OF FITNESS FOR A PARTICULAR PURPOSE, all of which ARE HEREBY EXCLUDED.

Presto meets the labeling requirements of California's Proposition 65. Presto makes no warranty or representation with respect to the compliance of any product with other State or local safety or product standard codes and any failure to comply with such codes shall not be considered a defect of material or workmanship under this warranty. Presto shall not be liable for any direct or consequential damages arising out of such non-compliance.

Presto's obligations under any warranty or for any other damages which may arise under any sale, agreement, or contract, are limited to the replacement or repair of defective components at its factory or another location at Presto's discretion. This is buyer's sole remedy under any such warranty, sale, agreement, or contract. Presto will not be liable for consequential, incidental, exemplary, or punitive damages of any kind resulting from a breach of any warranty that it has provided or for breach of any term of any sale, agreement, or contract. Any warranty may be altered only in writing by Presto.



Presto Lifts Inc.
50 Commerce Way, Norton, MA 02766
Phone: 800.343.9322
Fax: 888.788.6496
www.PrestoLifts.com
Email: service@prestolifts.com