

XBP & WBP Series Scissor Lifts

Installation, Operation and Service Manual

Model Number _____

Serial # _____

Date placed in service _____

**IMPORTANT: READ CAREFULLY
BEFORE INSTALLING OR OPERATING LIFT**

Part orders are subject to a \$50 minimum charge.





**This label (part # 10095524)
is required by California law.
For more information visit
www.P65Warnings.ca.gov.**

CONTENTS

SECTION 1:	
Introduction.....	4
Responsibility of Owners and Users.....	5
SECTION 2:	
Safety	6-7
SECTION 3:	
Installation	7-8
A. Uncrating and Inspection	
B. Installing	
C. Electricals	
D. Hydraulics	
E. Testing the Lift with No Load	
SECTION 4:	
Operation	8
A. Method of Operation	
B. Operating Instructions	
SECTION 5:	
Battery Maintenance.....	9
A. Preparing to Charge a Battery	
B. Locating the Charger	
C. Precautions for Grounding an AC Power Cord Connection	
D. Battery Charger Connection Precautions	
SECTION 5:	
Maintenance.....	9-10
A. Routine Maintenance	
B. Troubleshooting Maintenance	
SECTION 7:	
Service	10-11
A. Replacing Cylinder Seals	
B. Replacing Leg Rollers	
SECTION 8:	
Troubleshooting.....	12

LIST OF FIGURES :

XBP and WBP Product Illustration (Figure 1)	13
Recommended Spare Parts List	14
Electrical Schematic for 12 Volt DC XBP and WBP (Figure 2).....	15
Hydraulic Pump (Figure 3)	16
Hydraulic ARR XBP 24-10/15 (Figure 4)	17
Hydraulic Schematic for XBP 36-10/15 (Figure 5).....	18
Electrical ARR for XBP 24/36 (Figure 6).....	19
ACP PORTABLE KIT CASTER/WP FOR XBP 24 (Figure 7)	20
Labels and Locations (Figure 8)	21
RESTOCKING POLICY	22
RETURN MATERIALS AUTHORIZATION (RMA) PROCEDURES	23
ORDERING REPLACEMENT PARTS	24
WARRANTY	25

SECTION 1

INTRODUCTION

This manual attempts to provide all of the information necessary for the safe and proper installation, operation and maintenance of Presto Lifts Inc.'s XBP & WBP DC Electric Scissor Lifts. It is important that all personnel involved with the installation, maintenance or operator of the scissor lift read this manual. Where unique situations arise, that are not covered in this manual call Presto Lifts for further instructions. Additional manuals are available upon request or on our web site at www.prestolifts.com.

The scissor lift has a nameplate that provides the load capacity ratings, serial number and model identifications. Please refer to these numbers when ordering parts or requesting further information.

The Presto Lifts XBP & WBP DC Electric Scissor Lifts are designed for lifting, lowering and positioning a variety of loads. WHERE UNIQUE SITUATIONS ARISE, THAT ARE NOT COVERED IN THIS MANUAL, CALL PRESTO LIFTS FOR FURTHER INSTRUCTIONS.

The XBP & WBP DC Electric Scissor Lifts is designed for inplant/nonhazardous location use only. These units are not for personnel lifting.

Responsibility of Owners and Users

Inspection and Maintenance

The device shall be inspected and maintained in proper working order in accordance with Presto's owner's manual.

Removal from Service

Any device not in safe operating condition such as, but not limited to, excessive leakage, missing rollers, pins, or fasteners, any bent or cracked structural members, cut or frayed electric, hydraulic, or pneumatic lines, damaged or malfunctioning controls or safety devices, etc. shall be removed from service until it is repaired to the original manufacturer's standards.

Deflection

It is the responsibility of the user/purchaser to advise the manufacturer where deflection may be critical to the application.

Repairs

All repairs shall be made by qualified personnel in conformance with Presto's instructions.

Operators

Only trained personnel and authorized personnel shall be permitted to operate the equipment.

Before Operation

Before using the device, the operator shall have:

- Read and/or had explained, and understood, the manufacturer's operating instructions and safety rules.
- Inspected the device for proper operation and condition. Any suspect item shall be carefully examined and a determination made by a qualified person as to whether it constitutes a hazard. All items not in conformance with Presto's specification shall be corrected before further use of the equipment.

During Operation

The device shall only be used in accordance with this owner's manual.

- Do not overload.
- Ensure that all safety devices are operational and in place.

Modifications or Alterations

Modifications or alterations to any Presto industrial positioning equipment shall be made only with written permission from Presto.

SAFETY ALERT SYMBOLS AND SIGNAL WORDS

The safety of all persons operating, maintaining, repairing, or in the vicinity of this equipment is of paramount concern. This is a powerful machine with moving parts, and is capable of causing personal injury if proper precautions are not taken. Therefore, throughout this manual, certain hazards have been identified which may occur in the use of the machine, and there are appropriate instructions or precautions which should be taken to avoid these hazards. In some cases, there are consequences which may occur if instructions or precautions are not followed. Below are the symbols and signal words along with their definitions referenced from ANSI Z535.4 - Product Safety Signs and Labels.

Safety Alert Symbols

These are the safety alert symbols.. They are used to alert you to potential physical injury hazards. Obey all safety messages that follow this symbol to avoid possible injury or death.



For use with **DANGER** signal word
(Red Background)



For use with **WARNING** signal word
(Orange Background)



For use with **CAUTION** signal word
(Yellow Background)

Signal Words

The meaning of different signal words as defined by ANSI Standard Z535.4 indicates the relative seriousness of the hazardous situation.



(Red Background)

DANGER indicates a hazardous situation which, if not avoided, will result in death or serious injury.



(Orange Background)

WARNING indicates a hazardous situation which, if not avoided, could result in death or serious injury.



(Yellow Background)

CAUTION, used with the safety alert symbol, indicates a hazardous situation which, if not avoided, could result in minor or moderate injury.



(Blue Background)

NOTICE is used to address practices not related to personal injury.



(Green Background)

SAFETY INSTRUCTIONS (or equivalent) signs indicate safety-related instructions or procedures.

SECTION 2

SAFETY

The XBP & WBP DC Electric Scissor Lifts are very powerful lifts capable of doing large amounts of work. They contain scissor legs, that are hydraulically actuated and are capable of causing serious injury or damage if adequate precautions are not taken.

DO NOT INSTALL OR OPERATE THESE LIFTS WITHOUT CAREFULLY READING THIS MANUAL. In order to provide for the safe operation of these scissor lifts, Presto Lifts Inc. has identified certain hazards that may occur during the installation, maintenance and use of these lifts. **For safety reasons the standard XBP & WBP DC Electric Scissor Lifts are designed to be serviced or repaired in the lowered position.** If performed properly, this will greatly reduce the possibility of injury. Lifts with oversize table tops require special handling (See Section 7.B.).

SAFETY INSTRUCTIONS

- Do not work under the table.
- All personnel must stand clear of the lift when the lift is in motion.
- Do not put hands or feet under the lift table.
- Do not stand, sit or climb on the lift.
- Do not use the lift on soft, uneven or unstable surfaces.
- Do not exceed the load capacity.
- Do not place a load on a moving lift.
- Place loads in the center of the table and secure loads properly.
- Do not perform any repair work on lifts if there is a load on the platform or with the table in a raised position.

SECTION 3

INSTALLATION

A. UNCRATING AND INSPECTION:

Upon receipt of the XBP & WBP DC Electric Scissor Lifts, inspect the equipment completely to determine if there is any shipping damage, and that the lift is complete. Presto Lifts Inc. tests and inspects every piece of equipment prior to shipment. If damage is apparent, a freight claim must be filed with the freight company. Do

Not use the lift if there appears to be any damage. With the lift in a collapsed position, check the following:

NOTICE

Lifts with oversize table tops must not be over extended since doing so may disassociate the cylinder base from its socket. (See Section 7.B.).

- Check for signs of damage especially to the electrical and hydraulic components.
- Check all connections for tightness.
- Check for any bent or damaged metal parts.
- Check base frame for flatness.

NOTICE

When moving the lift, do not attempt to pick it up by the table top. The lift should be picked up by its base only.

B: INSTALLING:

Before starting, be sure that the battery is connected. Read all of the instructions prior to starting the lift.

1. Handle Assembly

- a). Portable lifts have the push handles removed for ease of shipping. Handles should be inserted in the holders until they bottom out then tighten set screws on each holder with an Allen wrench.

C. ELECTRICALS:

1. The motors on XBP & WBP DC Electric Scissor Lifts are special intermittent duty motors with high pull up torques. These motors require heavier duty electrical controls than standard motors.

WARNING

Do not attempt to modify or change the electrical circuit. Any alterations will cause damage to the pump and possible physical injury. Only authorized personnel should service the electrical system.

2. For the XBP & WBP DC Electric Scissor Lifts, a battery charger is furnished with a short AC 120 plug. A circuit of 15 amps or larger will suffice to operate the battery charger.

D. HYDRAULICS:

1. Use only hydraulic oil for the lift. The lift has been supplied with Conoco Super Hydraulic 32. When adding fluid, use only the recommended oils.
2. Before using the lift, check the hydraulic oil level and add oil if necessary. Check fittings for tightness.

NOTICE

XBP & WBP DC Electric Scissor Lifts are designed for normal factory environments. Where below freezing conditions may exist, special fluid must be used. Contact Presto Lifts for further information when freezing conditions exist.

WARNING

Do not use automotive hydraulic, brake or transmission fluids. They may damage seals and could pose a serious fire hazard.

E. TESTING THE LIFT WITH NO LOAD:

1. Before testing the lift, clear the area of any loose material. Be sure the lift has no obstruction above it or on any side.
2. Using the controls provided, briefly operate the lift (5-10 seconds). If the lift begins to rise with a humming sound and functions properly, continue to the full upright position.

NOTICE

If the lift does not rise immediately, or there is any operational problem, stop it immediately. Before continuing, check the rotation of the pump and motor and the voltage at motor terminals; again briefly operate the lift. If the lift does not move smoothly with a humming sound, stop and review the procedures on troubleshooting (Section 8).

3. After raising the lift completely, lower the lift. It should move slowly and smoothly with a humming sound. If the lift operates properly, raise and lower the lift and stop at different levels to get a good perspective on the lift's operations and movements.

SECTION 4 OPERATION

A. METHOD OF OPERATION:

Electric

All XBP & WBP DC Electric Scissor Lifts are provided with a special relief valve and are factory preset for the maximum safe capacity of the lift. Activating and holding the up switch will energize the motor. The motor is attached to a positive displacement pump, that draws hydraulic fluid from the reservoir and transfers it under pressure to the cylinder. This forces the piston forward and the scissor legs to separate and raise the platform, releasing the up button will stop the lift. A check valve between the pump and piston holds the table in position. Depressing and holding the down switch will energize a solenoid, that allows the oil from the cylinder to return to the reservoir through a preset flow control. This allows the lift to lower smoothly and at a controlled speed.

NOTICE

Do not attempt to change the setting on the pressure relief valve. Do not maintain the up or down button energized if the lift fails to move or after it has reached its up or down limits. This will cause damage to the pump and controls.

B. OPERATING INSTRUCTIONS:

In order to operate the lift follow these operating procedures.

Read and understand all the instructions before operating. If the lift has modifications or accessories, read and understand their functions.

- 1). Load the lift correctly.

Portable lifts: Place the load on the center of the table top. The load center of gravity must be within 6" of the lift table top center and equally distributed over 80% of the table.

If the load is unstable or may become unstable, fasten it into position.

- 2). Operate the lift.
 - a). To raise the lift, press and hold the up button.
 - b). To lower the lift, press and hold the down button.
 - c). Release the button to stop the lift.
- 3). Wait until the lift has come to a complete stop before unloading the lift.
- 4). Stand clear of lift when operating it in order to avoid injury.



- a). Do not stand, sit or climb onto the lift.
- b). Do not load or unload a moving lift.
- c). If the lift fails to move or exhibits strange movements or sound, stop immediately. Do not operate the lift until it has been checked and repaired.
- d). Obey all warning labels.
- e). Do not exceed maximum rated load.
- f). Maintain load, center of gravity, within 6" of the center of the portable lift.

SECTION 5

BATTERY MAINTENANCE

A. PREPARING TO CHARGE A BATTERY

1. Be sure the area around the lift and the battery is well ventilated while battery is being charged.
2. The battery terminals, connections and wiring connections should be clean and free of corrosion. When cleaning any of these components wear a face shield or other suitable protective eyewear.
3. Carefully follow the manufacturer's recharging instructions that are provided with the battery. If you do not have a copy of these instructions or the instructions for the battery charger they are available free of charge by calling Presto @ 1-800-343-9322.
4. Read, understand and follow all battery and battery charger manufacturer's specific precautions while working with and/or charging batteries.

B. PRECAUTIONS FOR GROUNDING AN AC POWER CORD CONNECTION



Charger should be grounded to reduce risk of electric shock. Charger is equipped with an electric cord having an equipment-grounding conductor and grounding plug. The plug must be plugged into an outlet that is properly installed and grounded in accordance with all local codes and ordinances.



Never alter the AC cord or plug provided. If it will not fit the outlet, have a proper outlet installed by a qualified electrician. Improper connection can result in a risk of an electric shock.

1. To charge the unit, plug the charger into the 110 volt wall outlet. The charger is pre-wired to the battery.
2. Disconnect the charger from the 110 volt wall outlet once the indicators read fully charged.

SECTION 6

MAINTENANCE

Generally, the XBP & WBP DC Electric Scissor Lifts require very little maintenance. Reasonable care will result in excellent trouble-free performance.



Never go under or service lift with a load on the table. Always service the lift in a down position.

A. ROUTINE MAINTENANCE:

All routine maintenance should be performed monthly and can be performed on the standard XBP & WBP DC Electric Scissor Lifts in a lowered height position. Before performing any maintenance, disconnect the battery. Then raise the top over its center position, secure in place and perform the routine listed (1 through 7).

- 1). Check oil level. Add oil if necessary.
- 2). Check rollers for signs of wear. Replace if damaged.
- 3). Check snap ring and shield. Replace if damaged.
- 4). Check hydraulic lines for damage or leaking. Replace if damaged.
- 5). Check for oil spots on the floor. Trace leaks to the proper fitting and tighten.
- 6). Check wiring for damage. Replace immediately if any sign of wear is evident.
- 7). Bearings on these lifts are permanently lubricated and require no servicing. Look for any signs of wear.

B. TROUBLESHOOTING MAINTENANCE:

LIFT WILL NOT MOVE

1. No operational noises:
 - a). Check power switch.
 - b). Check voltage at motor -- motor may have failed.
2. Operational noises:
 - a). Lift may be overloaded or jammed. Check load weight and obstructions.
 - b). Oil shortage -- reservoir low or oil line failure. Repair or replace.
3. Motor overheats:
 - a). Excessive cycle rate (15 per hour max.).
 - b). Low voltage -- check voltage at motor.
 - c). Oil starvation -- check filter in reservoir.

LIFT OPERATING SLOWLY

1. Up cycle:
 - a). Oil starvation -- check filter in reservoir.
 - b). Oil viscosity -- oil is too heavy or too thin.
 - c). Air in cylinder -- cycle lift with no load 2 times and hold down button for 20 seconds after bottoming out on each cycle.
2. Down cycle: (single acting cylinders)
 - a). Pinched hydraulic lines.
 - b). Oil viscosity is too heavy.
3. Lift raises, then slowly lowers without power:
 - a). Leaking hydraulic lines or fittings (check for

- telltale oil spots).
 - b). Check valve in pump -- may not be seating. Requires new pump.
4. Lift will not lower when energized:
 - a). Down solenoid faulty. Check voltage -- may be low or wrong voltage for coil. Check continuity of coil (burned out).
 - b). Pinched hydraulic lines.
 - c). Oil viscosity is too heavy.

SECTION 7

SERVICE

A. REPLACING CYLINDER SEALS:

(Seal kits are listed on page 11)

1. Lower the lift to its lowest position. Then lift the top to its over center position and secure.
2. Disconnect the hydraulic hose from the cylinder and cap the line to prevent hydraulic fluid loss.
3. Loosen the set screws holding the cylinder pin.
4. Remove the cylinder pin.
5. Lift the cylinder out of the lift.

NOTICE

Hold the cylinder securely while removing the pin to prevent it from falling to the floor.

6. Clamp cylinder securely at the base end.
7. Completely collapse cylinder piston.
8. Push gland into the cylinder 1/8" - 3/16".
9. Remove retaining ring.
10. Remove piston rod, piston and gland from cylinder.
11. Remove rod nut, piston and gland.
12. Remove and replace seals and wipers.
13. Assemble piston and gland to piston rod.

14. Assemble rod nut to piston rod and torque to 100 ft./lb.
15. Lubricate piston and seals and install cylinder.
16. Insert retainer ring.
17. Install cylinder and hydraulic lines.
18. Fill reservoir.
19. a). For the lifts serviced in lowered position, lower tabletop completely.
20. Cycle lift 2-3 times adding oil if necessary.
21. Recheck reservoir oil level.

B. REPLACING LEG ROLLERS

(Seal kits are listed on page 14)

1. a). For standard lifts, lower lift to its lowest position. Then lift the top to its over center position and secure.
b). For lifts with an oversize platform it may be necessary to prop up the base frame slightly to allow the platform to hinge over center.
2. Disconnect electrical power.
3. Raise the leg assembly approximately 2" with a pry bar and support with block of wood (2 x 4)
4. Remove retainer clips, shield and rollers.
5. Clean and lubricate axle. Replace with new rollers, shields and clips.
6. Lower the tabletop completely.

SECTION 8

TROUBLESHOOTING

IF LIFT DOES NOT RISE TO FULL HEIGHT — check for leaks or shortage of oil. Maintain the proper oil level. To check oil level, follow these instructions:

- On left hand side, on top of oil well, you will find a hexagon cap screw which is also a dipstick.
- Remove the cap screw and fill oil well with hydraulic oil. Oil should reach notch on dipstick.

IF THE LIFT TENDS TO CREEP DOWNWARD UNDER A LOAD — a speck of dirt may be obstructing the seating of the valve and allowing leakage. To correct, follow these instructions:

- Raise lift to full lifting height and then lower it to lowest point of lift. It may be necessary to do this five or six times. In lowering the lift, lower it in stages, that is, lower the lift six inches to a foot at a time. This will dislodge the dirt and lift will operate properly.

TROUBLESHOOTING MAINTENANCE -- ELECTRIC

Problem	Probable Cause	Service Required
Lift will not move w/ no motor noise	Loss of power Motor failure	Check power switch or battery and charger Check voltage at motor
Lift will not move with motor noise	Overloaded lift Motor	Check load Low voltage at motor -- battery low Oil starvation Check oil reservoir
Motor overheats	Excessive cycling rate	Check cycle rate, 15 cycles per hour maximum Low voltage. Check voltage at motor
Up cycle slow	Oil starvation Oil viscosity Air in cylinder system	Check and fill reservoir Check oil viscosity and replace if necessary Purge system by cycling several times to full extension and retraction
Down cycle slow	Blockage in hydraulic line Oil	Check for pinched lines Oil viscosity too heavy; replace Oil contaminated; replace
Lift raises then lowers slowly	Check valve leaking Down valve leaking Leaking fitting	Remove and clean Remove and clean Check fittings and lines for telltale oil spots

XBP and WBP 1,000 lb. and 1,500 lb. Machines

COMPONENT IDENTIFICATION

ITEM NO.	QTY	PART NUMBER	DESCRIPTION
1		See Standard Parts Chart	Hydraulic Cylinder
2	1	Contact Parts Department	Safety Velocity Fuse
3	1	See Standard Parts Chart	Powerpack - 12 Volt system
4	2	C102PH	Phenolic Rigid Wheel- 5"
5		See Standard Parts Chart	Hydraulic Hoses -- Up and Down
6	1	Contact Parts Department	Battery Charger -- Internally Mounted
7	1	C141C	Gell Cell Battery
8	1	2997783P	Floor Lock
9	2	C101PH5	Phenolic Swivel Caster Assembly - 5"
10	1	80000294	Hand Pendant
11	2	B262RC	Starter Solenoid

Note: Call Parts Department for parts for 2,000 lb. machines.

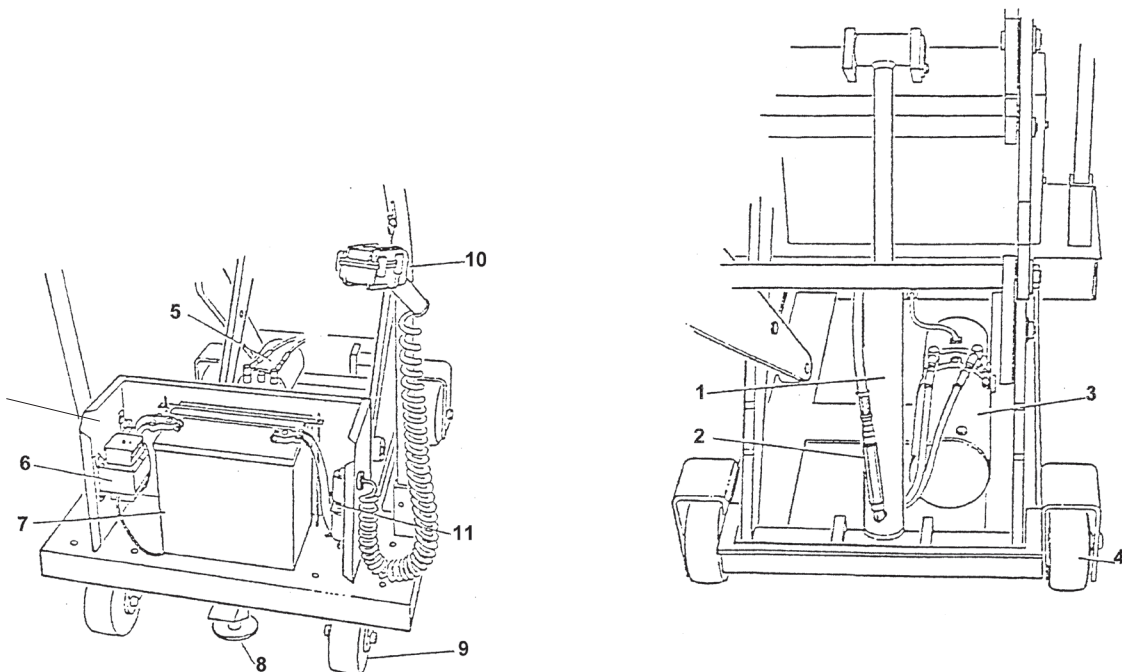

**FIGURE 1:
XBP and WBP SCISSOR LIFTS**

RECOMMENDED SPARE PARTS LISTING
XBP AND WBP 1,000 LB. AND 1,500 LB. MACHINES
(12 VOLT DC POWER ONLY)

Description	Part #	Used On: Model
CYLINDER	1001-171-01 1001-171-02 1001-171-05 1001-171-06	XBP24-15, WBP24-15 XBP36-15, WBP36-15 XBP24-10, WBP24-10 XBP36-10, WBP36-10
HYDRAULIC POWER UNIT	1001-091-01	XBP24-10, XBP24-15, WBP24-10, WBP24-15
HYDRAULIC POWER UNIT	1001-091-03	XBP36-10, XBP36-15 WBP36-10, WBP36-15
GELL CELL BATTERY	C141C	All Units
HAND PENDANT	80000294	All Units with Hand Pendants
SWIVEL CASTER ASSEMBLY (1)	C101PH5	All Units
RIGID PHENOLIC WHEEL	C102PH	All Units
FLOOR LOCK	2997783P	All Units

Note: Call Parts Department for parts for 2,000 lb. machines.

**FIGURE 2:
ELECTRICAL SCHEMATIC 12 VOLT DC POWER -- XBP and WBP**

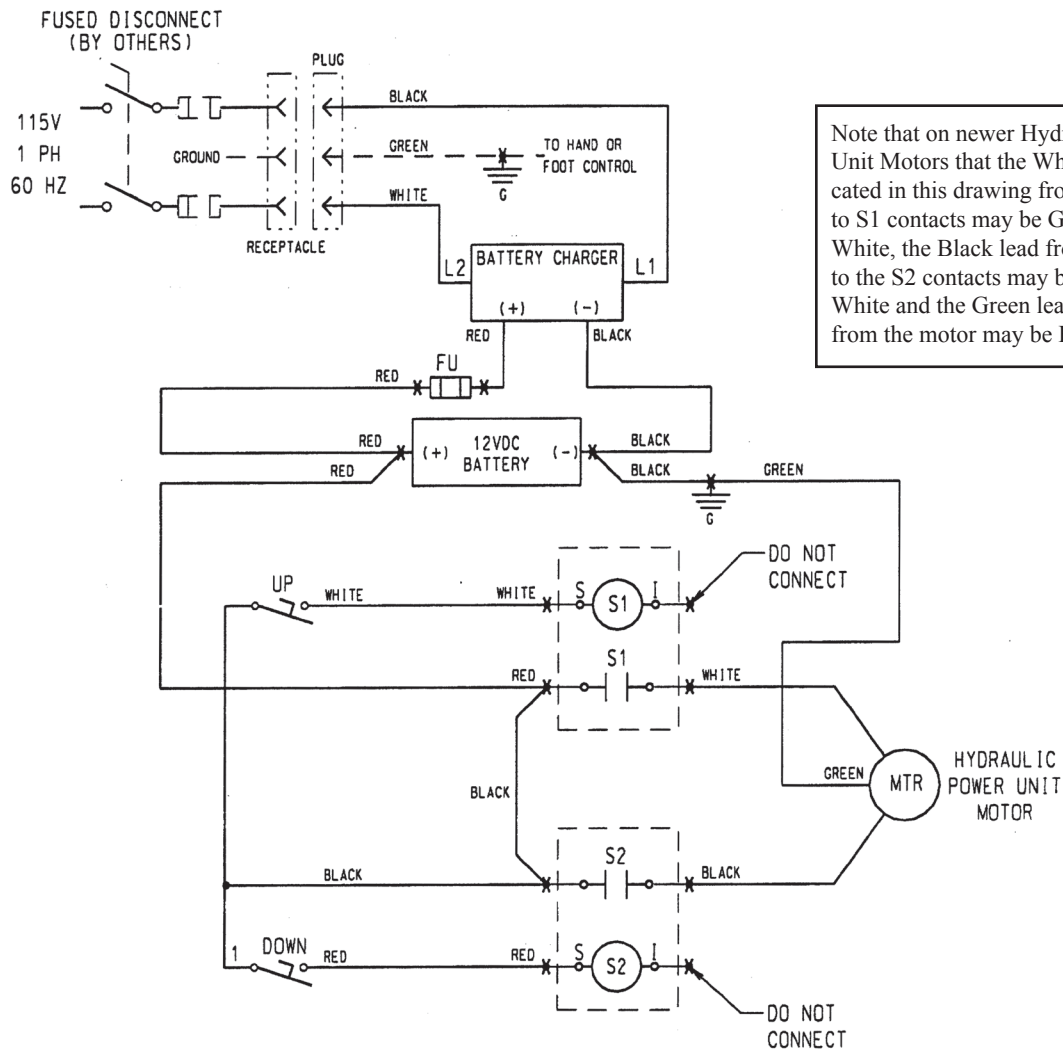

Note that on newer Hydraulic Power Unit Motors that the White lead indicated in this drawing from the motor to S1 contacts may be Green and White, the Black lead from the motor to the S2 contacts may be Blue and White and the Green lead to Ground from the motor may be Black.

X - INDICATES WIRE CONNECTION IN THE HOUSING

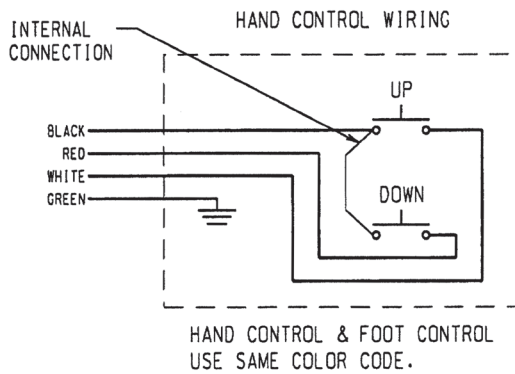

FIGURE 3: HYDRAULIC SCHEMATIC -- ALL MODELS

BI-DIRECTIONAL PUMPS

These pumps are driven by reversible motors and are primarily used to power double-acting cylinders in both directions. Locking checks that hold the load in either direction are standard.

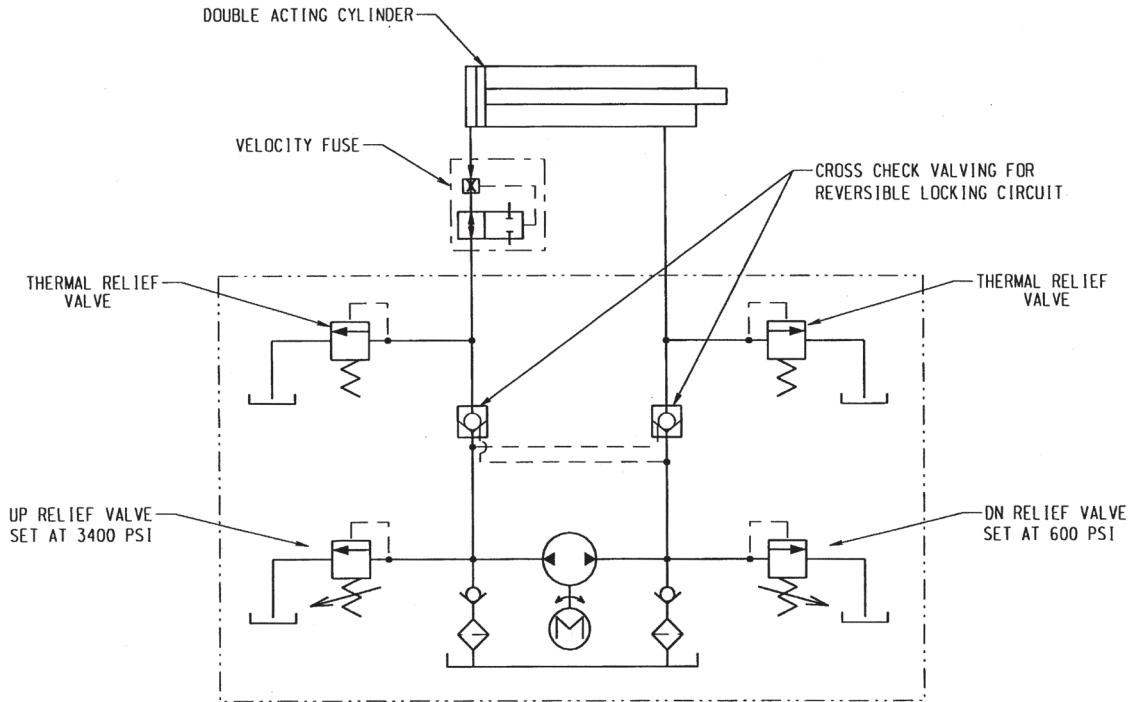

Table 1 – Hydraulic Oil Specifications

If the lift will be used at normal ambient temperatures, Presto Lifts supplies the unit with Conoco Super Hydraulic 32 oil. This may be replaced by any other good quality oil with 150 SSU at 100° F and rust and oxidation inhibitors and anti-wear properties.

If the lift will be used at ambient temperatures below 0°F, use aircraft grade hydraulic oil. Type 15 aircraft hydraulic oil is recommended.

The following are equivalent to CONOCO SUPER HYDRAULICS 32:

TYPE	MANUFACTURER
AW32	CITGO
DTE 24	EXXON/MOBIL
NUTO H32	EXXON/MOBIL
AMOCO AW32	CHEVRON (AMOCO CO.)

CAUTION

It is very important to keep the hydraulic oil free of dirt, dust, metal chips, water, and other contamination. Most of the problems with hydraulic systems are caused by contamination in the oil.

FIGURE 4: HYDRAULIC ARRANGEMENT for XBP24-10 / 15

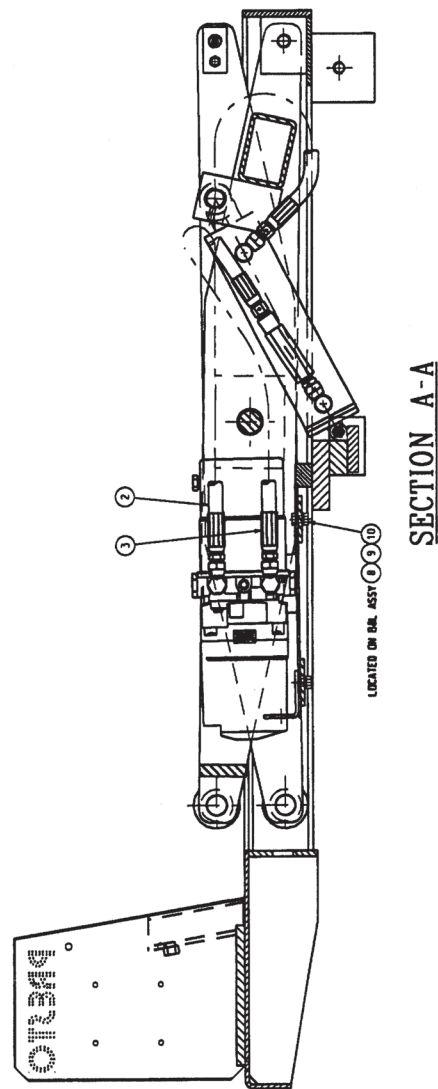
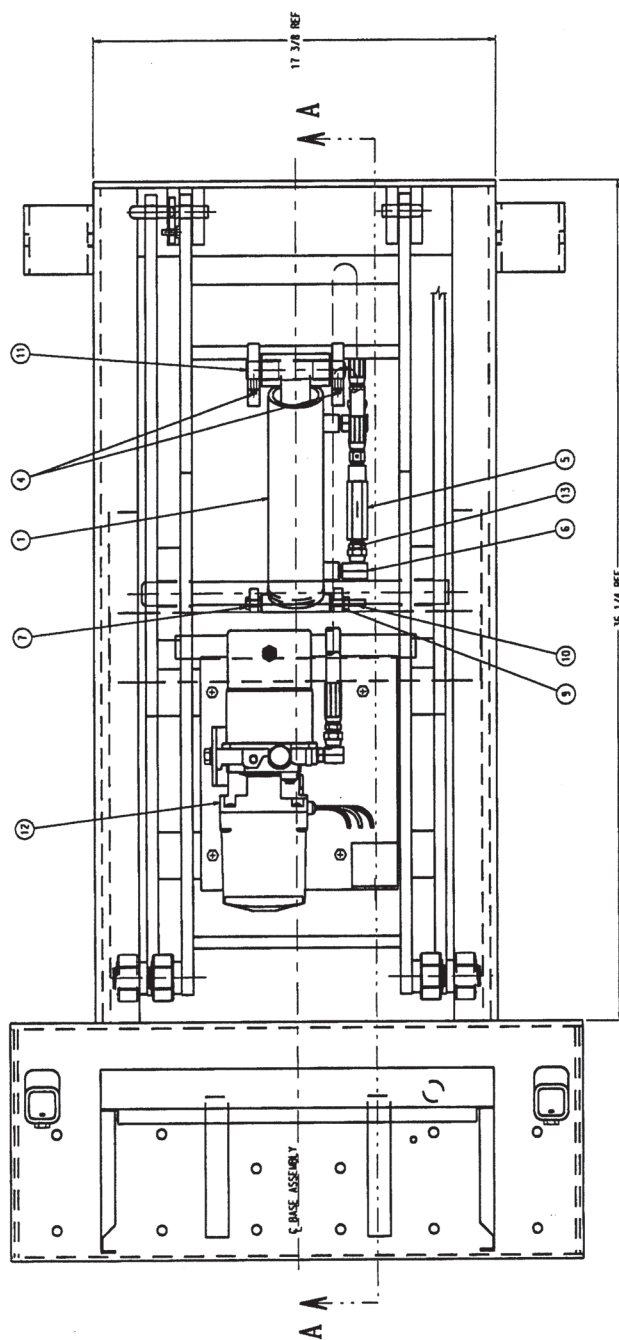

FIGURE 5: HYDRAULIC ARRANGEMENT for XBP36-10 / 15

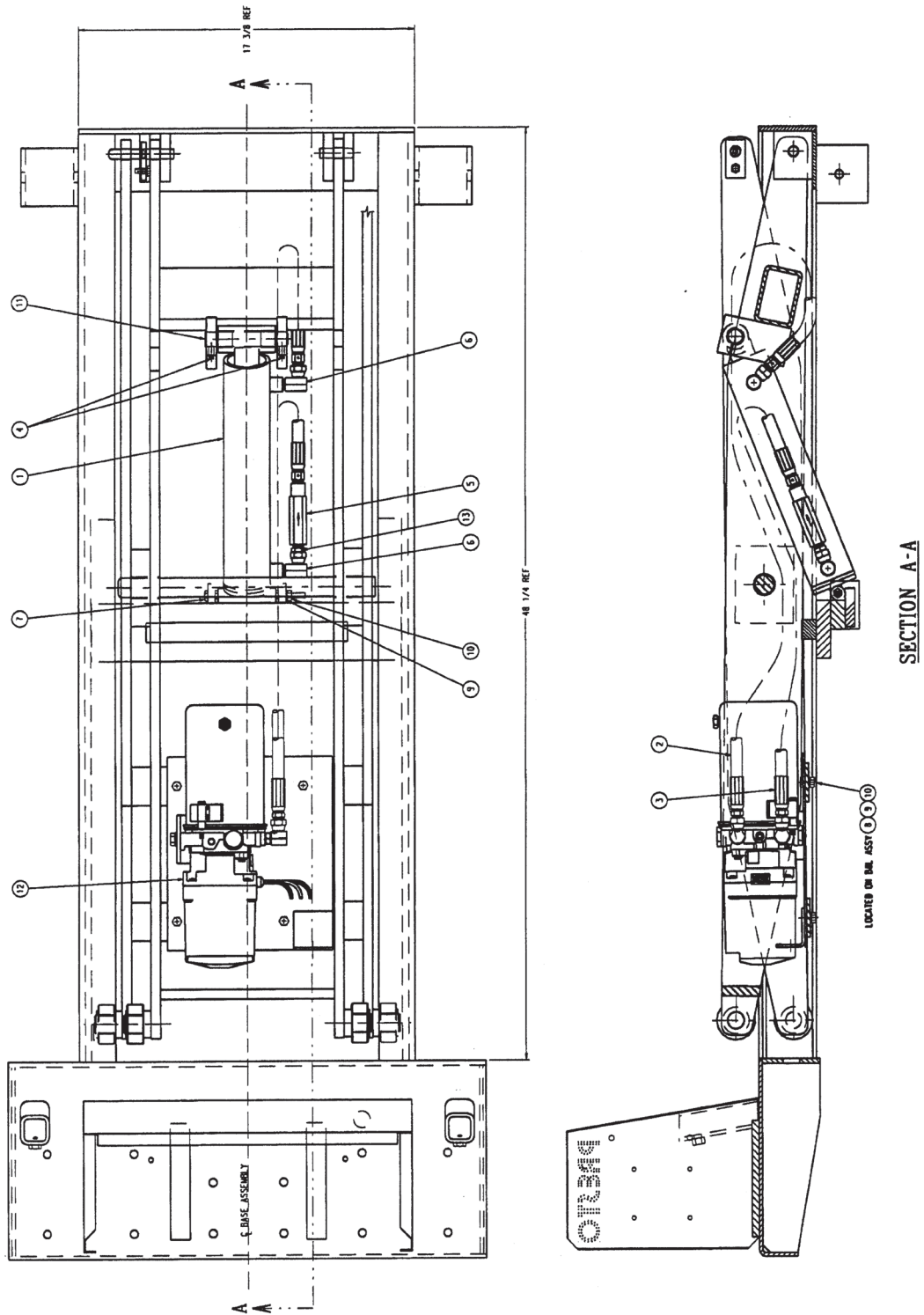

FIGURE 6: ELECTRICAL ARRANGEMENT for XBP24/36

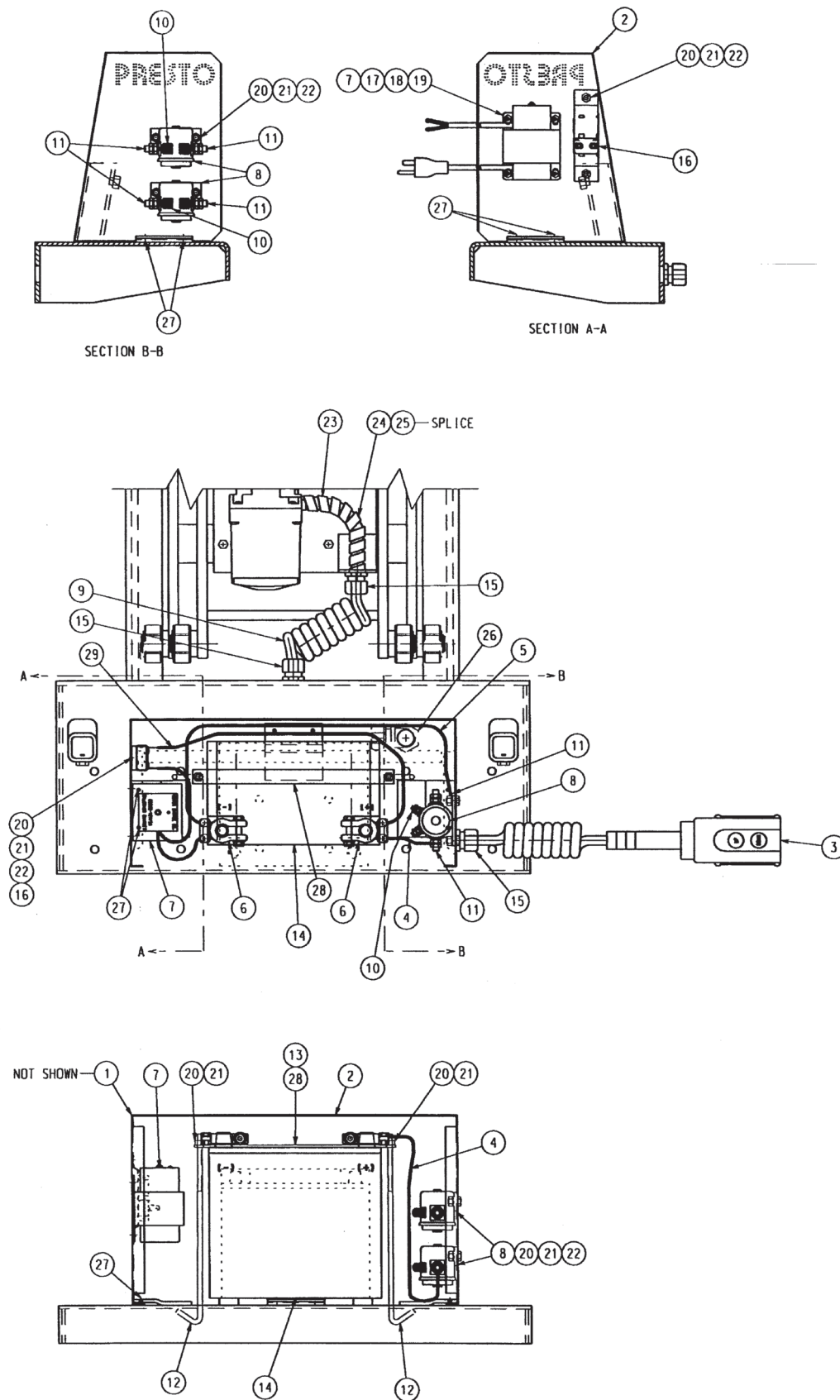
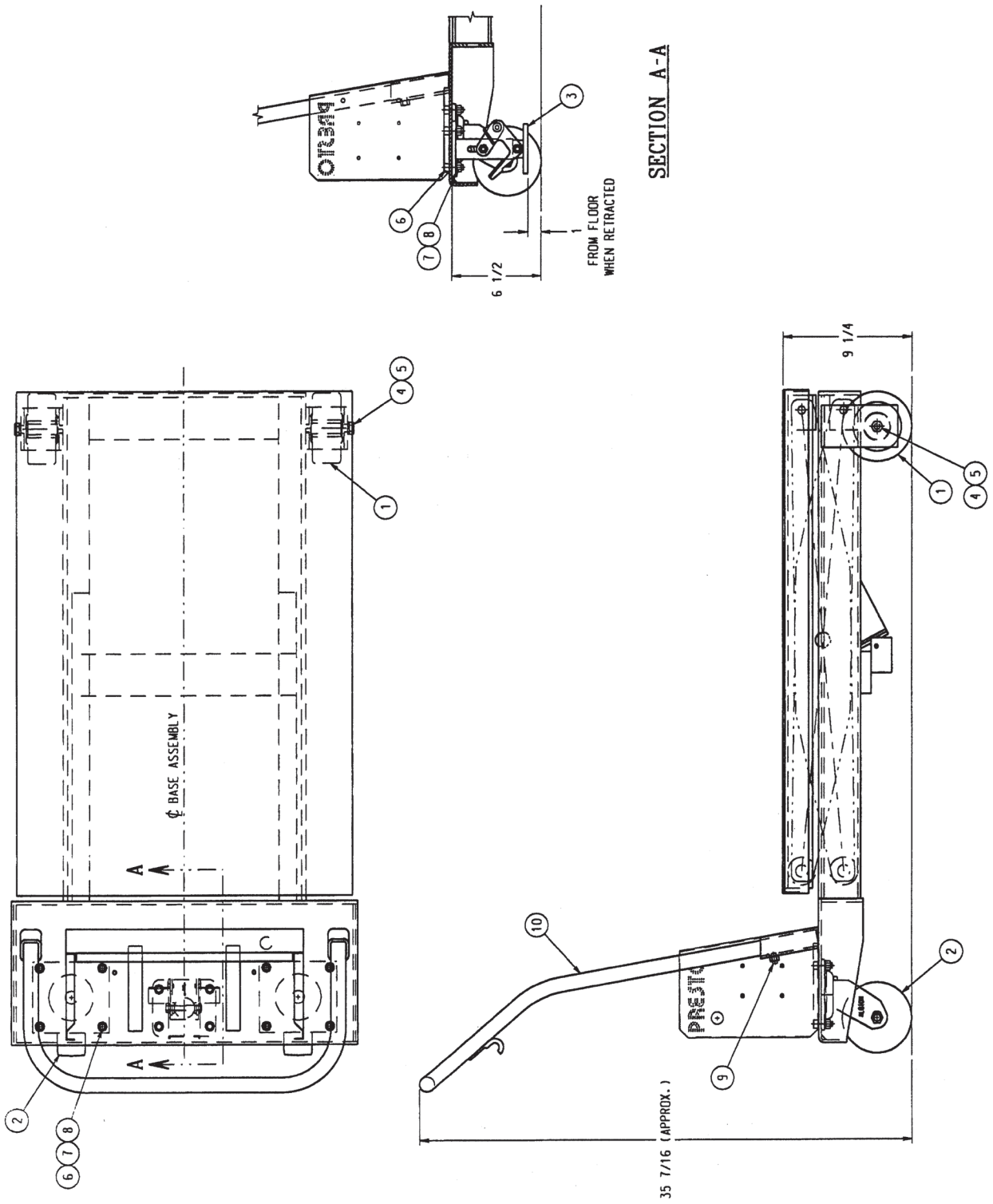

FIGURE 7: ACP PORTABLE KIT CASTER / WP for XBP24



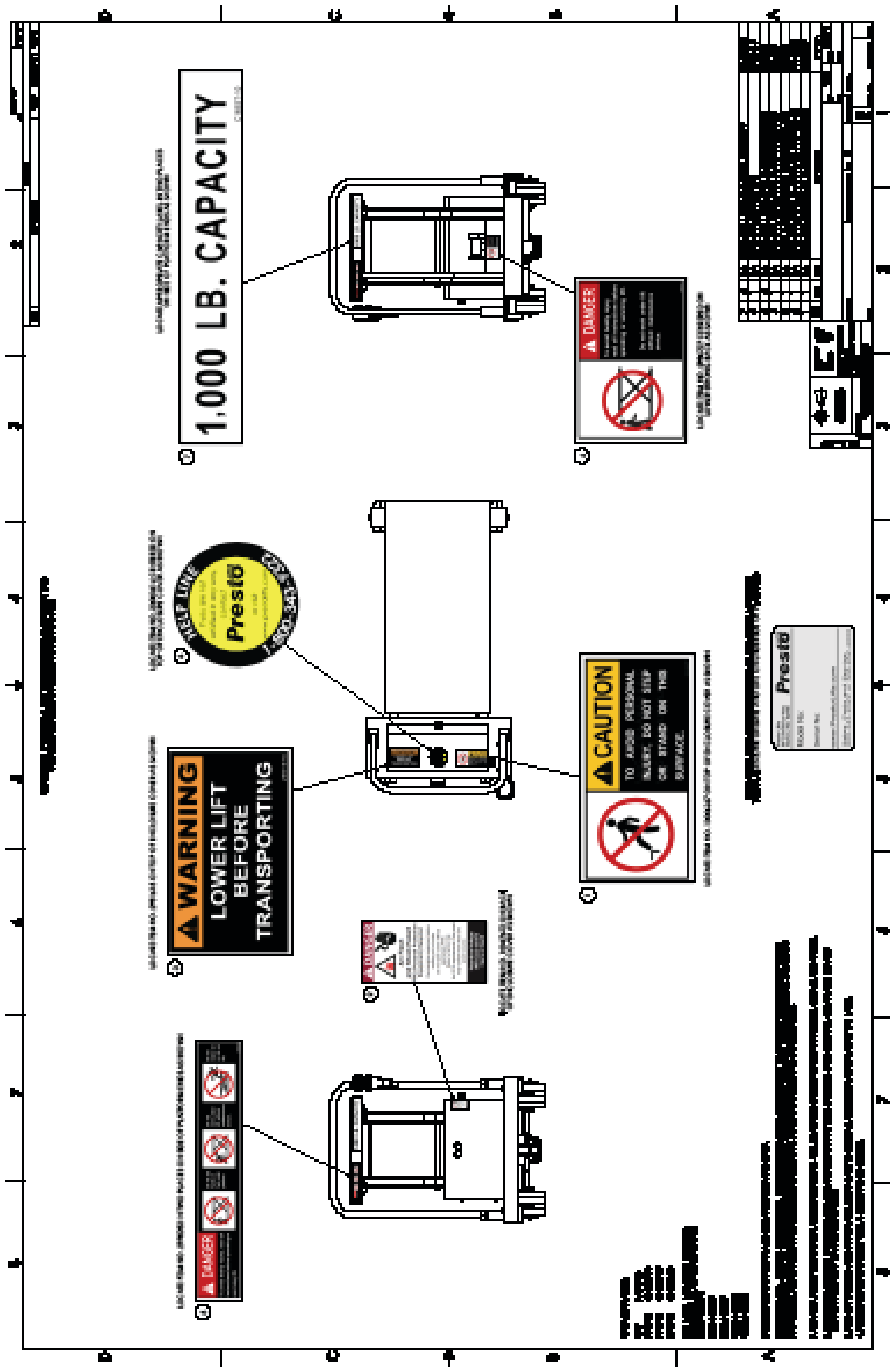

Figure 8: Labels and Locations

PARTS

Standard parts may be returned with a 20% restocking fee. Modified or custom-engineered parts are not returnable. Unfortunately, due to potentially concealed damage, all sales of electrical assemblies are final.

QUALITY ISSUES

Should you feel there is a quality problem, please contact the seller to ask questions and gather information on how to rectify the issue. Presto Lift Inc. reserves the right to determine potential credits, as a result of factory defects, based on its inspection of the merchandise.

GENERAL

All products shipped from our factory have passed Quality Assurance inspection and testing. The carrier of choice has signed for, and accepted the product in new working condition. The customer should inspect to ensure it is not received damaged, has no concealed damage or is not incomplete. Parts orders are determined to be complete based upon Presto Lift, Inc. inspection sheets and carrier shipping weights.

RETURN MATERIALS AUTHORIZATION POLICY

Presto Lifts provides the Return Materials Authorization (RMA) Policy, for specific models, as a courtesy to our distributors in the event they do not receive what they ordered. If a customer wishes to return a Presto Lifts product, please contact the Customer Service Department and request an RMA number. This request must be made on or before the fifteenth calendar day following the date of Presto Lifts' invoice for the merchandise. Not all units are returnable. Quantity orders and special designs cannot be returned under any circumstances. Presto Customer Service reserves the right for final judgment on all product returns.

The RMA number must appear on the outside of any packaging material for a return to be accepted and processed by Presto Lifts. Customers shipping returns from the Continental US, Canada, or Mexico have thirty (30) days from date of RMA issue to have the product arrive at Presto Lifts' facility. All merchandise must arrive Free on Board at Presto Lifts' facility or the shipment will be refused and returned to the sender. All credits are issued less restocking and refurbishing charges, regardless if the merchandise was damaged in transit.

Return addresses: please refer to your RMA for the address to which your product should be returned.

Presto Lift Inc.
715 Highway 77
Manila, Arkansas 72442

Telephone: 800-343-9322
Fax: 888-788-6496

Ordering Replacement Parts

Presto Lifts has carefully chosen the components in your unit to be the best available for the purpose. Replacement parts should be identical to the original equipment. Presto Lifts will not be responsible for equipment failures resulting from the use of incorrect replacement parts or from unauthorized modifications to the unit.

Presto Lifts can supply all replacement parts for your lift. With your order, please include the model number and the serial number of the unit. You can find these numbers on the name plate. This plate is located within the scissors mechanism.

To order replacement parts, please call the Presto Parts Department. Parts are shipped subject to the following terms:

- FOB factory
- Returns only with the approval of our parts department.
- Credit cards preferred (except parts covered by warranty).
- Freight collect for truck (except parts covered by warranty).
- Freight – prepaid and invoice for small parcel shipments (except parts covered by warranty).
- The warranty for repair parts is 30 days from date of shipment.

Parts replaced under warranty are on a “charge-credit” basis. We will invoice you when we ship the replacement part, then credit you when you return the worn or damaged part, and we verify that it is covered by our warranty. Labor is not covered under warranty for Parts orders.

Presto Parts Department

50 Commerce Way
Norton, MA 02766

Telephone: 800-343-9322

FAX: 888-788-6496

Email: service@PrestoLifts.com

www.PrestoLifts.com

Presto Lifts Limited Warranty Policy

Presto Lifts warrants this product to be free from defects in material or workmanship for the duration of the warranty period. Warranty periods vary and begin on the date of shipment. For specific warranty information, contact Presto Lifts with the machine's serial number.

Any claim for breach of this warranty must be received in writing by Presto Lifts within the warranty period. Warranties shall not cover failure or defective operation, caused by misuse, misapplication, negligence or accident, exceeding recommended capacities, or any alteration or repair of the item purchased which has not been authorized by Presto Lifts. Except as set forth herein, Presto Lifts makes no other warranties, express or implied, including THE WARRANTIES OF MERCHANTABILITY AND OF FITNESS FOR A PARTICULAR PURPOSE, all of which ARE HEREBY EXCLUDED.

Presto Lifts meets the labeling requirements of California's Proposition 65. Presto Lifts makes no warranty or representation with respect to the compliance of any product with other State or local safety or product standard codes and any failure to comply with such codes shall not be considered a defect of material or workmanship under this warranty. Presto Lifts shall not be liable for any direct or consequential damages arising out of such non-compliance.

Presto Lifts' obligations under any warranty or for any other damages which may arise under any sale, agreement, or contract, are limited to the replacement or repair of defective components at its factory or another location at Presto Lifts' discretion. This is buyer's sole remedy under any such warranty, sale, agreement, or contract. Presto Lifts will not be liable for consequential, incidental, exemplary, or punitive damages of any kind resulting from a breach of any warranty that it has provided or for breach of any term of any sale, agreement, or contract. Any warranty may be altered only in writing by Presto Lifts.

All commodities, software, or technology purchased from Presto Lifts are subject to the export and re-export control laws and regulations of the United States, including but not limited to the Export Administration Regulations ("EAR") and Department of the Treasury Office of Foreign Asset Controls ("OFAC") Regulations. Presto Lifts expects all distributors and customers to comply with these laws and regulations. Without limiting the foregoing, the distributor/customer cannot, without proper authorization from the applicable United States Government Agency, export, re-export, or transfer any commodity, software, or technology purchased from Presto Lifts, either directly or indirectly, to any entity, country, or national of any country in breach of such laws and regulations. Furthermore, Presto Lifts expects that the distributor/customer shall indemnify and hold harmless Presto Lifts from and against any claim, proceeding, action, fine, loss, cost and damages arising out of or relating to any noncompliance with export control regulations by distributor/customer, and distributor/customer are expected to compensate Presto Lifts for all losses and expenses resulting thereof, unless such noncompliance was clearly not caused by fault of the distributor/customer.