



Nobelstraat 43  
3846 CE Harderwijk  
The Netherlands

Phone: +31 341 - 436700  
Fax: +31 341 - 436701  
www.qimarox.com  
info@qimarox.com

Ordernumber: QS16xxxx  
Project description: Prorunner mk10  
Customer attribute:  
Serial number: mk10 16xxxxx  
Year of construction: 2016

Customer: Qimarox B.V.  
City: Harderwijk  
Country: The Netherlands  
  
End customer: -  
City: -  
Country: -

Special feature: -  
Power supply: 3~400 - 50Hz PE  
Control voltage: 24VDC  
According to: NEN-EN-IEC 60204-1: 2006

Project start: 1-11-2016  
Project end:  
Last time edited: 1-11-2016  
Version number: Vx.x.x  
Number of pages: 55

Sales example



Nobelstraat 43  
3846 CE Harderwijk  
The Netherlands

Phone: +31 341 - 436700  
Fax: +31 341 - 436701  
www.qimarox.com  
info@qimarox.com

Mounting group:       =A       General

Mounting location:

Sales example

# Table of contents

Higher-level function		Mounting location		Page description	Page	Date	Last time edited	Edited by
=A	General			Cover sheet	1	3-6-2015	3-6-2015	DSP
				Title page	2	1-10-2015	1-10-2015	DSP
				Table of contents	3	1-11-2016	1-11-2016	DSP
				Table of contents	3.1	1-11-2016	1-11-2016	DSP
=K	Column prorrerunner mk10	+KS	Column Standard	Title page	1	1-10-2015	1-10-2015	DSP
		+KS	Column Standard	Layout column Standard	15	12-5-2015	2-6-2015	DSP
		+KS	Column Standard	Field components	500	12-5-2015	1-11-2016	DSP
		+KS	Column Standard	Field components	501	12-5-2015	1-11-2016	DSP
		+KS	Column Standard	Parts list	2000	1-11-2016	1-11-2016	DSP
		+KSE	Column Standard, additional position	Title page	1	1-10-2015	1-10-2015	DSP
		+KSE	Column Standard, additional position	Layout Column Standard, 1 additional	15	12-5-2015	2-6-2015	DSP
		+KSE	Column Standard, additional position	Layout Column Standard, 2 additional	15.1	12-5-2015	2-6-2015	DSP
		+KSE	Column Standard, additional position	Field components	500	12-5-2015	1-11-2016	DSP
		+KSE	Column Standard, additional position	Field components	501	12-5-2015	13-5-2015	DSP
		+KSE	Column Standard, additional position	Parts list	2000	1-11-2016	1-11-2016	DSP
		+KE	Column encoder	Title page	1	1-10-2015	1-10-2015	DSP
		+KE	Column encoder	Layout column Standard	15	12-5-2015	2-6-2015	DSP
		+KE	Column encoder	Field components	500	12-5-2015	1-11-2016	DSP
		+KE	Column encoder	Field components	501	12-5-2015	1-11-2016	DSP
+KE	Column encoder	Parts list	2000	1-11-2016	1-11-2016	DSP		
=D	Carrier	+D	Carrier	Title page	1	1-10-2015	1-10-2015	DSP
		+D	Carrier	Layout Carrier	15	12-5-2015	3-6-2015	DSP
		+D	Carrier	Field components	500	12-5-2015	1-11-2016	DSP
		+D	Carrier	Field components	501	12-5-2015	1-11-2016	DSP
		+D	Carrier	Parts list	2000	1-11-2016	1-11-2016	DSP
=T	Conveyor on carrier	+T	Conveyor	Title page	1	1-10-2015	1-10-2015	DSP
		+T	Conveyor	Layout Transporter roles conveyor	15	12-5-2015	3-6-2015	DSP
		+T	Conveyor	Layout Transporter chain conveyor	15.1	12-5-2015	3-6-2015	DSP
		+T	Conveyor	Field components	501	12-5-2015	1-11-2016	DSP
		+T	Conveyor	Parts list	2000	12-1-2016	12-1-2016	DSP
		+TS	Transporteur + stopklep	Title page	1	1-10-2015	1-10-2015	DSP
		+TS	Transporteur + stopklep	Layout Transporteur + stopklep	15	3-6-2015	3-6-2015	DSP
		+TS	Transporteur + stopklep	Field components	500	3-6-2015	1-11-2016	DSP
		+TS	Transporteur + stopklep	Field components	501	3-6-2015	3-6-2015	DSP
		+TS	Transporteur + stopklep	Parts list	2000	1-11-2016	1-11-2016	DSP
		+TC	Transporteur + centrering	Title page	1	1-10-2015	1-10-2015	DSP
		+TC	Transporteur + centrering	Layout Transporteur + centrering	15	3-6-2015	3-6-2015	DSP

Sales example

# Table of contents

Higher-level function		Mounting location		Page description	Page	Date	Last time edited	Edited by
=T	Conveyor on carrier	+TC	Transporteur + centrering	Field components	500	3-6-2015	1-11-2016	DSP
		+TC	Transporteur + centrering	Field components	501	3-6-2015	3-6-2015	DSP
		+TC	Transporteur + centrering	Parts list	2000	1-11-2016	1-11-2016	DSP
		+TSC	Transporteur + stopklep + centrering	Title page	1	1-10-2015	1-10-2015	DSP
		+TSC	Transporteur + stopklep + centrering	Layout Transporteur stopkep + centr	15	2-6-2015	3-6-2015	DSP
		+TSC	Transporteur + stopklep + centrering	Field components	500	2-6-2015	1-11-2016	DSP
		+TSC	Transporteur + stopklep + centrering	Field components	501	2-6-2015	3-6-2015	DSP
		+TSC	Transporteur + stopklep + centrering	Parts list	2000	1-11-2016	1-11-2016	DSP
		+TS2	Transporteur + 2 stopkleppen	Title page	1	1-10-2015	1-10-2015	DSP
		+TS2	Transporteur + 2 stopkleppen	Layout Transporteur 2 stopkeppen	15	3-6-2015	3-6-2015	DSP
		+TS2	Transporteur + 2 stopkleppen	Field components	500	3-6-2015	1-11-2016	DSP
		+TS2	Transporteur + 2 stopkleppen	Field components	501	3-6-2015	3-6-2015	DSP
		+TS2	Transporteur + 2 stopkleppen	Parts list	2000	1-11-2016	1-11-2016	DSP
		+TSC2	Transporteur + 2 stopkleppen + centrering	Title page	1	1-10-2015	1-10-2015	DSP
		+TSC2	Transporteur + 2 stopkleppen + centrering	Layout Transporteur 2 stopkeppen +	15	2-6-2015	3-6-2015	DSP
		+TSC2	Transporteur + 2 stopkleppen + centrering	Field components	500	2-6-2015	1-11-2016	DSP
		+TSC2	Transporteur + 2 stopkleppen + centrering	Field components	501	2-6-2015	3-6-2015	DSP
		+TSC2	Transporteur + 2 stopkleppen + centrering	Parts list	2000	1-11-2016	1-11-2016	DSP

Sales example



Nobelstraat 43  
3846 CE Harderwijk  
The Netherlands

Phone: +31 341 - 436700  
Fax: +31 341 - 436701  
www.qimarox.com  
info@qimarox.com

Mounting group: =K Column prorranner mk10

Mounting location: +KS Column Standard

Sales example

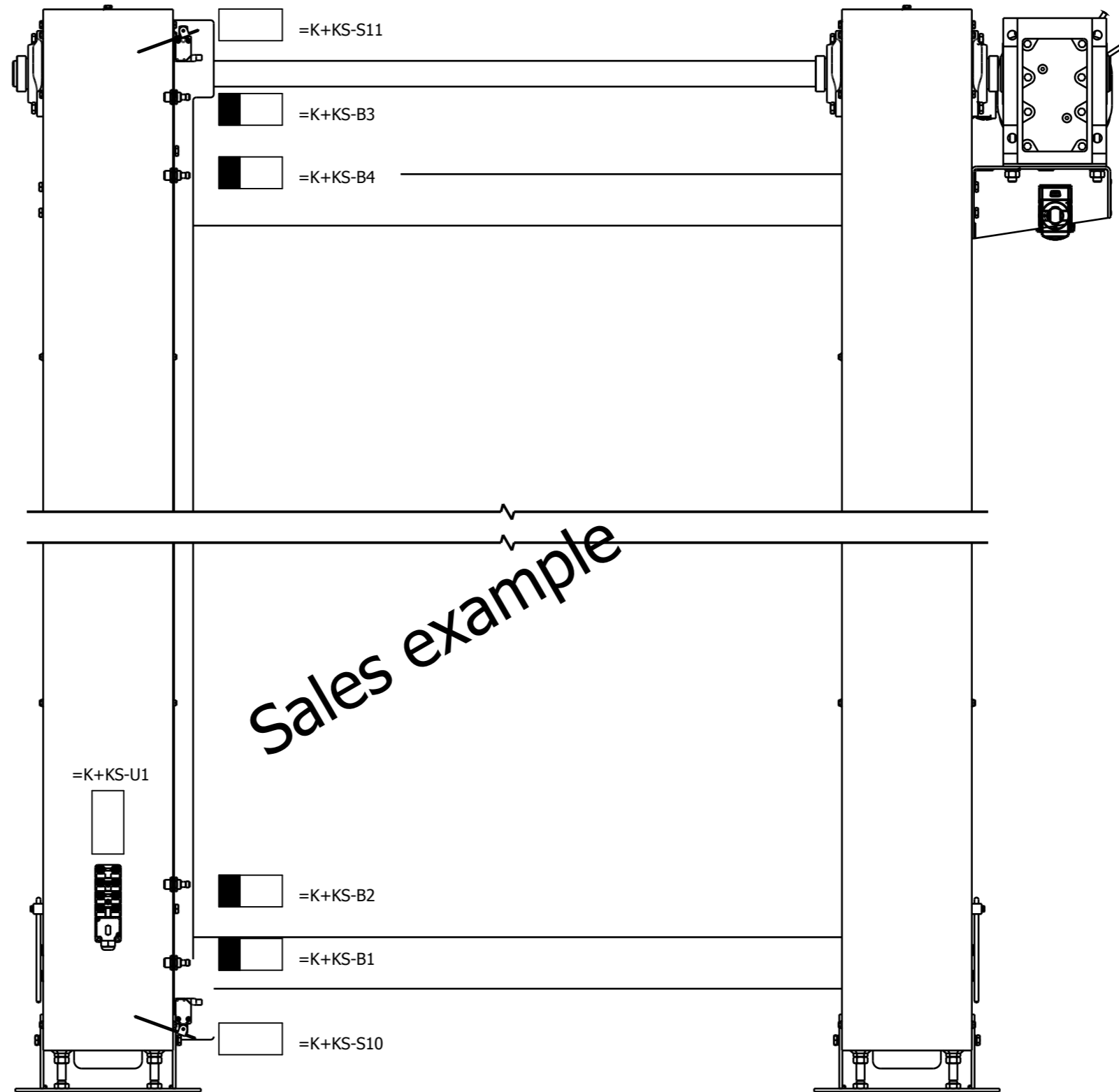

**LEGEND:**

- =K+KS-B1 STOP POSITION BELOW
- =K+KS-B1-W1 1 m PVC-OB 4x0,34mm<sup>2</sup>
- =K+KS-B2 LOW SPEED STOP POSITION BELOW
- =K+KS-B2-W1 1 m PVC-OB 4x0,34mm<sup>2</sup>
- =K+KS-B3 STOP POSITION ABOVE
- =K+KS-B3-W1 5 m PVC-OB 4x0,34mm<sup>2</sup>
- =K+KS-B4 LOW SPEED STOP POSITION ABOVE
- =K+KS-B4-W1 5 m PVC-OB 4x0,34mm<sup>2</sup>
- =K+KS-S10 END-SWITCH BELOW
- =K+KS-S10-W1 1 m PVC-OB 4x0,34mm<sup>2</sup>
- =K+KS-S11 END-SWITCH ABOVE
- =K+KS-S11-W1 5 m PVC-OB 4x0,34mm<sup>2</sup>
  
- =K+KS-U1 CONNECTION UNIT COLUMN PRORUNNER MK10

1

500



Customer  
**Qimarox B.V.**  
 Harderwijk  
 The Netherlands

Type  
 Prorunner mk10

Customer attribute

Ordernumber  
**QS16xxxx**

Serial number  
 mk10 16xxxxx

Description  
 Layout column Standard

Date	2-6-2015	= K
Ed.	DSP	+ KS
		Page 15

Sales example

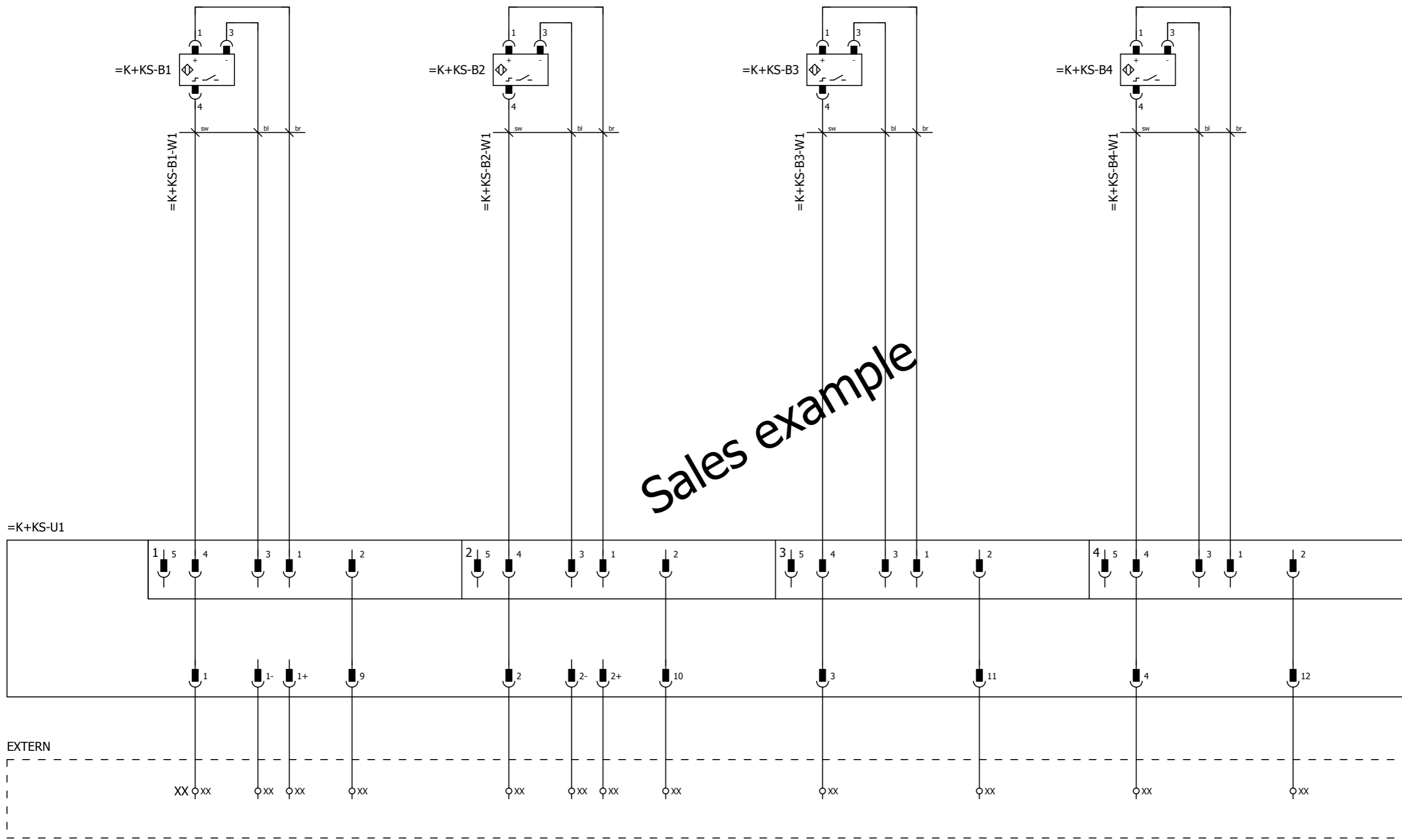

CONNECTION UNIT COLUMN PRORUNNER MK10      STOP POSITION BELOW      SPARE      LOW SPEED STOP POSITION BELOW      SPARE      STOP POSITION ABOVE      SPARE      LOW SPEED STOP POSITION ABOVE      SPARE

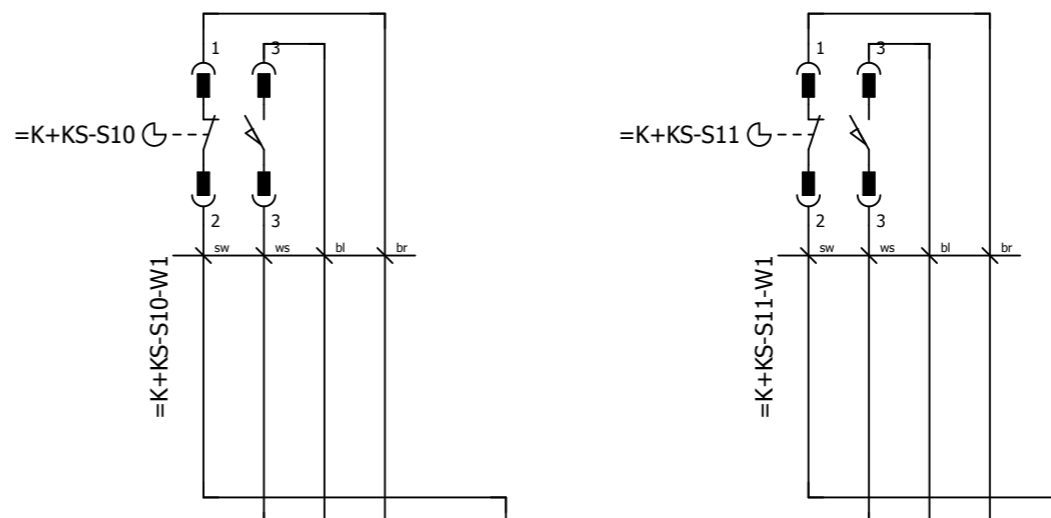

Sales example

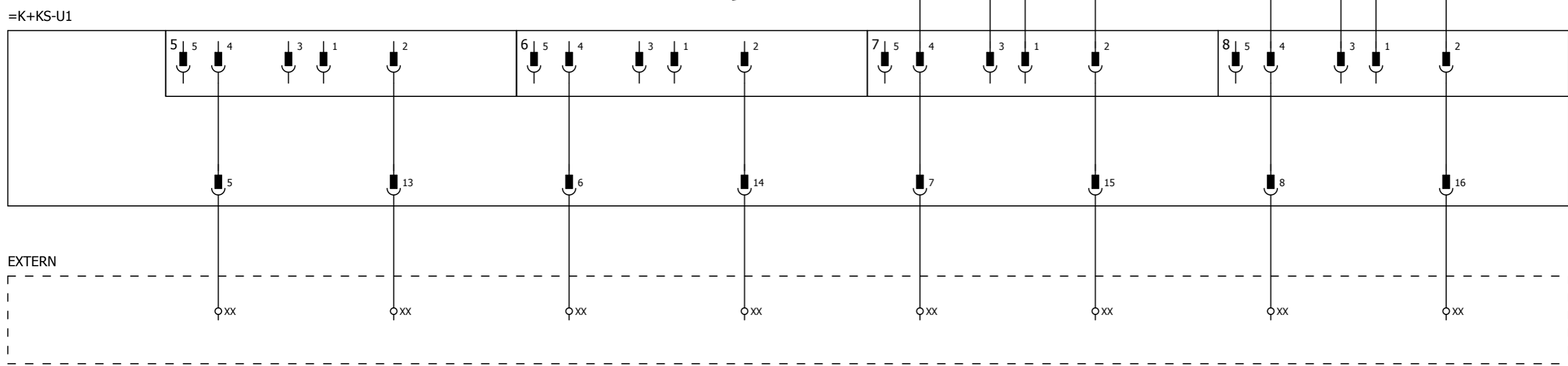

CONNECTION UNIT COLUMN PRORUNNER MK10      SPARE      SPARE      SPARE      SPARE      END-SWITCH BELOW      SPARE      END-SWITCH ABOVE      SPARE



# Parts list

Position	Quantity	Article number	Description
-B1	1	1000932	Inductive proximity sensor
-B1-W1	1	1001601	Prefab cable, PVC, 1 meter, connector M12 male 90°+ M12 female 90°, 4-pole
-B2	1	1000932	Inductive proximity sensor
-B2-W1	1	1001601	Prefab cable, PVC, 1 meter, connector M12 male 90°+ M12 female 90°, 4-pole
-B3	1	1000932	Inductive proximity sensor
-B3-W1	1	1001326	Prefab cable, PVC, 5 meter, connector M12 male 90°+ M12 female 90°, 4-pole
-B4	1	1000932	Inductive proximity sensor
-B4-W1	1	1001326	Prefab cable, PVC, 5 meter, connector M12 male 90°+ M12 female 90°, 4-pole
-S10	1	AE0005524	Limit switch basic contact element, M12 connector
-S10	1	AE0005537	Limit switch lever
-S10	1	AE0005534	Limit switch control head
-S10-W1	1	1001601	Prefab cable, PVC, 1 meter, connector M12 male 90°+ M12 female 90°, 4-pole
-S11	1	AE0005524	Limit switch basic contact element, M12 connector
-S11	1	AE0005537	Limit switch lever
-S11	1	AE0005534	Limit switch control head
-S11-W1	1	1001326	Prefab cable, PVC, 5 meter, connector M12 male 90°+ M12 female 90°, 4-pole
-U1	1	1003309	Connection unit, 8-fold, 5-pole, M12

Sales example



Nobelstraat 43  
3846 CE Harderwijk  
The Netherlands

Phone: +31 341 - 436700  
Fax: +31 341 - 436701  
www.qimarox.com  
info@qimarox.com

Mounting group: =K Column prorumner mk10

Mounting location: +KSE Column Standard, additional position

Sales example

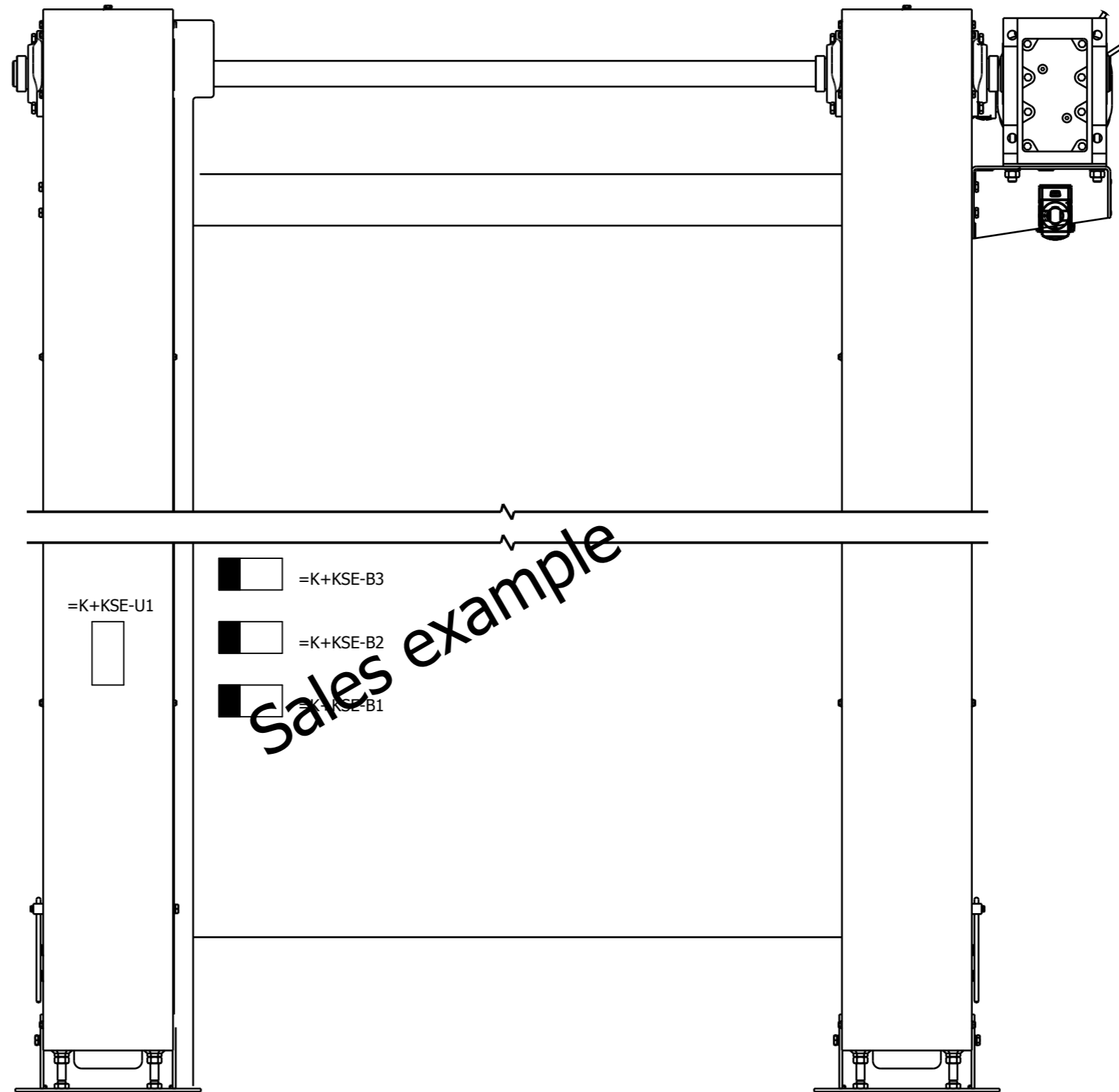

**LEGEND:**

- =K+KSE-B1      LOW SPEED EXTRA POSITION 1 FROM BELOW
- =K+KSE-B1-W1    1 m    PVC-OB 4x0,34mm<sup>2</sup>
- =K+KSE-B2      EXTRA POSITION 1
- =K+KSE-B2-W1    1 m    PVC-OB 4x0,34mm<sup>2</sup>
- =K+KSE-B3      LOW SPEED EXTRA POSITION 1 FROM ABOVE
- =K+KSE-B3-W1    1 m    PVC-OB 4x0,34mm<sup>2</sup>
  
- =K+KSE-U1      CONNECTION UNIT ADDITIONAL POSITION

1

15.1

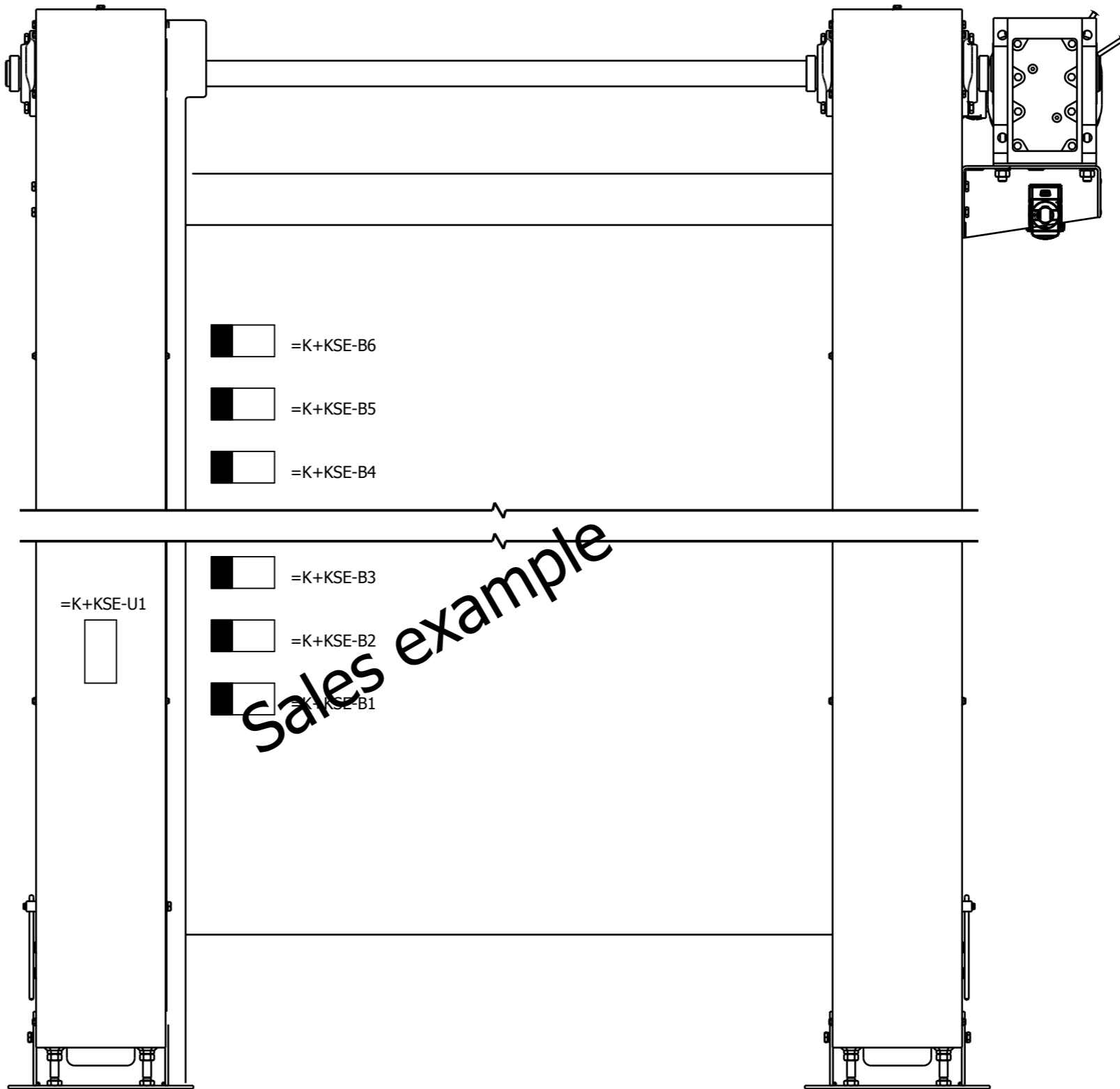

**LEGEND:**

- =K+KSE-B1      LOW SPEED EXTRA POSITION 1 FROM BELOW
- =K+KSE-B1-W1    1 m    PVC-OB 4x0,34mm2
- =K+KSE-B2      EXTRA POSITION 1
- =K+KSE-B2-W1    1 m    PVC-OB 4x0,34mm2
- =K+KSE-B3      LOW SPEED EXTRA POSITION 1 FROM ABOVE
- =K+KSE-B3-W1    1 m    PVC-OB 4x0,34mm2
- =K+KSE-B4      LOW SPEED EXTRA POSITION 2 FROM BELOW
- =K+KSE-B4-W1    5 m    PVC-OB 4x0,34mm2
- =K+KSE-B5      EXTRA POSITION 2
- =K+KSE-B5-W1    5 m    PVC-OB 4x0,34mm2
- =K+KSE-B6      LOW SPEED EXTRA POSITION 2 FROM ABOVE
- =K+KSE-B6-W1    5 m    PVC-OB 4x0,34mm2
  
- =K+KSE-U1      CONNECTION UNIT ADDITIONAL POSITION



Customer  
**Qimarox B.V.**  
 Harderwijk  
 The Netherlands

Type  
 Prorunner mk10

Customer attribute

Ordernumber  
**QS16xxxx**

Serial number  
 mk10 16xxxxx

Description  
 Layout Column Standard, 2 additional positions

Date	2-6-2015	= K
Ed.	DSP	+ KSE
		Page <b>15.1</b>

Sales example

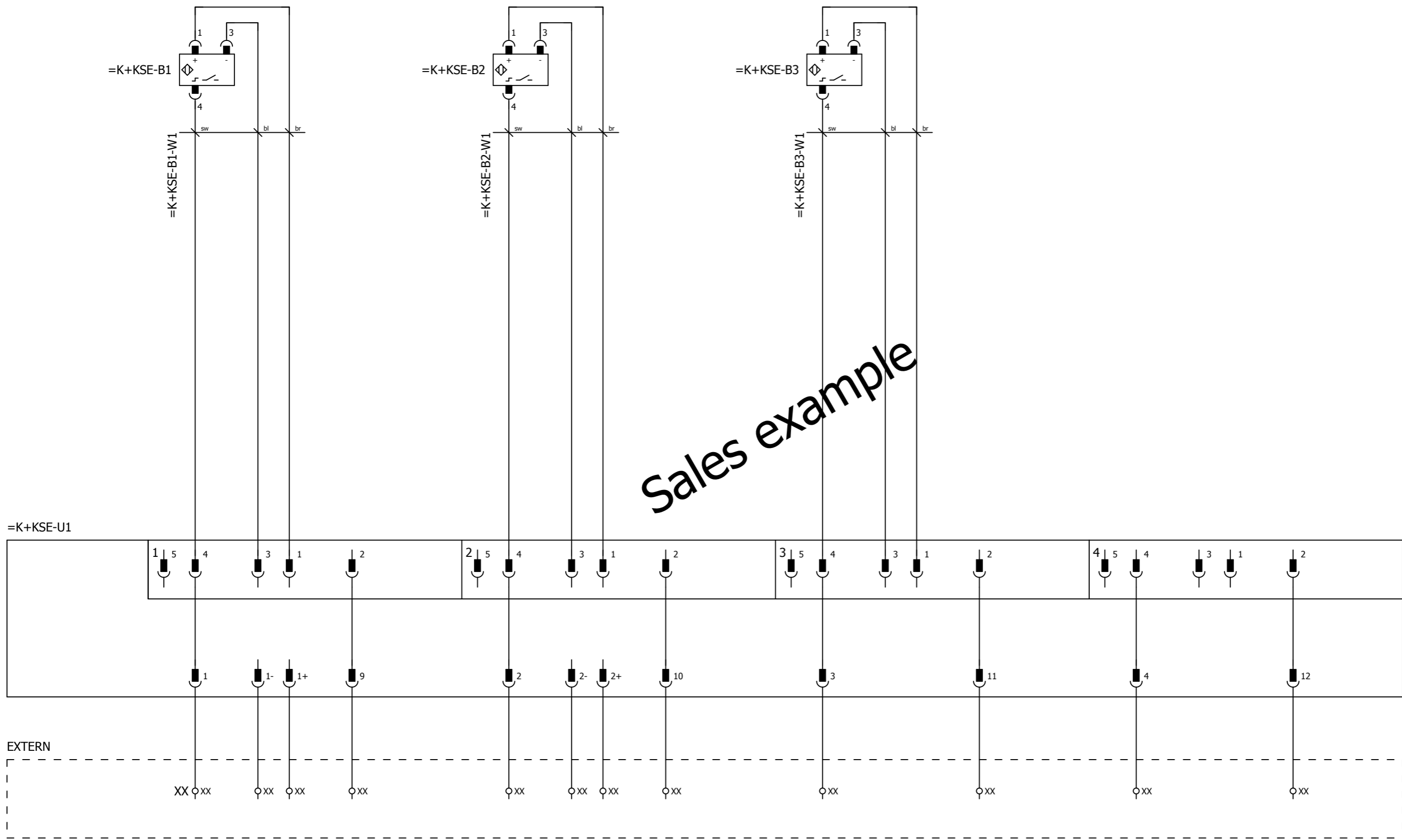

CONNECTION UNIT ADDITIONAL POSITION      LOW SPEED EXTRA POSITION 1 FROM BELOW      SPARE      EXTRA POSITION 1      SPARE      LOW SPEED EXTRA POSITION 1 FROM ABOVE      SPARE      SPARE

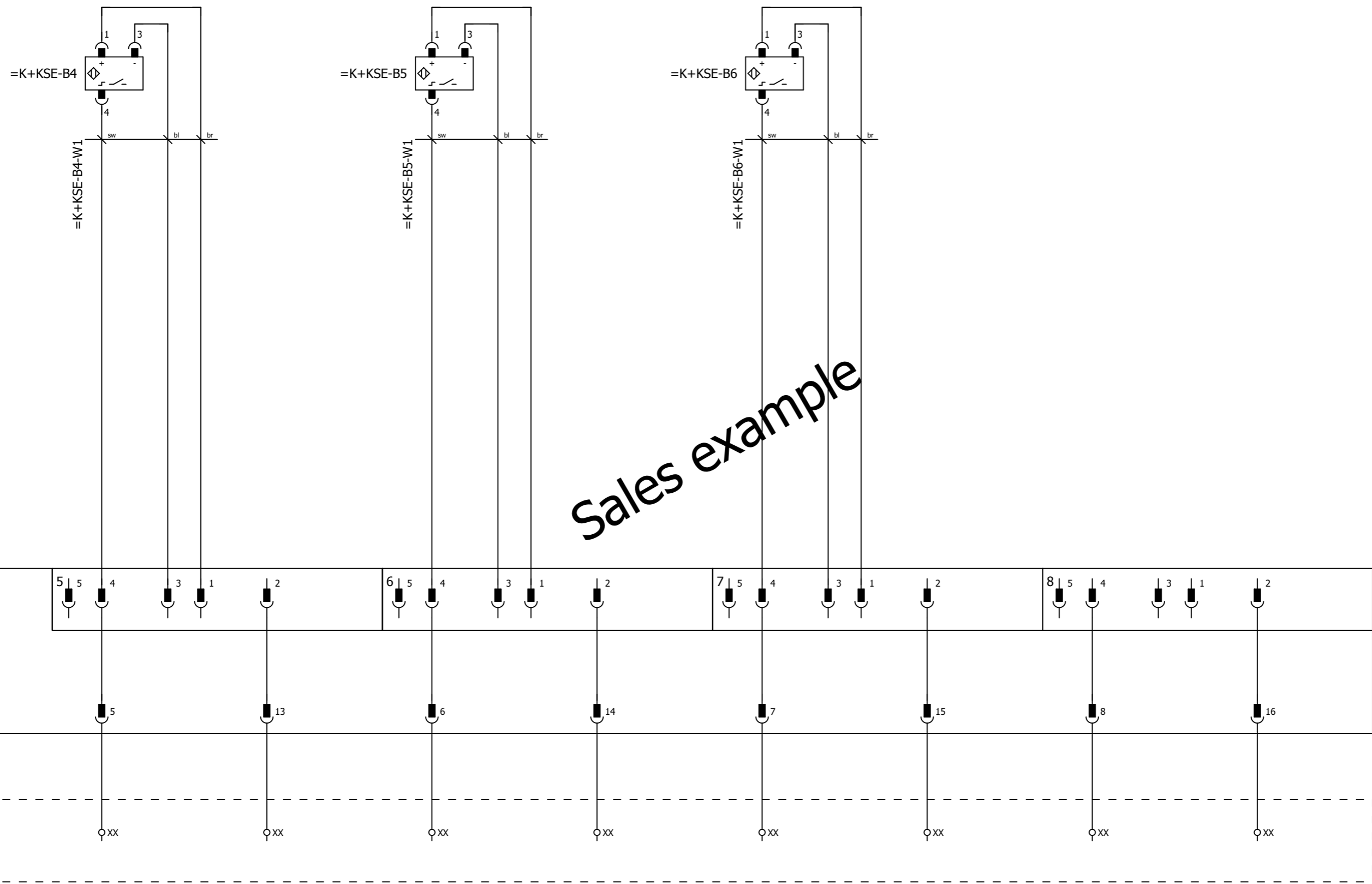

Sales example

CONNECTION UNIT ADDITIONAL POSITION      LOW SPEED EXTRA POSITION 2 FROM BELOW      SPARE      EXTRA POSITION 2      SPARE      LOW SPEED EXTRA POSITION 2 FROM ABOVE      SPARE      SPARE      SPARE

# Parts list

Position	Quantity	Article number	Discription
-B1	1	1000932	Inductive proximity sensor
-B1-W1	1	1001601	Prefab cable, PVC, 1 meter, connector M12 male 90°+ M12 female 90°, 4-pole
-B2	1	1000932	Inductive proximity sensor
-B2-W1	1	1001601	Prefab cable, PVC, 1 meter, connector M12 male 90°+ M12 female 90°, 4-pole
-B3	1	1000932	Inductive proximity sensor
-B3-W1	1	1001601	Prefab cable, PVC, 1 meter, connector M12 male 90°+ M12 female 90°, 4-pole
-B4	1	1000932	Inductive proximity sensor
-B4-W1	1	1001326	Prefab cable, PVC, 5 meter, connector M12 male 90°+ M12 female 90°, 4-pole
-B5	1	1000932	Inductive proximity sensor
-B5-W1	1	1001326	Prefab cable, PVC, 5 meter, connector M12 male 90°+ M12 female 90°, 4-pole
-B6	1	1000932	Inductive proximity sensor
-B6-W1	1	1001326	Prefab cable, PVC, 5 meter, connector M12 male 90°+ M12 female 90°, 4-pole
-U1	1	1003309	Connection unit, 8-fold, 5-pole, M12

Sales example



Nobelstraat 43  
3846 CE Harderwijk  
The Netherlands

Phone: +31 341 - 436700  
Fax: +31 341 - 436701  
www.qimarox.com  
info@qimarox.com

Mounting group:       =K       Column prorranner mk10

Mounting location:   +KE       Column encoder

Sales example



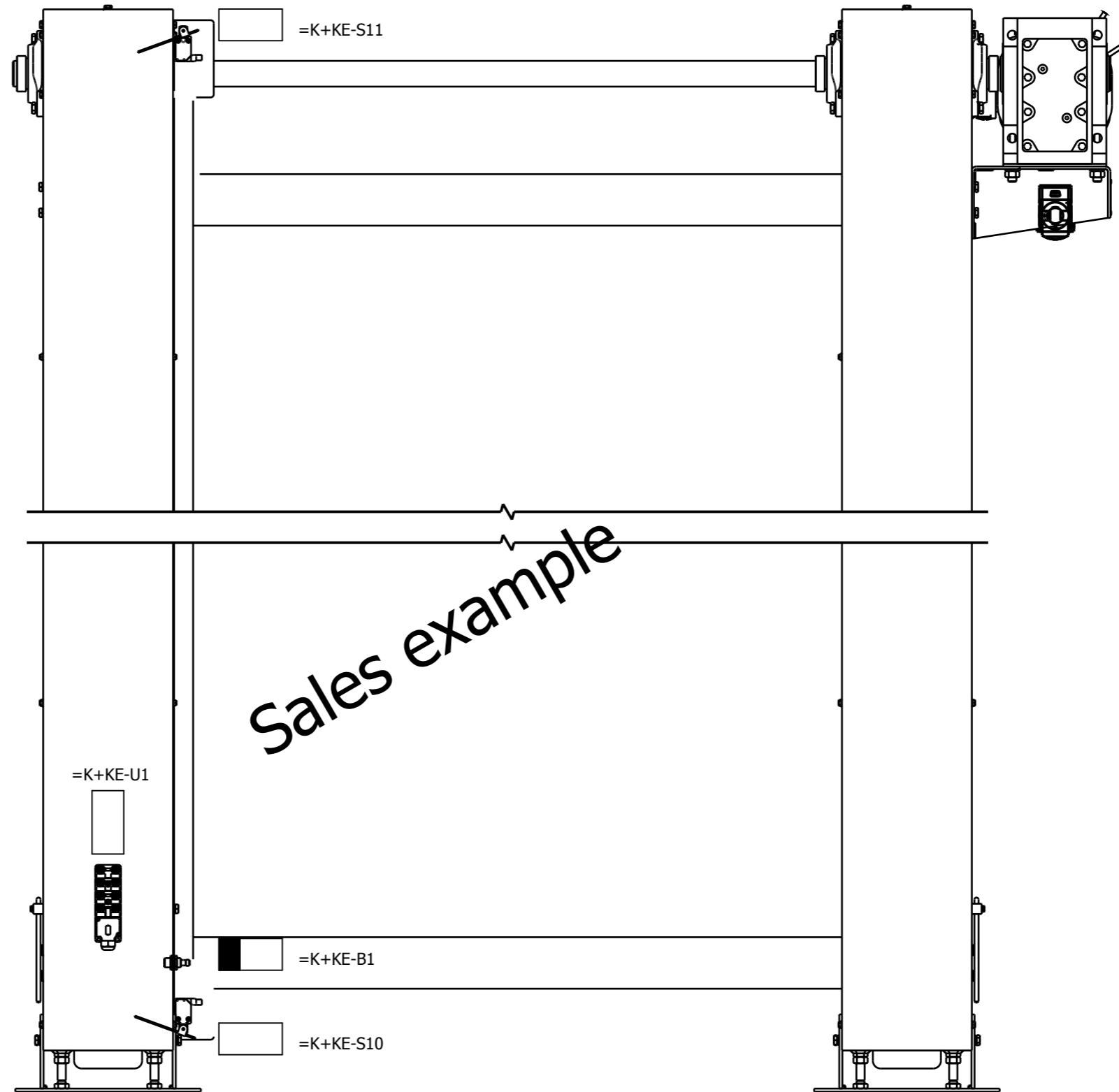

**LEGEND:**

- =K+KE-B1 HOME POSITION
- =K+KE-B1-W1 1 m PVC-OB 4x0,34mm<sup>2</sup>
- =K+KE-S10 END-SWITCH BELOW
- =K+KE-S10-W1 1 m PVC-OB 4x0,34mm<sup>2</sup>
- =K+KE-S11 END-SWITCH ABOVE
- =K+KE-S11-W1 5 m PVC-OB 4x0,34mm<sup>2</sup>
  
- =K+KE-U1 CONNECTION UNIT COLUMN PRORUNNER MK10

1

500

Sales example

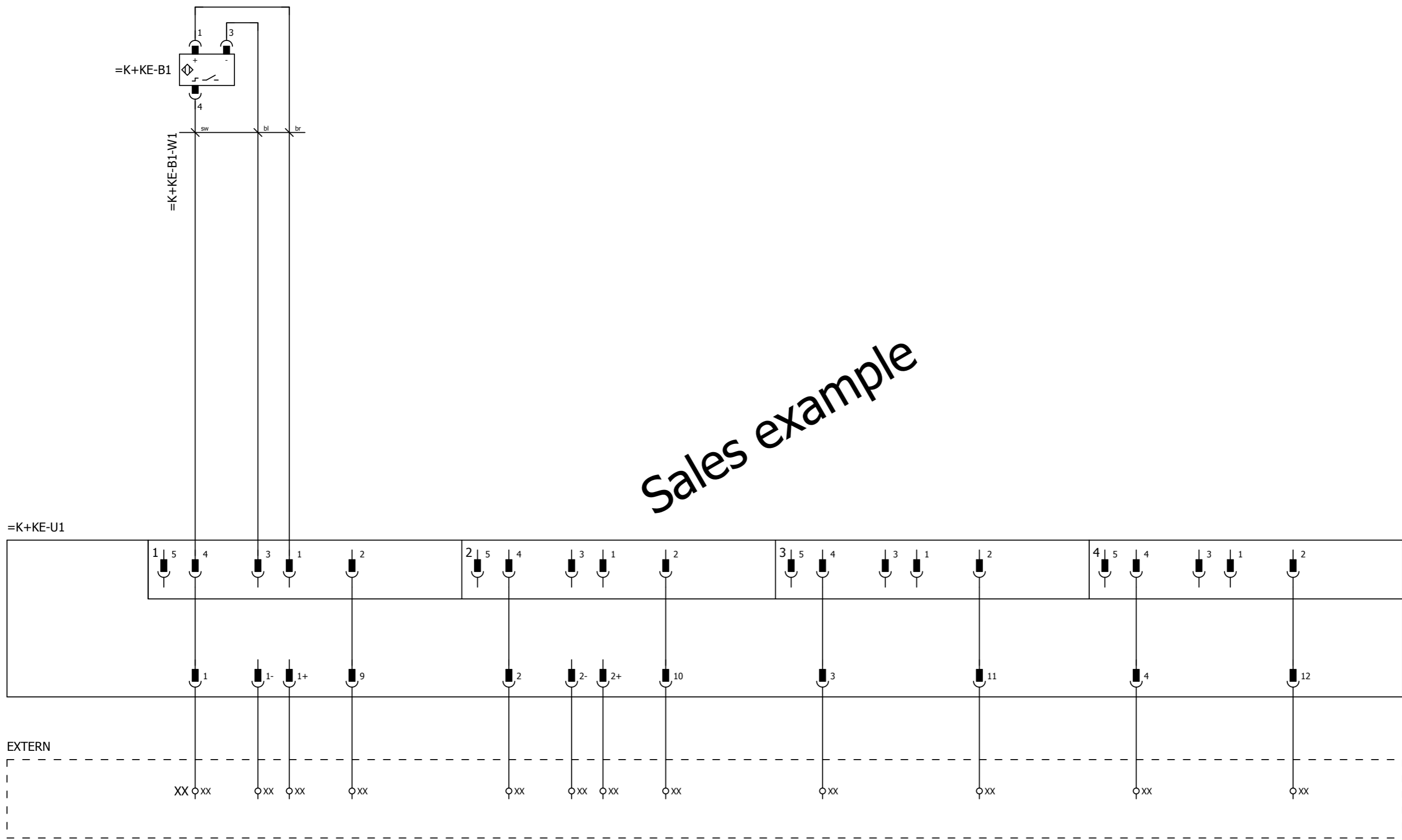

CONNECTION UNIT COLUMN PRORUNNER MK10      HOME POSITION      SPARE      SPARE      SPARE      SPARE      SPARE      SPARE      SPARE

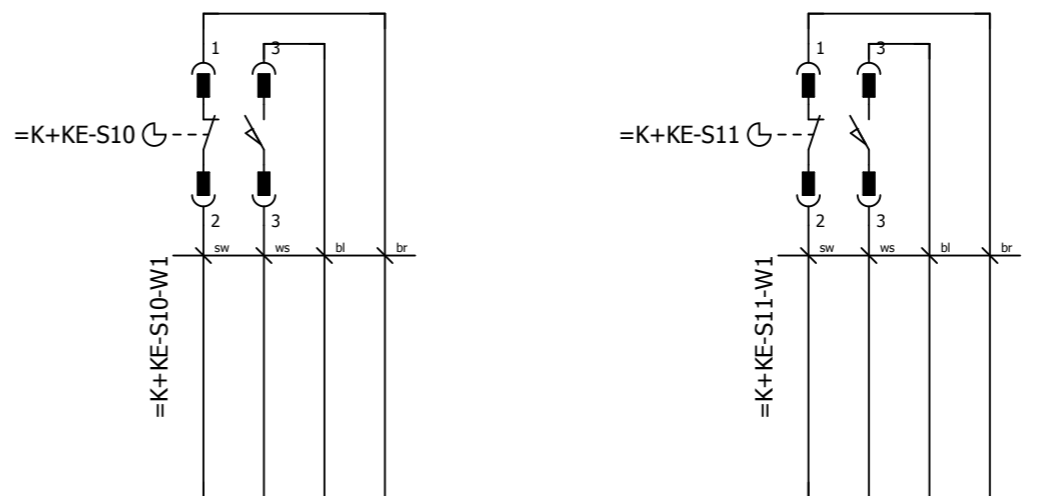

Sales example

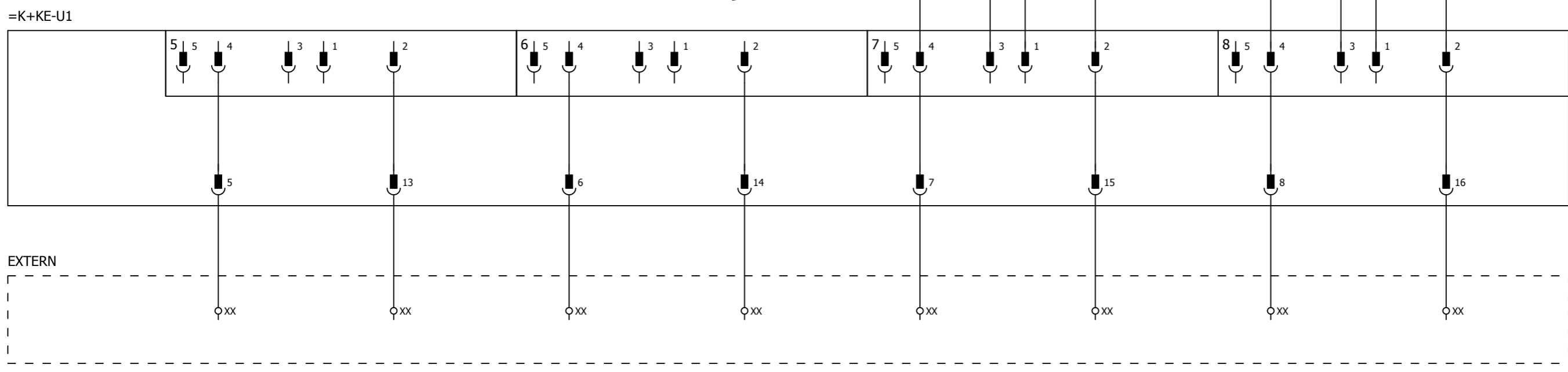

CONNECTION UNIT COLUMN PRORUNNER MK10      SPARE      SPARE      SPARE      SPARE      END-SWITCH BELOW      SPARE      END-SWITCH ABOVE      SPARE

# Parts list

Position	Quantity	Article number	Discription
-B1	1	1000932	Inductive proximity sensor
-B1-W1	1	1001601	Prefab cable, PVC, 1 meter, connector M12 male 90°+ M12 female 90°, 4-pole
-S10	1	AE0005524	Limit switch basic contact element, M12 connector
-S10	1	AE0005537	Limit switch lever
-S10	1	AE0005534	Limit switch control head
-S10-W1	1	1001601	Prefab cable, PVC, 1 meter, connector M12 male 90°+ M12 female 90°, 4-pole
-S11	1	AE0005524	Limit switch basic contact element, M12 connector
-S11	1	AE0005537	Limit switch lever
-S11	1	AE0005534	Limit switch control head
-S11-W1	1	1001326	Prefab cable, PVC, 5 meter, connector M12 male 90°+ M12 female 90°, 4-pole
-U1	1	1003309	Connection unit, 8-fold, 5-pole, M12

Sales example



Nobelstraat 43  
 3846 CE Harderwijk  
 The Netherlands

Phone: +31 341 - 436700  
 Fax: +31 341 - 436701  
 www.qimarox.com  
 info@qimarox.com

Mounting group: =D Carrier

Mounting location: +D Carrier

Sales example

Sales example

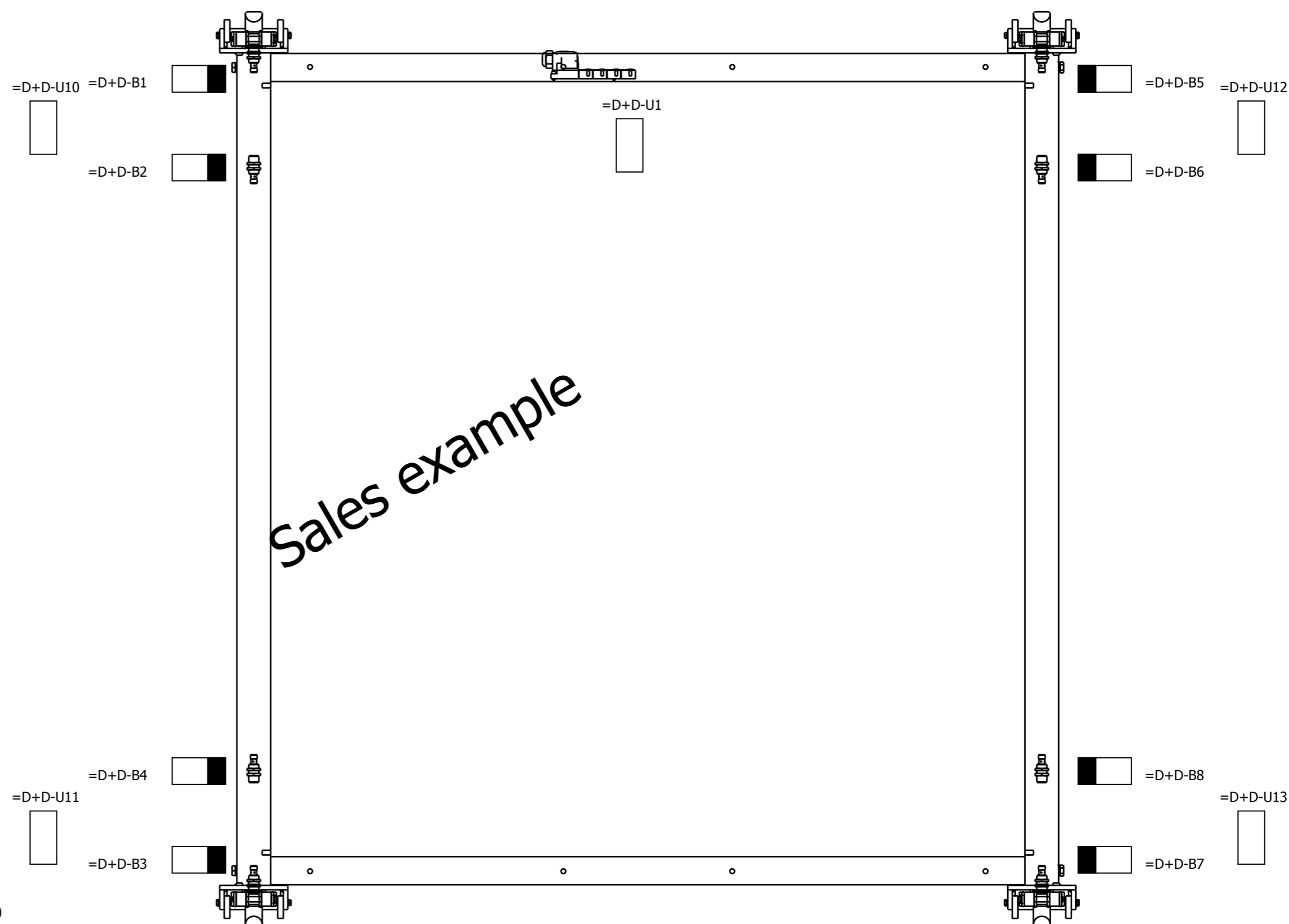

**LEGEND:**

- =D+D-B1 CARRIER CHAIN 1 OK
- =D+D-B1-W1 1 m PVC-OB 4x0,34mm2
- =D+D-B2 CARRIER DROP PROTECTION 1 OK
- =D+D-B2-W1 1 m PVC-OB 4x0,34mm2
- =D+D-B3 CARRIER CHAIN 2 OK
- =D+D-B3-W1 1 m PVC-OB 4x0,34mm2
- =D+D-B4 CARRIER DROP PROTECTION 2 OK
- =D+D-B4-W1 1 m PVC-OB 4x0,34mm2
- =D+D-B5 CARRIER CHAIN 3 OK
- =D+D-B5-W1 1 m PVC-OB 4x0,34mm2
- =D+D-B6 CARRIER DROP PROTECTION 3 OK
- =D+D-B6-W1 1 m PVC-OB 4x0,34mm2
- =D+D-B7 CARRIER CHAIN 4 OK
- =D+D-B7-W1 1 m PVC-OB 4x0,34mm2
- =D+D-B8 CARRIER DROP PROTECTION 4 OK
- =D+D-B8-W1 1 m PVC-OB 4x0,34mm2
  
- =D+D-U1 CONNECTION UNIT CARRIER PRORUNNER MK10
- =D+D-U10 T-COUPLER CARRIER CHAIN 1
- =D+D-U10-W1 2 m PVC-OB 4x0,34mm2
- =D+D-U11 T-COUPLER CARRIER CHAIN 2
- =D+D-U11-W1 2 m PVC-OB 4x0,34mm2
- =D+D-U12 T-COUPLER CARRIER CHAIN 3
- =D+D-U12-W1 2 m PVC-OB 4x0,34mm2
- =D+D-U13 T-COUPLER CARRIER CHAIN 4
- =D+D-U13-W1 2 m PVC-OB 4x0,34mm2

1

500



Customer  
**Qimarox B.V.**  
 Harderwijk  
 The Netherlands

Type  
 Prorunner mk10

Ordernumber  
**QS16xxxx**

Serial number  
 mk10 16xxxxx

Description  
 Layout Carrier

Date  
 3-6-2015

Ed.  
 DSP

= D  
 + D  
 Page **15**

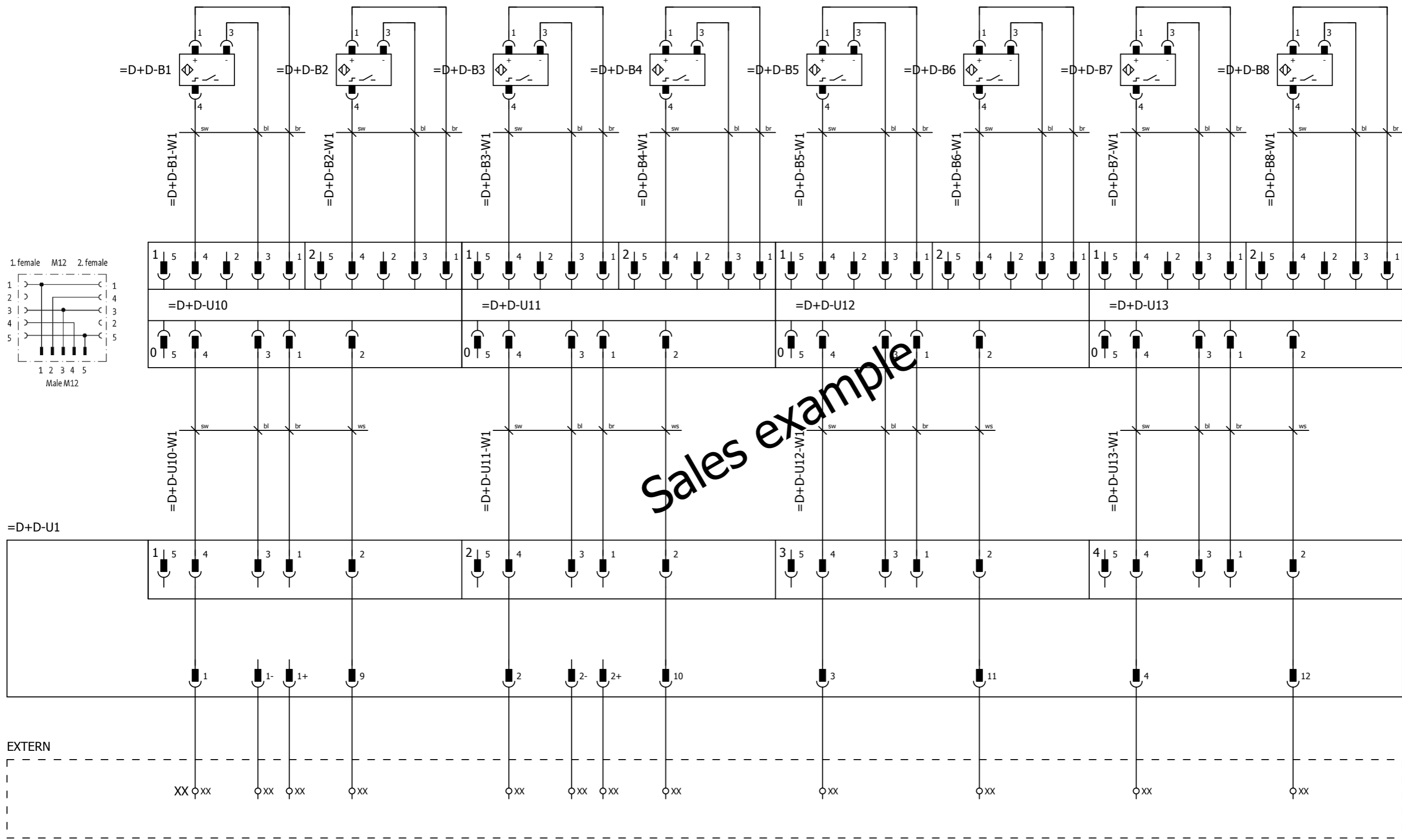

Sales example

CONNECTION UNIT CARRIER PRORUNNER MK10      CARRIER CHAIN 1 OK      CARRIER DROP PROTECTION 1 OK      CARRIER CHAIN 2 OK      CARRIER DROP PROTECTION 2 OK      CARRIER CHAIN 3 OK      CARRIER DROP PROTECTION 3 OK      CARRIER CHAIN 4 OK      CARRIER DROP PROTECTION 4 OK



Customer  
**Qimarox B.V.**  
 Harderwijk  
 The Netherlands

Type  
 Prorunner mk10

Ordernumber  
**QS16xxxx**

Serial number  
 mk10 16xxxxx

Description  
 Field components

Date	1-11-2016	= D
Ed.	DSP	+ D
		Page <b>500</b>

Sales example

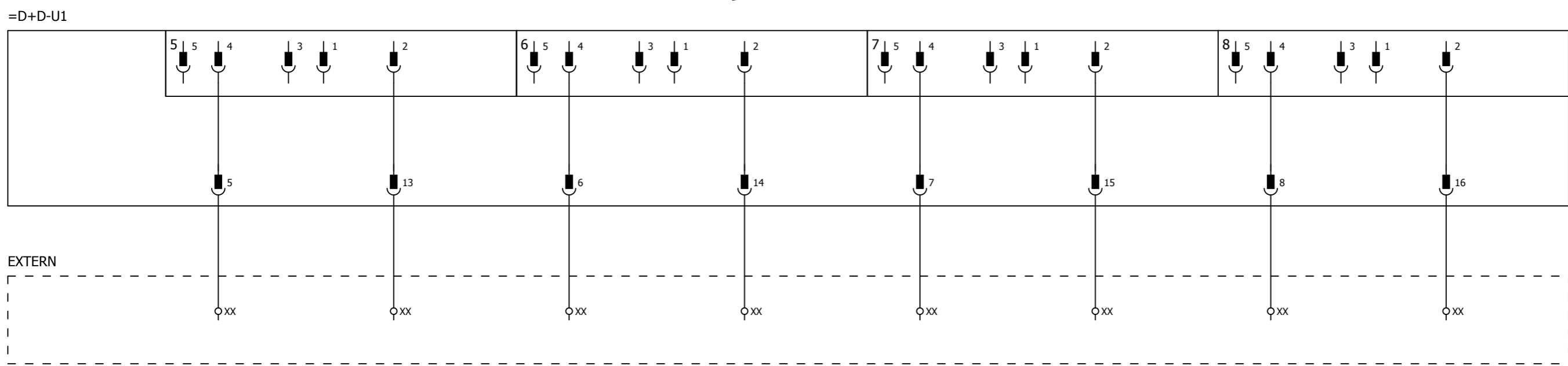

CONNECTION UNIT CARRIER PRORUNNER MK10

SPARE                      SPARE                      SPARE                      SPARE                      SPARE                      SPARE                      SPARE                      SPARE



Customer  
**Qimarox B.V.**  
 Harderwijk  
 The Netherlands

Type  
 Prorunner mk10

Customer attribute

Ordernumber  
**QS16xxxx**

Serial number  
 mk10 16xxxxx

Description  
 Field components

Date	1-11-2016	= D
Ed.	DSP	+ D
		Page <b>501</b>



# Parts list

Position	Quantity	Article number	Description
-B1	1	1000932	Inductive proximity sensor
-B1-W1	1	1001601	Prefab cable, PVC, 1 meter, connector M12 male 90°+ M12 female 90°, 4-pole
-B2	1	1000932	Inductive proximity sensor
-B2-W1	1	1001601	Prefab cable, PVC, 1 meter, connector M12 male 90°+ M12 female 90°, 4-pole
-B3	1	1000932	Inductive proximity sensor
-B3-W1	1	1001601	Prefab cable, PVC, 1 meter, connector M12 male 90°+ M12 female 90°, 4-pole
-B4	1	1000932	Inductive proximity sensor
-B4-W1	1	1001601	Prefab cable, PVC, 1 meter, connector M12 male 90°+ M12 female 90°, 4-pole
-B5	1	1000932	Inductive proximity sensor
-B5-W1	1	1001601	Prefab cable, PVC, 1 meter, connector M12 male 90°+ M12 female 90°, 4-pole
-B6	1	1000932	Inductive proximity sensor
-B6-W1	1	1001601	Prefab cable, PVC, 1 meter, connector M12 male 90°+ M12 female 90°, 4-pole
-B7	1	1000932	Inductive proximity sensor
-B7-W1	1	1001601	Prefab cable, PVC, 1 meter, connector M12 male 90°+ M12 female 90°, 4-pole
-B8	1	1000932	Inductive proximity sensor
-B8-W1	1	1001601	Prefab cable, PVC, 1 meter, connector M12 male 90°+ M12 female 90°, 4-pole
-U1	1	1003309	Connection unit, 8-fold, 5-pole, M12
-U10	1	1003313	T-Coupler 5p Male M12 / 2x 4p Female M12
-U10-W1	1	1001528	Prefab cable, PVC, 2 meter, connector M12 male 90°+ M12 female 90°, 4-pole
-U11	1	1003313	T-Coupler 5p Male M12 / 2x 4p Female M12
-U11-W1	1	1001528	Prefab cable, PVC, 2 meter, connector M12 male 90°+ M12 female 90°, 4-pole
-U12	1	1003313	T-Coupler 5p Male M12 / 2x 4p Female M12
-U12-W1	1	1001528	Prefab cable, PVC, 2 meter, connector M12 male 90°+ M12 female 90°, 4-pole
-U13	1	1003313	T-Coupler 5p Male M12 / 2x 4p Female M12
-U13-W1	1	1001528	Prefab cable, PVC, 2 meter, connector M12 male 90°+ M12 female 90°, 4-pole

Sales example



Customer  
**Qimarox B.V.**  
 Harderwijk  
 The Netherlands

Type  
 Prorunner mk10

Ordernumber  
 QS16xxxx

Serial number  
 mk10 16xxxxx

Description  
 Parts list

Date  
 1-11-2016

Ed.  
 DSP

= D

+ D

Page

2000



Nobelstraat 43  
3846 CE Harderwijk  
The Netherlands

Phone: +31 341 - 436700  
Fax: +31 341 - 436701  
www.qimarox.com  
info@qimarox.com

Mounting group: =T Conveyor on carrier

Mounting location: +T Conveyor

Sales example



**LEGEND:**

- =T+T-B1 PROTECTION CARRIER NOT FREE 1
- =T+T-B1-W1 1 m PVC-OB 4x0,25mm2
- =T+T-B2 PROTECTION CARRIER NOT FREE 2
- =T+T-B2-W1 1 m PVC-OB 4x0,25mm2
  
- =D+D-U1 CONNECTION UNIT CARRIER PRORUNNER MK10

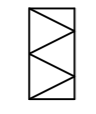

=T+T-B1

=D+D-U1

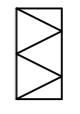

=T+T-B2

Sales example

=D+D-U1

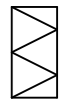

=T+T-B1

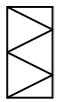

=T+T-B2

**LEGEND:**

- =T+T-B1      PROTECTION CARRIER NOT FREE 1
- =T+T-B1-W1    1 m    PVC-OB 4x0,25mm2
- =T+T-B2      PROTECTION CARRIER NOT FREE 2
- =T+T-B2-W1    1 m    PVC-OB 4x0,25mm2
  
- =D+D-U1      CONNECTION UNIT CARRIER PRORUNNER MK10



Customer  
**Qimarox B.V.**  
 Harderwijk  
 The Netherlands

Type  
 Prorunner mk10

Customer attribute

Ordernumber  
**QS16xxxx**

Serial number  
 mk10 16xxxxx

Description  
 Layout Transporter chain conveyor

Date	3-6-2015	= T
Ed.	DSP	+ T
		Page <b>15.1</b>

Sales example

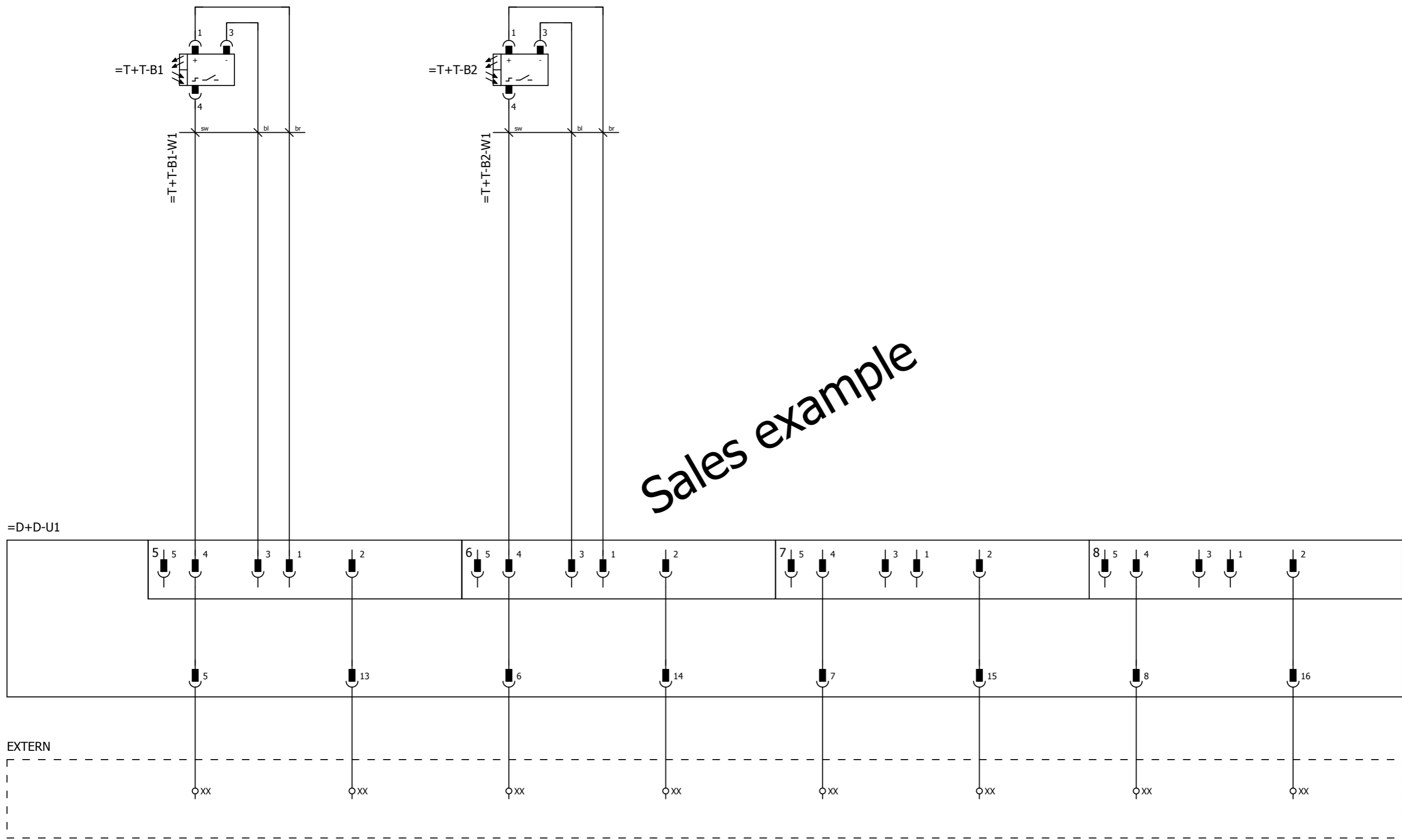

CONNECTION UNIT CARRIER PRORUNNER MK10      PROTECTION CARRIER NOT FREE 1      SPARE      PROTECTION CARRIER NOT FREE 2      SPARE      SPARE      SPARE      SPARE      SPARE

# Parts list

Position	Quantity	Article number	Discription
-B1	1	1005663	Reflex sensor
-B1	1	1003575	Reflector
-B1-W1	1	1003307	Prefab cable, PVC, 1 meter, connector M12 male + female M8, 4-pole
-B2	1	1005663	Reflex sensor
-B2	1	1003575	Reflector
-B2-W1	1	1003307	Prefab cable, PVC, 1 meter, connector M12 male + female M8, 4-pole

Sales example





Nobelstraat 43  
3846 CE Harderwijk  
The Netherlands

Phone: +31 341 - 436700  
Fax: +31 341 - 436701  
www.qimarox.com  
info@qimarox.com

Mounting group:        =T            Conveyor on carrier  
Mounting location:    +TS          Transporteur + stopklep

Sales example

Sales example

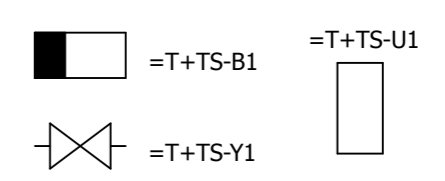
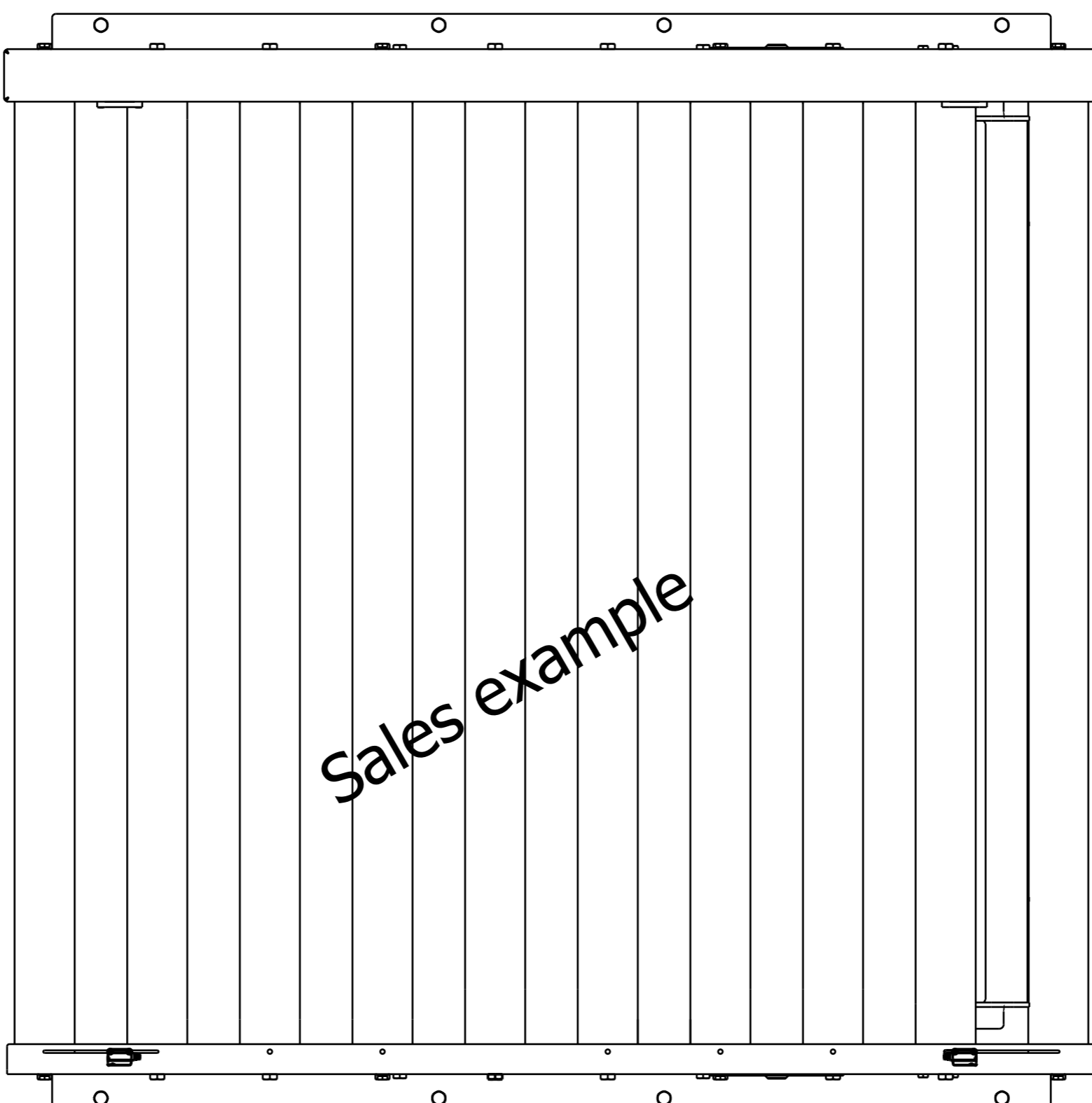

**LEGEND:**

- =T+T-B1 PROTECTION CARRIER NOT FREE 1
- =T+T-B1-W1 1 m PVC-OB 4x0,25mm2
- =T+T-B2 PROTECTION CARRIER NOT FREE 2
- =T+T-B2-W1 1 m PVC-OB 4x0,25mm2
- =T+TS-B1 TRANSPORTEUR STOPKLEP NEER
- =T+TS-B1-W1 1 m PVC-OB 4x0,34mm2
- =T+TS-Y1 AANSTURING TRANSPORTEUR STOPKLEP NEER
- =T+TS-Y1-W1 0,3 m PVC-OB 3x0,25mm2
- =T+TS-Y1-W2 1 m PVC-OB 4x0,34mm2
  
- =D+D-U1 CONNECTION UNIT CARRIER PRORUNNER MK10
- =T+TS-U1 AANSLUIT UNIT TRANSPORTEUR + STOPKLEP

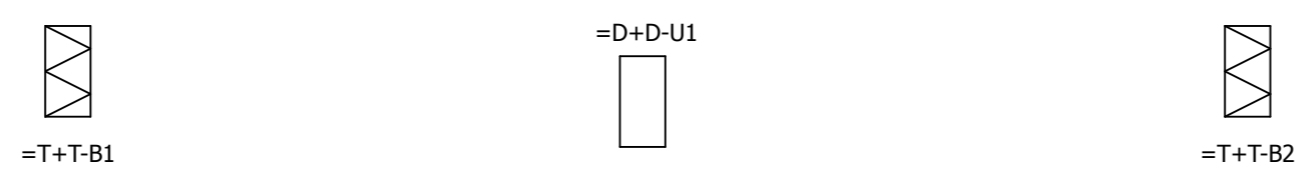



Sales example

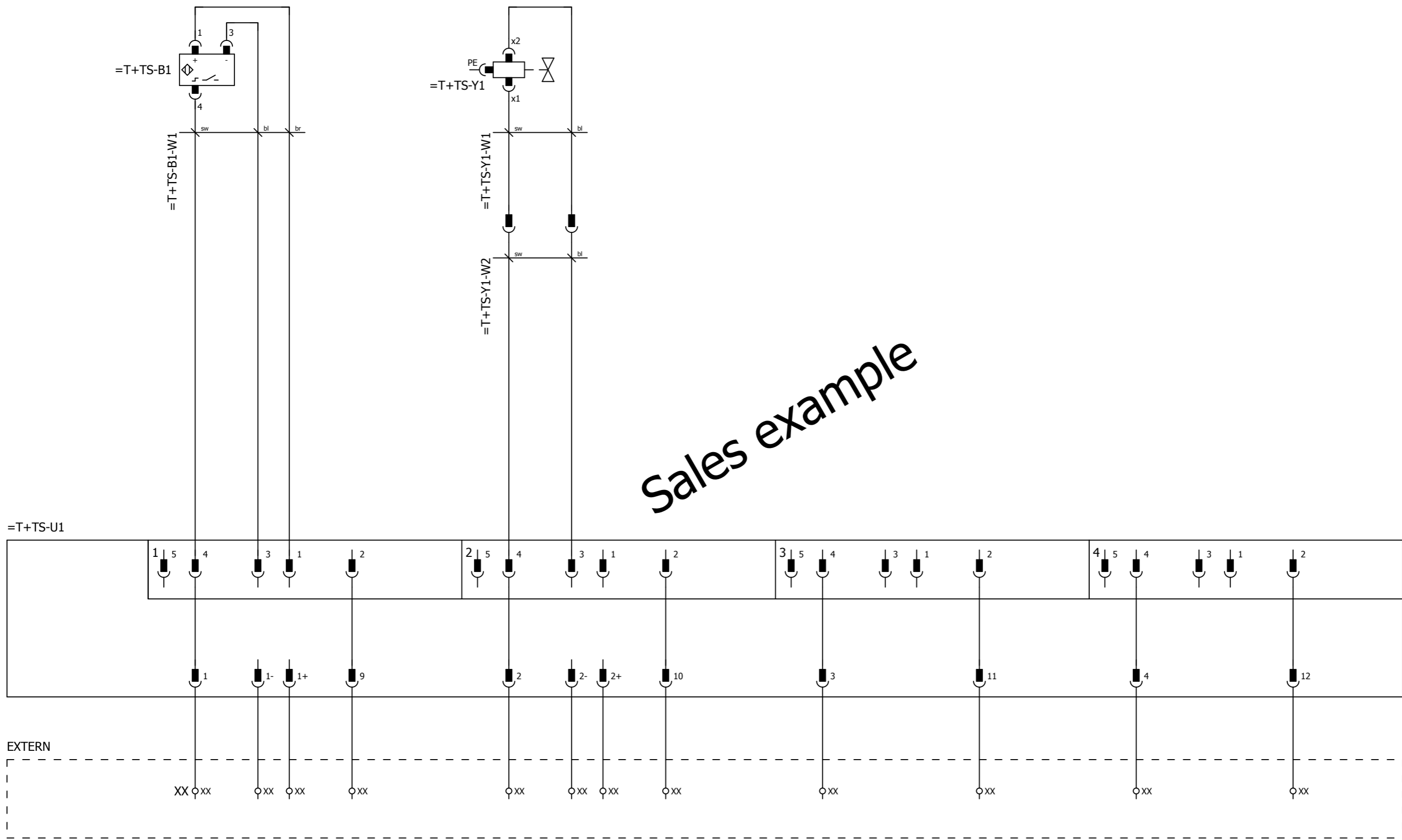

- AANSLUIT UNIT TRANSPORTEUR + STOPKLEP
- TRANSPORTEUR STOPKLEP NEER
- SPARE
- AANSTURING TRANSPORTEUR STOPKLEP NEER
- SPARE
- SPARE
- SPARE
- SPARE
- SPARE

Sales example

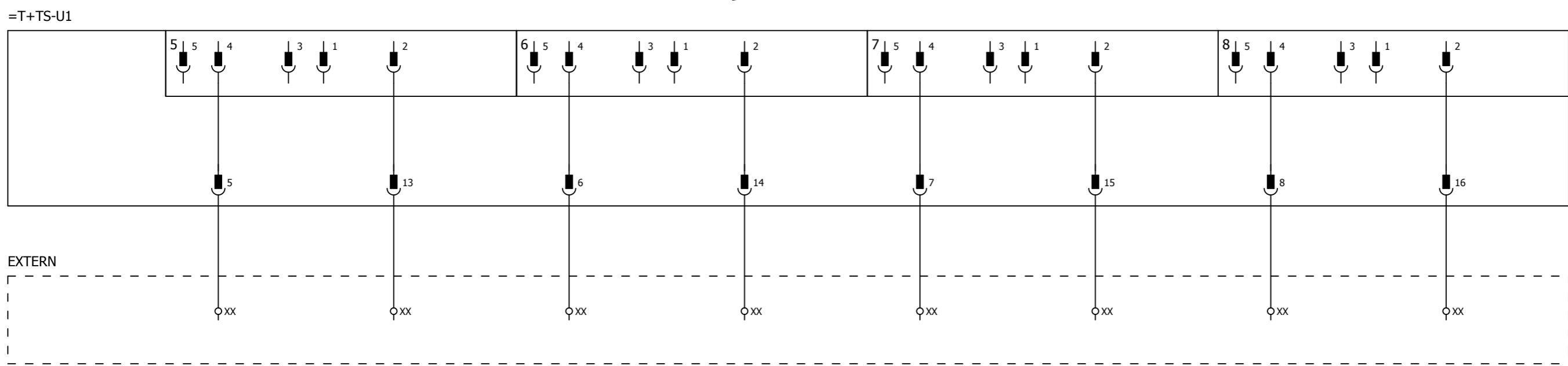

AANSLUIT UNIT TRANSPORTEUR + STOPKLEP

SPARE                      SPARE                      SPARE                      SPARE                      SPARE                      SPARE                      SPARE                      SPARE



Customer  
**Qimarox B.V.**  
 Harderwijk  
 The Netherlands

Type  
 Prorunner mk10

Customer attribute

Ordernumber  
**QS16xxxx**

Serial number  
 mk10 16xxxxx

Description  
 Field components

Date	3-6-2015	= T
Ed.	DSP	+ TS
		Page <b>501</b>

# Parts list

Position	Quantity	Article number	Discription
-B1	1	1005354	Reed contact, connector M12
-B1-W1	1	1001601	Prefab cable, PVC, 1 meter, connector M12 male 90°+ M12 female 90°, 4-pole
-U1	1	1003309	Connection unit, 8-fold, 5-pole, M12
-Y1	1		Coil see mechanical part list
-Y1-W1	1	1005959	Prefab cable, PVC, 0,3 meter, connector M12 male + female M8 straight 90°, 3-pole
-Y1-W2	1	1001601	Prefab cable, PVC, 1 meter, connector M12 male 90°+ M12 female 90°, 4-pole

Sales example



Customer  
**Qimarox B.V.**  
 Harderwijk  
 The Netherlands

Type  
 Prorunner mk10

Customer attribute

Ordernumber  
**QS16xxxx**

Serial number  
 mk10 16xxxxx

Description  
 Parts list

Date	1-11-2016	= T
Ed.	DSP	+ TS
		Page <b>2000</b>



Nobelstraat 43  
3846 CE Harderwijk  
The Netherlands

Phone: +31 341 - 436700  
Fax: +31 341 - 436701  
www.qimarox.com  
info@qimarox.com

Mounting group:        =T            Conveyor on carrier  
Mounting location:    +TC          Transporteur + centrering

Sales example

Sales example

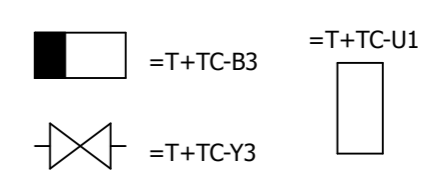
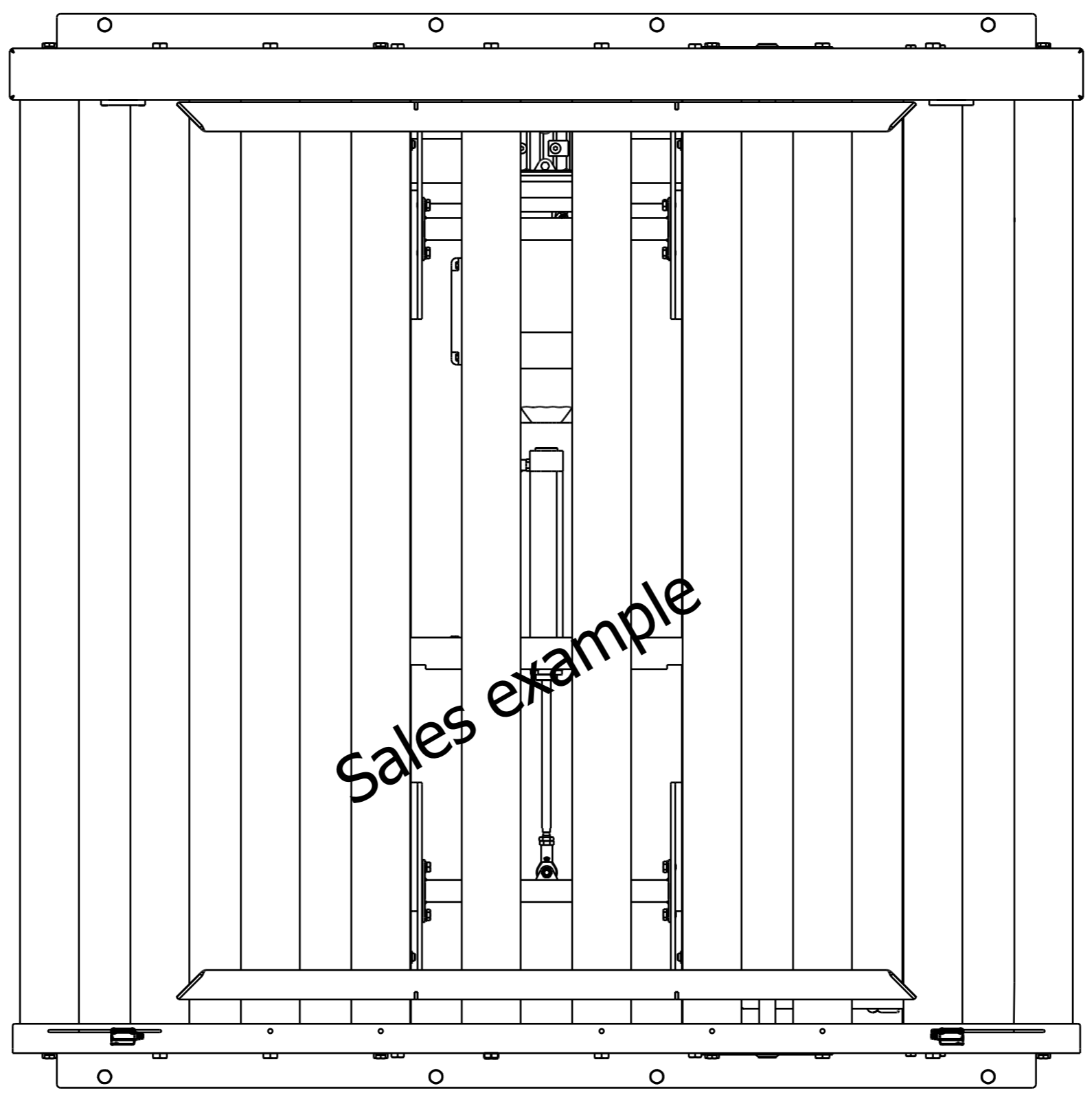

**LEGEND:**

- =T+T-B1 PROTECTION CARRIER NOT FREE 1
- =T+T-B1-W1 1 m PVC-OB 4x0,25mm2
- =T+T-B2 PROTECTION CARRIER NOT FREE 2
- =T+T-B2-W1 1 m PVC-OB 4x0,25mm2
- =T+TC-B3 TRANSPORTEUR CENTRERING GEOPEND
- =T+TC-B3-W1 1 m PVC-OB 4x0,34mm2
- =T+TC-Y3 AANSTURING TRANSPORTEUR CENTRERING SLUITEN
- =T+TC-Y3-W1 0,3 m PVC-OB 3x0,25mm2
- =T+TC-Y3-W2 1 m PVC-OB 4x0,34mm2
  
- =D+D-U1 CONNECTION UNIT CARRIER PRORUNNER MK10
- =T+TC-U1 AANSLUIT UNIT TRANSPORTEUR + CENTRERING

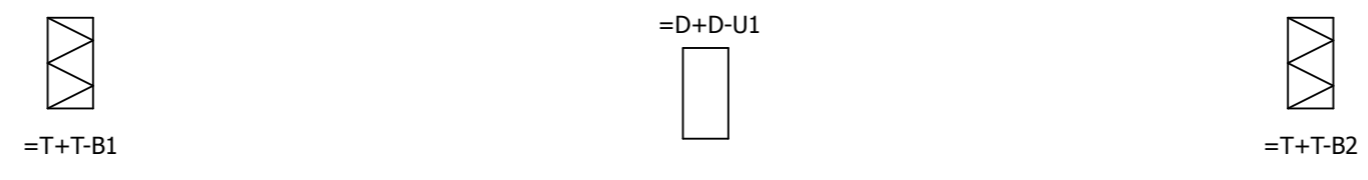

Sales example

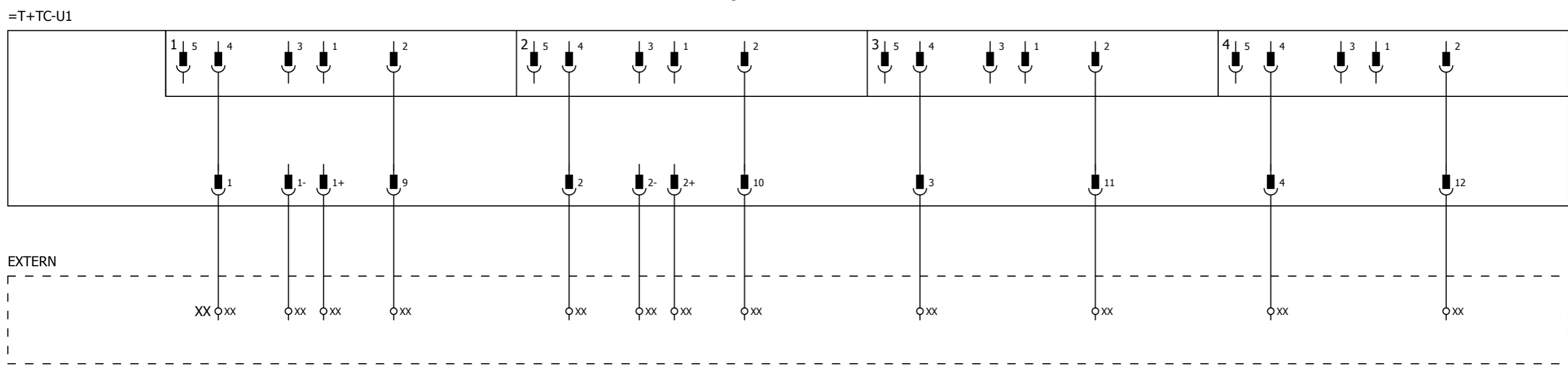

AANSLUIT UNIT  
TRANSPORTEUR  
+ CENTRERING

SPARE                      SPARE                      SPARE                      SPARE                      SPARE                      SPARE                      SPARE                      SPARE



Customer  
**Qimarox B.V.**  
Harderwijk  
The Netherlands

Type  
Prorunner mk10

Customer attribute

Ordernumber  
**QS16xxxx**

Serial number  
mk10 16xxxxx

Description  
Field components

Date	1-11-2016	= T
Ed.	DSP	+ TC
		Page <b>500</b>

Sales example

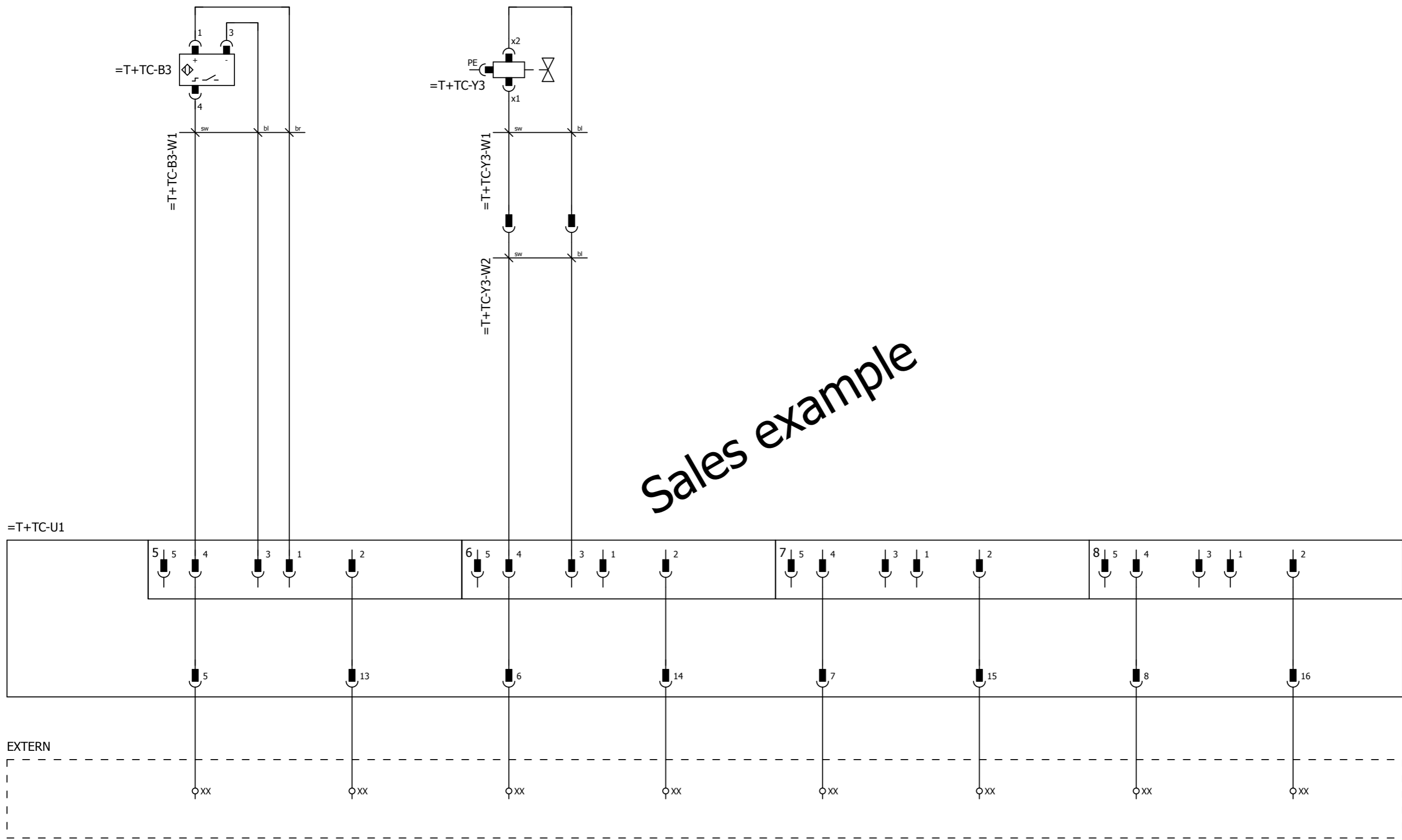

- AANSLUIT UNIT TRANSPORTEUR + CENTRERING
- TRANSPORTEUR CENTRERING GEOPEND
- SPARE
- AANSTURING TRANSPORTEUR CENTRERING SLUITEN
- SPARE
- SPARE
- SPARE
- SPARE
- SPARE

# Parts list

Position	Quantity	Article number	Discription
-B3	1	1005354	Reed contact, connector M12
-B3-W1	1	1001601	Prefab cable, PVC, 1 meter, connector M12 male 90°+ M12 female 90°, 4-pole
-U1	1	1003309	Connection unit, 8-fold, 5-pole, M12
-Y3	1		Coil see mechanical part list
-Y3-W1	1	1005959	Prefab cable, PVC, 0,3 meter, connector M12 male + female M8 straight 90°, 3-pole
-Y3-W2	1	1001601	Prefab cable, PVC, 1 meter, connector M12 male 90°+ M12 female 90°, 4-pole

Sales example



Customer  
**Qimarox B.V.**  
 Harderwijk  
 The Netherlands

Type  
 Prorunner mk10

Ordernumber  
**QS16xxxx**

Customer attribute  
 Serial number  
 mk10 16xxxxx

Description  
 Parts list

Date	1-11-2016	= T
Ed.	DSP	+ TC
		Page <b>2000</b>





Nobelstraat 43  
3846 CE Harderwijk  
The Netherlands

Phone: +31 341 - 436700  
Fax: +31 341 - 436701  
www.qimarox.com  
info@qimarox.com

Mounting group:        =T            Conveyor on carrier  
Mounting location:    +TSC        Transporteur + stopklep + centrering

Sales example

Sales example

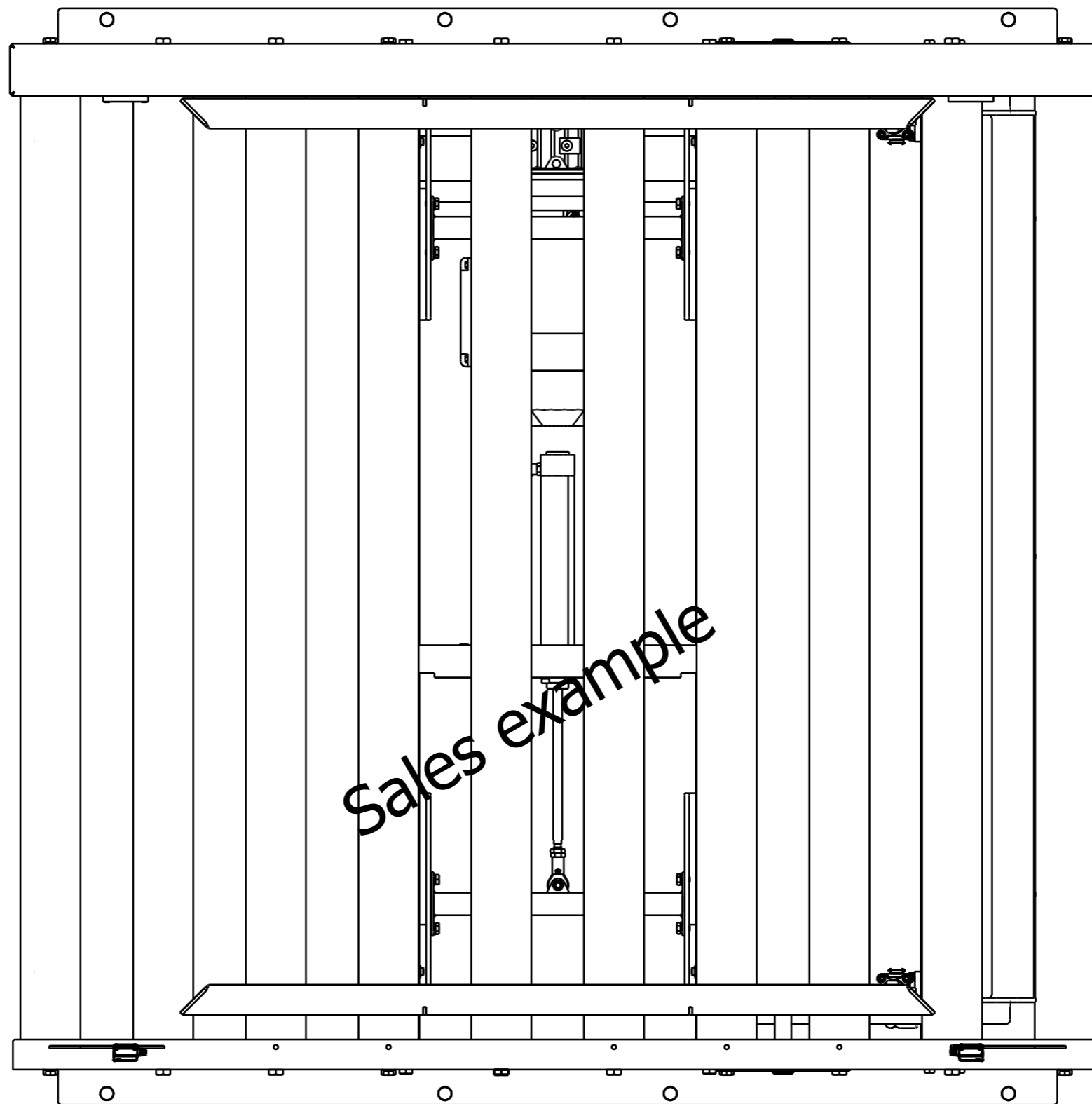

**LEGEND:**

- =T+T-B1 PROTECTION CARRIER NOT FREE 1
- =T+T-B1-W1 1 m PVC-OB 4x0,25mm2
- =T+T-B2 PROTECTION CARRIER NOT FREE 2
- =T+T-B2-W1 1 m PVC-OB 4x0,25mm2
- =T+TSC-B1 TRANSPORTEUR STOPKLEP NEER
- =T+TSC-B1-W1 1 m PVC-OB 4x0,34mm2
- =T+TSC-Y1 AANSTURING TRANSPORTEUR STOPKLEP NEER
- =T+TSC-Y1-W1 0,3 m PVC-OB 3x0,25mm2
- =T+TSC-Y1-W2 1 m PVC-OB 4x0,34mm2
- =T+TSC-B3 TRANSPORTEUR CENTRERING GEOPEND
- =T+TSC-B3-W1 1 m PVC-OB 4x0,34mm2
- =T+TSC-Y3 AANSTURING TRANSPORTEUR CENTRERING SLUITEN
- =T+TSC-Y3-W1 0,3 m PVC-OB 3x0,25mm2
- =T+TSC-Y3-W2 1 m PVC-OB 4x0,34mm2
  
- =D+D-U1 CONNECTION UNIT CARRIER PRORUNNER MK10
- =T+TSC-U1 AANSLUIT UNIT TRANSPORTEUR STOPKLEP + CENTRERING

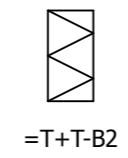
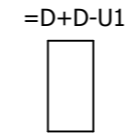
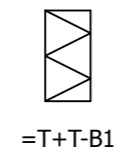
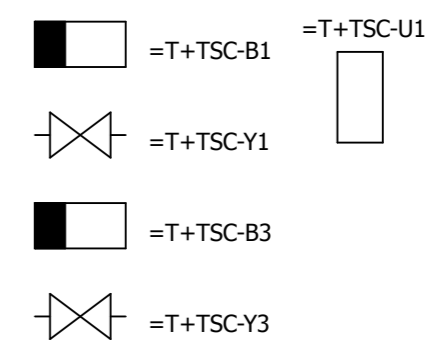

Sales example

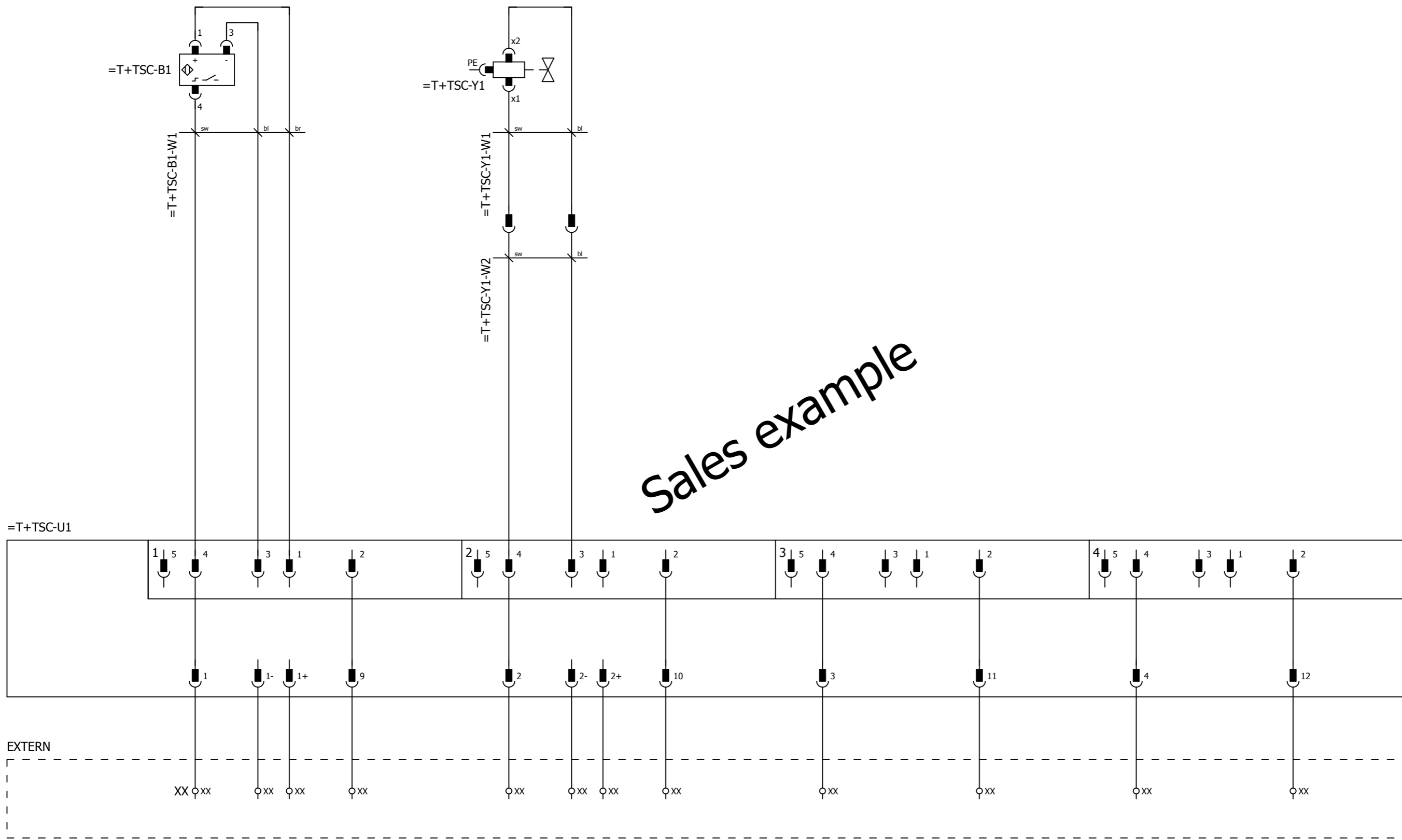

AANSLUIT UNIT  
TRANSPORTEUR  
STOPKLEP + CENTRERING

TRANSPORTEUR  
STOPKLEP  
NEER

SPARE

AANSTURING  
TRANSPORTEUR  
STOPKLEP  
NEER

SPARE

SPARE

SPARE

SPARE

SPARE

Sales example

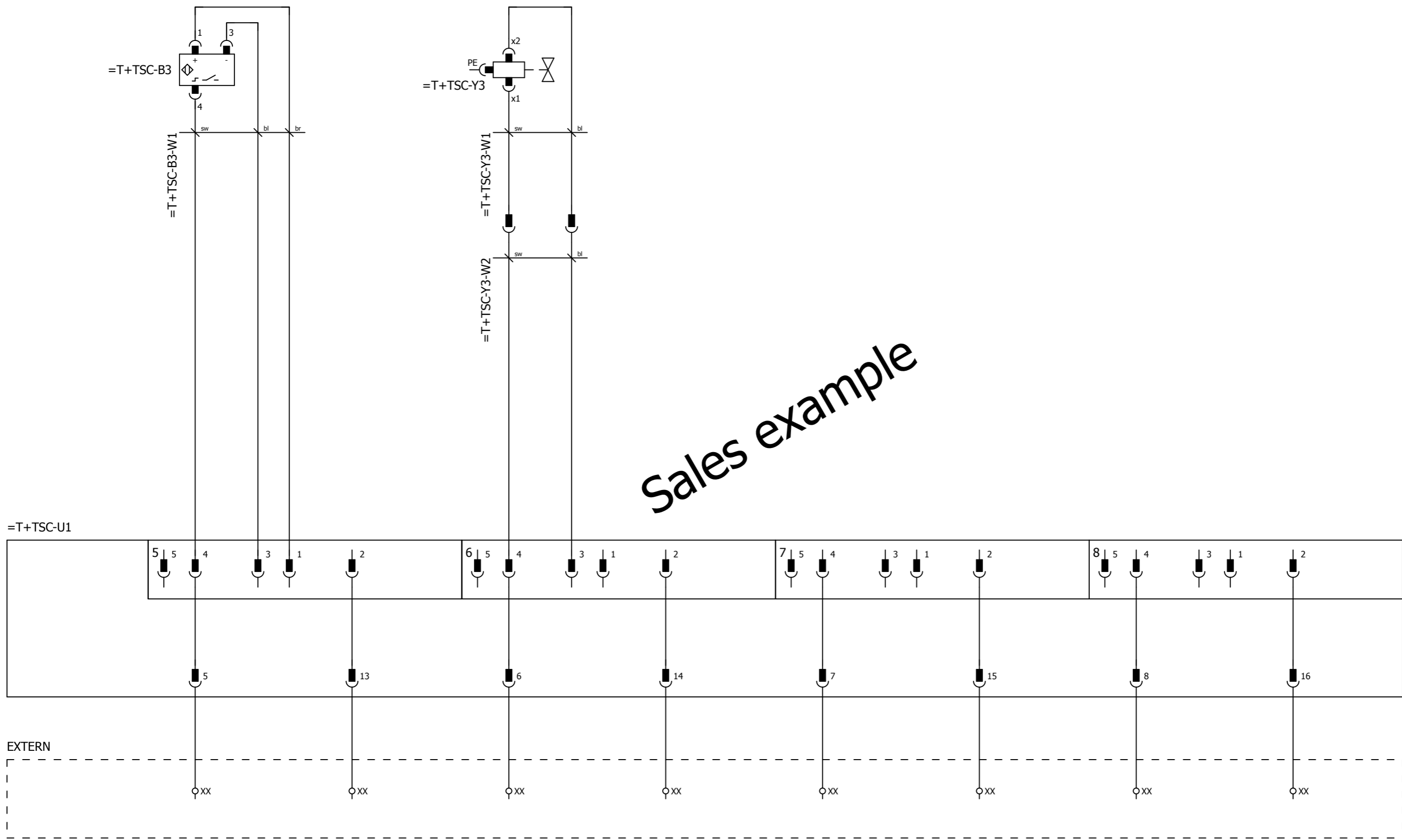

- AANSLUIT UNIT
- TRANSPORTEUR
- STOPKLEP + CENTRERING
- TRANSPORTEUR
- CENTRERING
- GEOPEND
- SPARE
- AANSTURING
- TRANSPORTEUR
- CENTRERING
- SLUITEN
- SPARE
- SPARE
- SPARE
- SPARE
- SPARE

# Parts list

Position	Quantity	Article number	Discription
-B1	1	1005354	Reed contact, connector M12
-B1-W1	1	1001601	Prefab cable, PVC, 1 meter, connector M12 male 90°+ M12 female 90°, 4-pole
-B3	1	1005354	Reed contact, connector M12
-B3-W1	1	1001601	Prefab cable, PVC, 1 meter, connector M12 male 90°+ M12 female 90°, 4-pole
-U1	1	1003309	Connection unit, 8-fold, 5-pole, M12
-Y1	1		Coil see mechanical part list
-Y1-W1	1	1005959	Prefab cable, PVC, 0,3 meter, connector M12 male + female M8 straight 90°, 3-pole
-Y1-W2	1	1001601	Prefab cable, PVC, 1 meter, connector M12 male 90°+ M12 female 90°, 4-pole
-Y3	1		Coil see mechanical part list
-Y3-W1	1	1005959	Prefab cable, PVC, 0,3 meter, connector M12 male + female M8 straight 90°, 3-pole
-Y3-W2	1	1001601	Prefab cable, PVC, 1 meter, connector M12 male 90°+ M12 female 90°, 4-pole

Sales example



Nobelstraat 43  
3846 CE Harderwijk  
The Netherlands

Phone: +31 341 - 436700  
Fax: +31 341 - 436701  
www.qimarox.com  
info@qimarox.com

Mounting group:        =T            Conveyor on carrier  
Mounting location:    +TS2        Transporteur + 2 stopkleppen

Sales example

Sales example

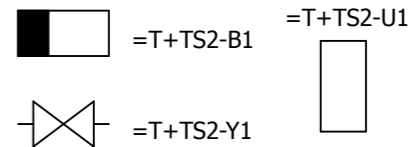
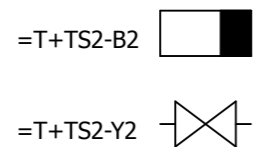
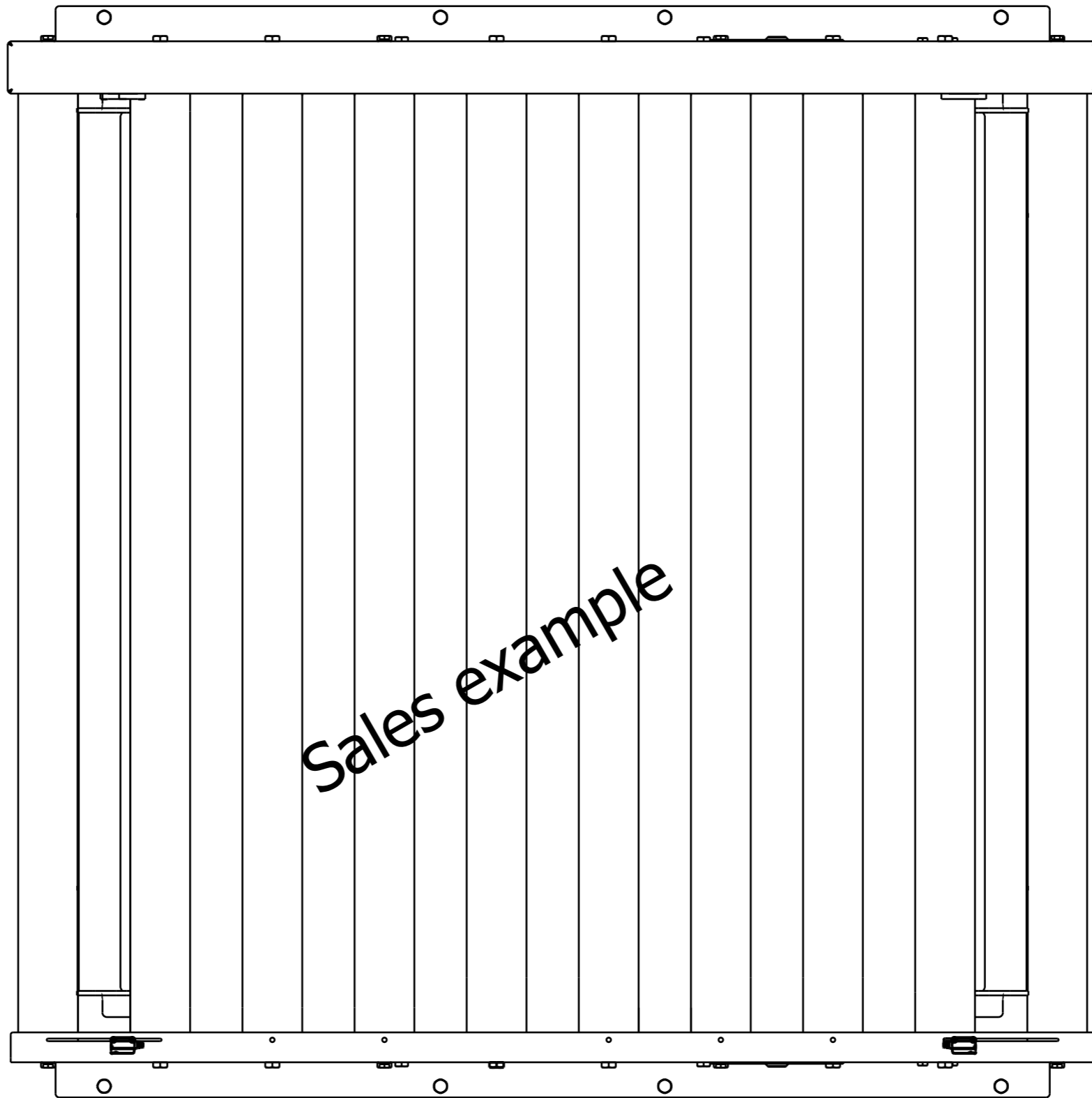

**LEGEND:**

- =T+T-B1 PROTECTION CARRIER NOT FREE 1
- =T+T-B1-W1 1 m PVC-OB 4x0,25mm2
- =T+T-B2 PROTECTION CARRIER NOT FREE 2
- =T+T-B2-W1 1 m PVC-OB 4x0,25mm2
- =T+TS2-B1 TRANSPORTEUR STOPKLEP 1 NEER
- =T+TS2-B1-W1 1 m PVC-OB 4x0,34mm2
- =T+TS2-Y1 AANSTURING TRANSPORTEUR STOPKLEP 1 NEER
- =T+TS2-Y1-W1 0,3 m PVC-OB 3x0,25mm2
- =T+TS2-Y1-W2 1 m PVC-OB 4x0,34mm2
- =T+TS2-B2 TRANSPORTEUR STOPKLEP 2 NEER
- =T+TS2-B2-W1 1 m PVC-OB 4x0,34mm2
- =T+TS2-Y2 AANSTURING TRANSPORTEUR STOPKLEP 2 NEER
- =T+TS2-Y2-W1 0,3 m PVC-OB 3x0,25mm2
- =T+TS2-Y2-W2 1 m PVC-OB 4x0,34mm2
  
- =D+D-U1 CONNECTION UNIT CARRIER PRORUNNER MK10
- =T+TS2-U1 AANSLUIT UNIT TRANSPORTEUR 2 STOPKLEPPEN

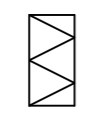

=T+T-B1

=D+D-U1

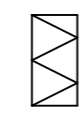

=T+T-B2

Sales example

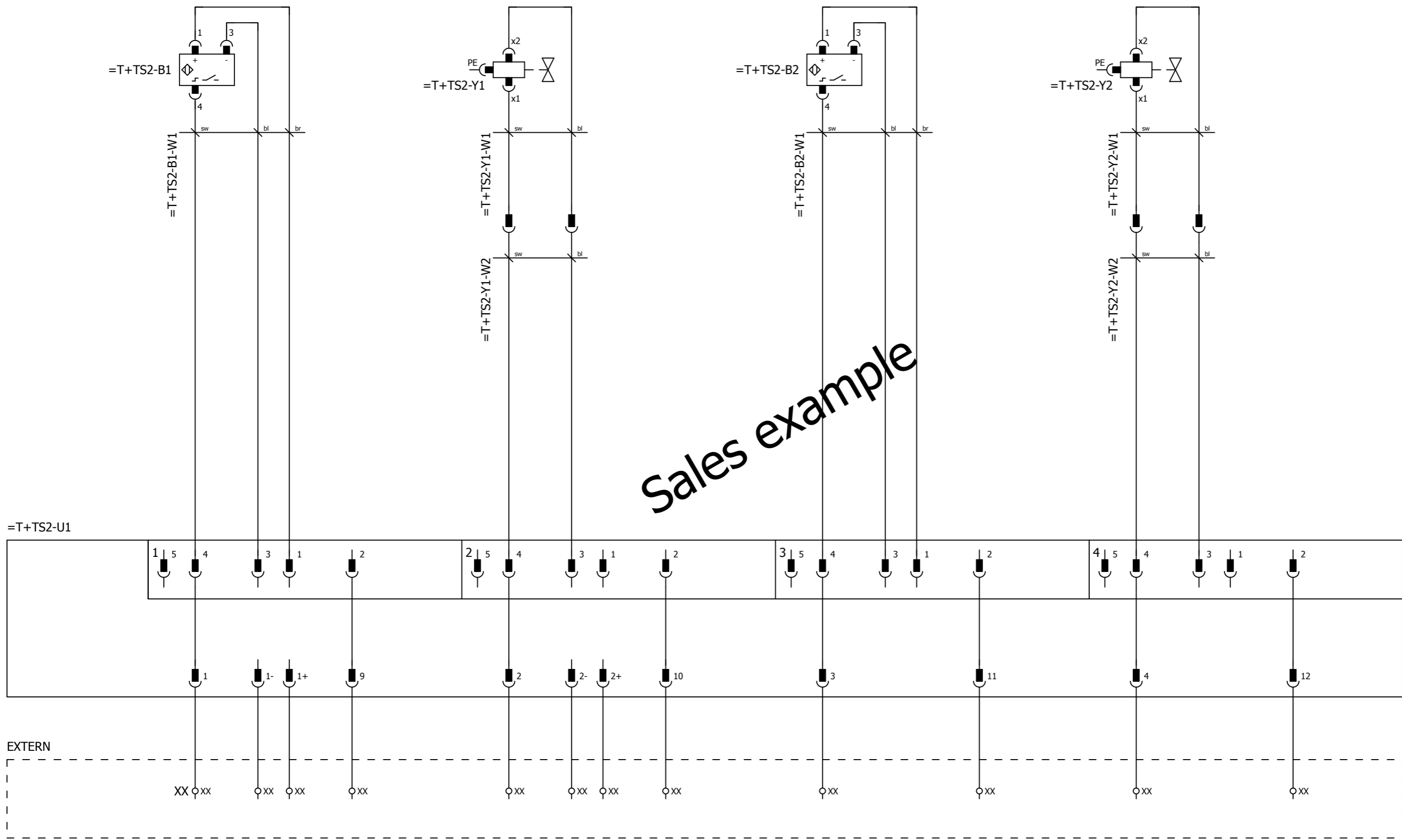

AANSLUIT UNIT TRANSPORTEUR 2 STOPKLEPPEN	TRANSPORTEUR STOPKLEP 1 NEER	SPARE	AANSTURING TRANSPORTEUR STOPKLEP 1 NEER	SPARE	TRANSPORTEUR STOPKLEP 2 NEER	SPARE	AANSTURING TRANSPORTEUR STOPKLEP 2 NEER	SPARE
--	------------------------------------	-------	--	-------	------------------------------------	-------	--	-------



Sales example

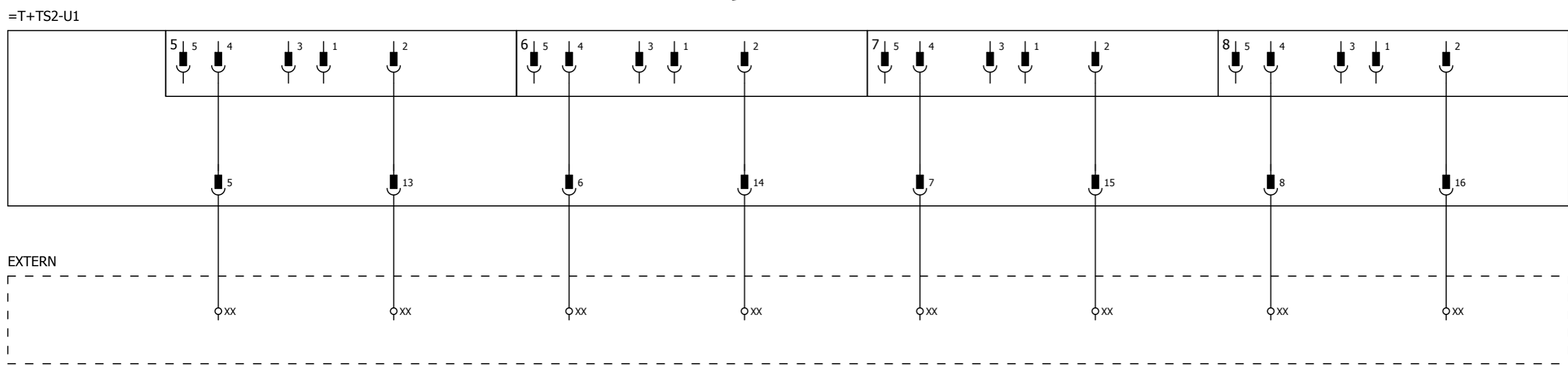

AANSLUIT UNIT TRANSPORTEUR 2 STOPKLEPPEN

SPARE SPARE SPARE SPARE SPARE SPARE SPARE SPARE

# Parts list

Position	Quantity	Article number	Discription
-B1	1	1005354	Reed contact, connector M12
-B1-W1	1	1001601	Prefab cable, PVC, 1 meter, connector M12 male 90°+ M12 female 90°, 4-pole
-B2	1	1005354	Reed contact, connector M12
-B2-W1	1	1001601	Prefab cable, PVC, 1 meter, connector M12 male 90°+ M12 female 90°, 4-pole
-U1	1	1003309	Connection unit, 8-fold, 5-pole, M12
-Y1	1		Coil see mechanical part list
-Y1-W1	1	1005959	Prefab cable, PVC, 0,3 meter, connector M12 male + female M8 straight 90°, 3-pole
-Y1-W2	1	1001601	Prefab cable, PVC, 1 meter, connector M12 male 90°+ M12 female 90°, 4-pole
-Y2	1		Coil see mechanical part list
-Y2-W1	1	1005959	Prefab cable, PVC, 0,3 meter, connector M12 male + female M8 straight 90°, 3-pole
-Y2-W2	1	1001601	Prefab cable, PVC, 1 meter, connector M12 male 90°+ M12 female 90°, 4-pole

Sales example



Nobelstraat 43  
3846 CE Harderwijk  
The Netherlands

Phone: +31 341 - 436700  
Fax: +31 341 - 436701  
www.qimarox.com  
info@qimarox.com

Mounting group:        =T            Conveyor on carrier

Mounting location:    +TSC2        Transporteur + 2 stopkleppen + centrering

Sales example

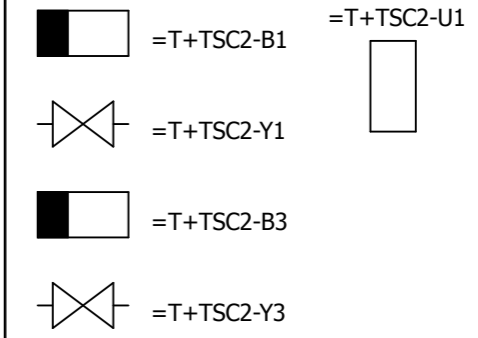
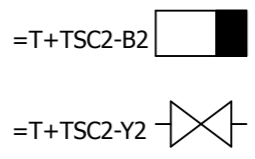
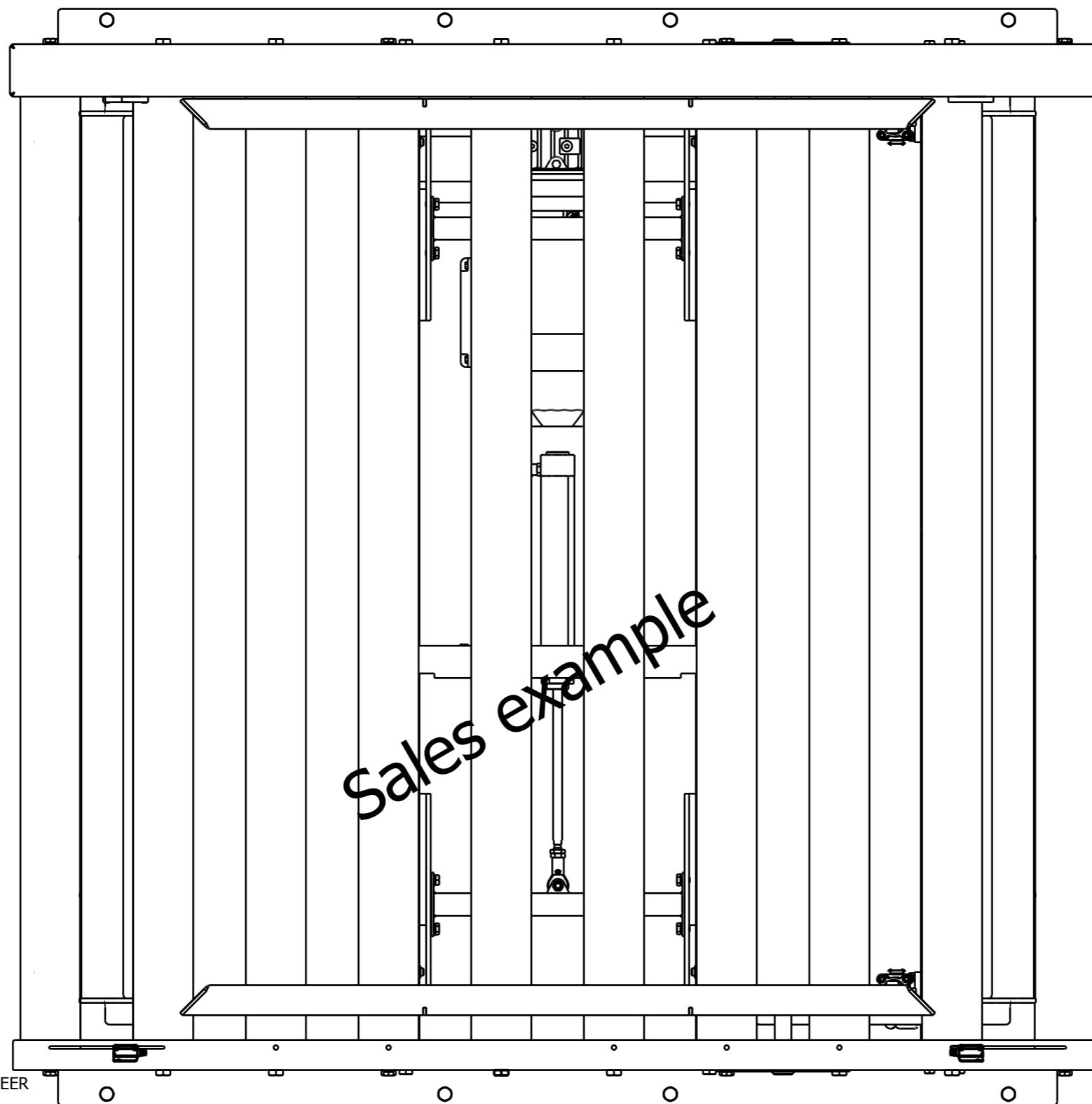

**LEGEND:**

- =T+T-B1 PROTECTION CARRIER NOT FREE 1
- =T+T-B1-W1 1 m PVC-OB 4x0,25mm2
- =T+T-B2 PROTECTION CARRIER NOT FREE 2
- =T+T-B2-W1 1 m PVC-OB 4x0,25mm2
- =T+TSC2-B1 TRANSPORTEUR STOPKLEP 1 NEER
- =T+TSC2-B1-W1 1 m PVC-OB 4x0,34mm2
- =T+TSC2-Y1 AANSTURING TRANSPORTEUR STOPKLEP 1 NEER
- =T+TSC2-Y1-W1 0,3 m PVC-OB 3x0,25mm2
- =T+TSC2-Y1-W2 1 m PVC-OB 4x0,34mm2
- =T+TSC2-B2 TRANSPORTEUR STOPKLEP 2 NEER
- =T+TSC2-B2-W1 1 m PVC-OB 4x0,34mm2
- =T+TSC2-Y2 AANSTURING TRANSPORTEUR STOPKLEP 2 NEER
- =T+TSC2-Y2-W1 0,3 m PVC-OB 3x0,25mm2
- =T+TSC2-Y2-W2 1 m PVC-OB 4x0,34mm2
- =T+TSC2-B3 TRANSPORTEUR CENTRERING GEOPEND
- =T+TSC2-B3-W1 1 m PVC-OB 4x0,34mm2
- =T+TSC2-Y3 AANSTURING TRANSPORTEUR CENTRERING SLUITEN
- =T+TSC2-Y3-W1 0,3 m PVC-OB 3x0,25mm2
- =T+TSC2-Y3-W2 1 m PVC-OB 4x0,34mm2
  
- =D+D-U1 CONNECTION UNIT CARRIER PRORUNNER MK10
- =T+TSC2-U1 AANSLUIT UNIT TRANSPORTEUR 2 STOPKLEPPEN + CENTRERING

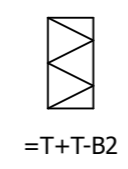
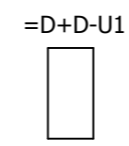
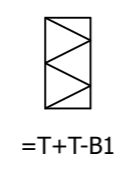

Sales example

Sales example

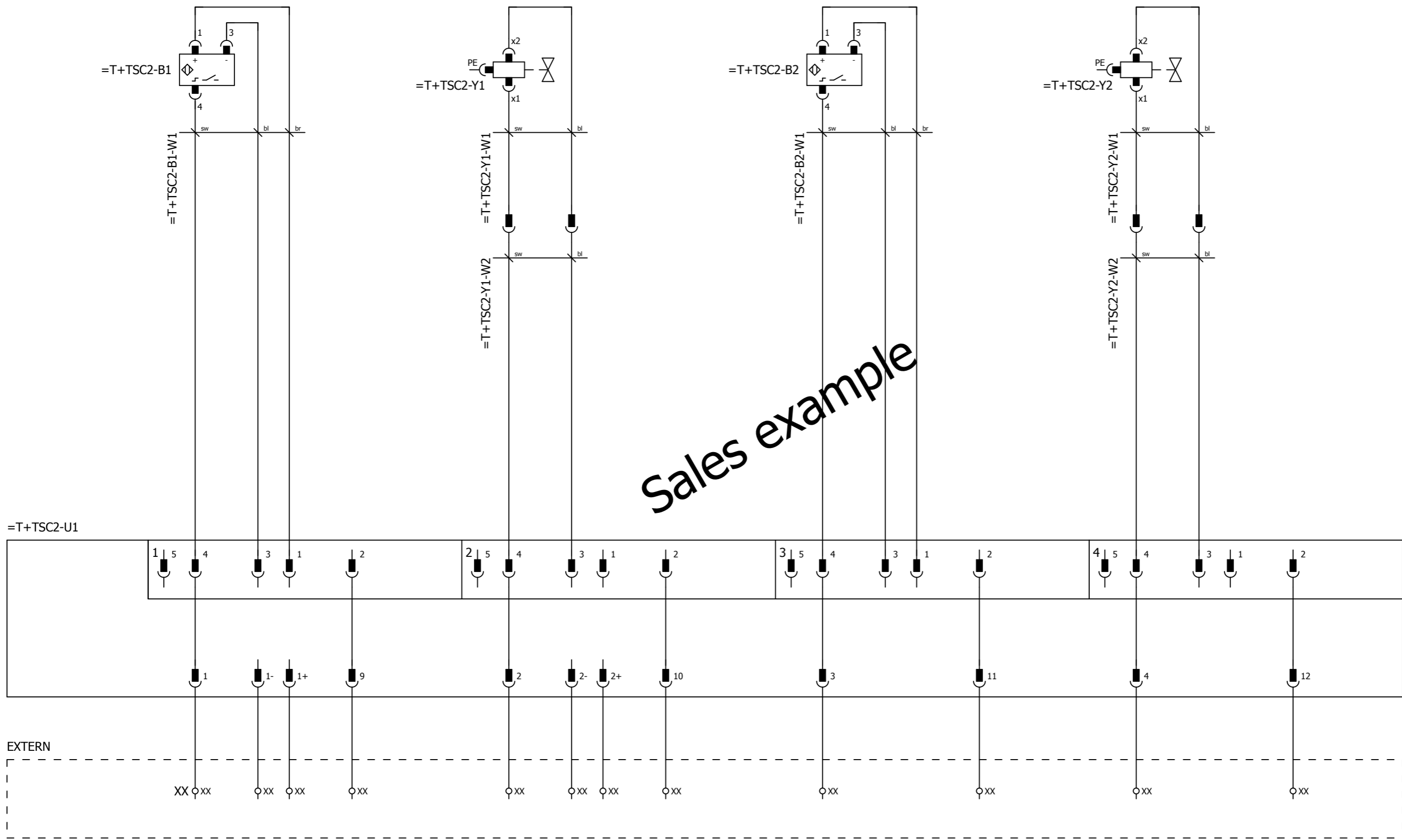

AANSLUIT UNIT TRANSPORTEUR 2 STOPKLEPPEN + CENTRERING	TRANSPORTEUR STOPKLEP 1 NEER	SPARE	AANSTURING TRANSPORTEUR STOPKLEP 1 NEER	SPARE	TRANSPORTEUR STOPKLEP 2 NEER	SPARE	AANSTURING TRANSPORTEUR STOPKLEP 2 NEER	SPARE
---	------------------------------------	-------	--	-------	------------------------------------	-------	--	-------

Sales example

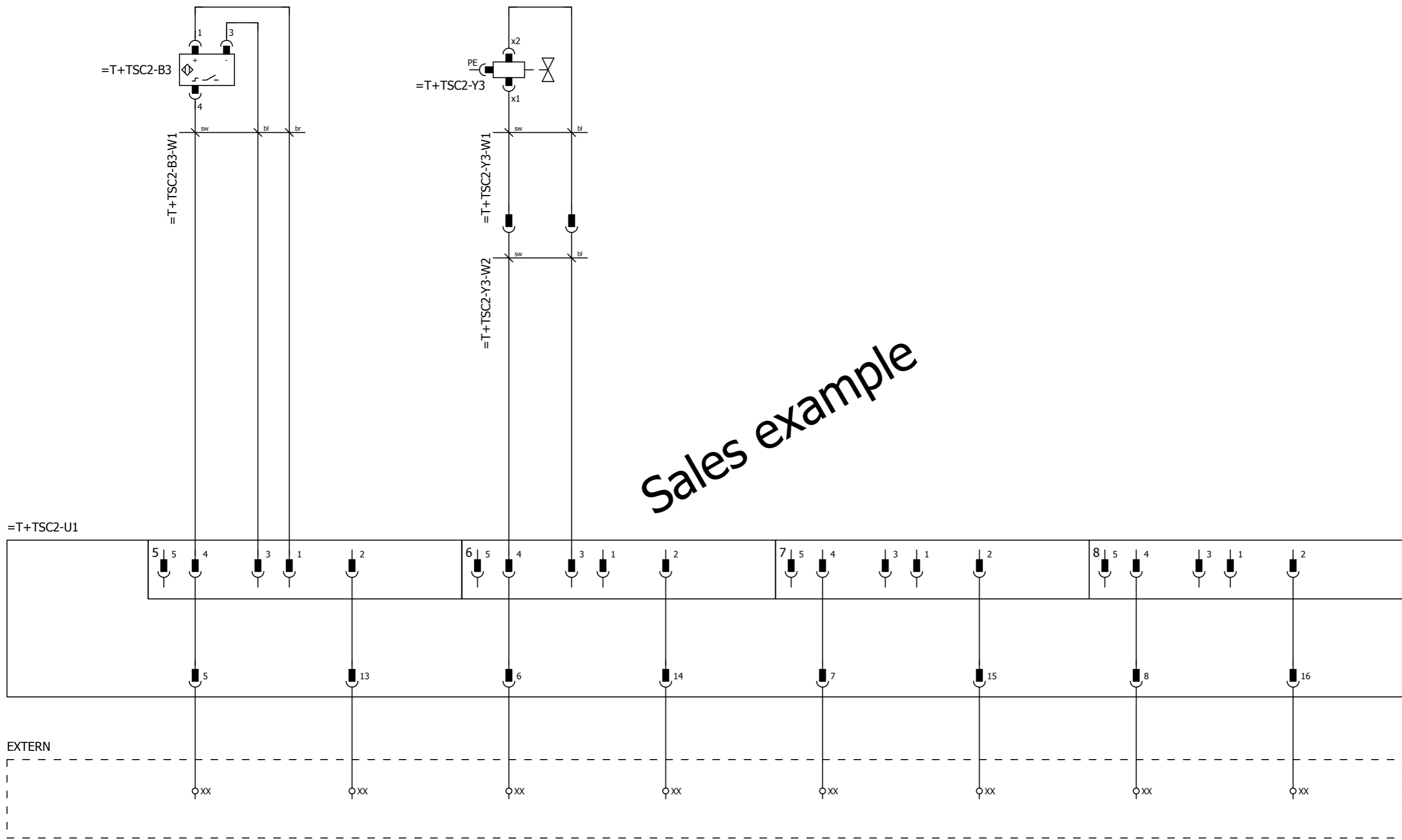

- AANSLUIT UNIT
- TRANSPORTEUR
- 2 STOPKLEPPEN + CENTRERING
- TRANSPORTEUR
- CENTRERING
- GEOPEND
- SPARE
- AANSTURING
- TRANSPORTEUR
- CENTRERING
- SLUITEN
- SPARE
- SPARE
- SPARE
- SPARE
- SPARE

# Parts list

Position	Quantity	Article number	Discription
-B1	1	1005354	Reed contact, connector M12
-B1-W1	1	1001601	Prefab cable, PVC, 1 meter, connector M12 male 90°+ M12 female 90°, 4-pole
-B2	1	1005354	Reed contact, connector M12
-B2-W1	1	1001601	Prefab cable, PVC, 1 meter, connector M12 male 90°+ M12 female 90°, 4-pole
-B3	1	1005354	Reed contact, connector M12
-B3-W1	1	1001601	Prefab cable, PVC, 1 meter, connector M12 male 90°+ M12 female 90°, 4-pole
-U1	1	1003309	Connection unit, 8-fold, 5-pole, M12
-Y1	1		Coil see mechanical part list
-Y1-W1	1	1005959	Prefab cable, PVC, 0,3 meter, connector M12 male + female M8 straight 90°, 3-pole
-Y1-W2	1	1001601	Prefab cable, PVC, 1 meter, connector M12 male 90°+ M12 female 90°, 4-pole
-Y2	1		Coil see mechanical part list
-Y2-W1	1	1005959	Prefab cable, PVC, 0,3 meter, connector M12 male + female M8 straight 90°, 3-pole
-Y2-W2	1	1001601	Prefab cable, PVC, 1 meter, connector M12 male 90°+ M12 female 90°, 4-pole
-Y3	1		Coil see mechanical part list
-Y3-W1	1	1005959	Prefab cable, PVC, 0,3 meter, connector M12 male + female M8 straight 90°, 3-pole
-Y3-W2	1	1001601	Prefab cable, PVC, 1 meter, connector M12 male 90°+ M12 female 90°, 4-pole

Sales example