

# Multi-purpose Frame WM Line

Assembly Guide



# Support multifonctionnel Ligne WM

Guide d'assemblage

- First check the contents.
- Read instructions carefully.
- Save this document for future reference.

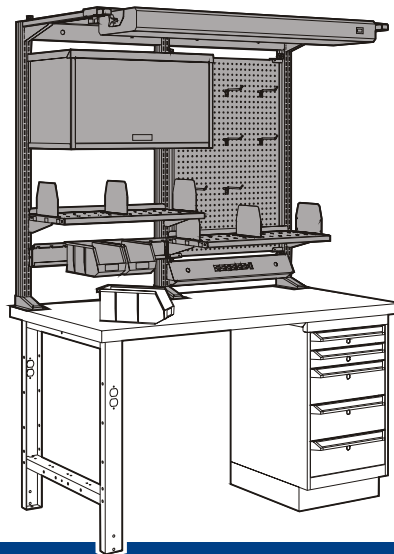

- Commencez par vérifier le contenu.
- Lisez attentivement les instructions.
- Conservez ces instructions pour référence future.

## Tools Required

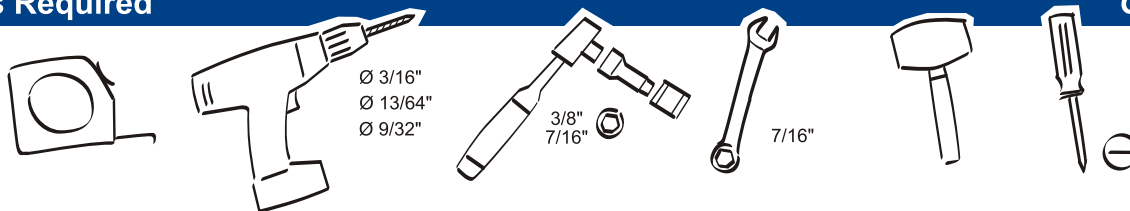

## Outils requis

## Warning

## Mise en garde

### Multi-purpose frame configuration Agencement des montants multifonctionnels

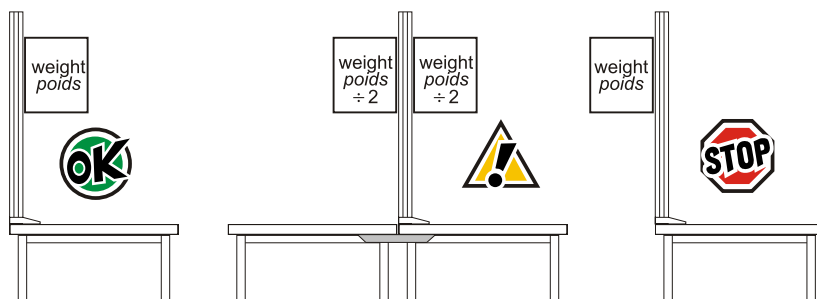

### Maximum load capacity (weight) Capacité de chargement maximum (poids)

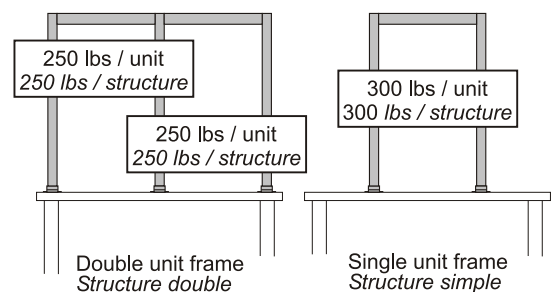

## LEGEND

- Work station stability is safe.
- You must be sure that your work station is stable before using it. If needed, you can anchor it to the wall or to the floor, or attach it to another work station in a back-to-back installation.
- This configuration is not recommended.

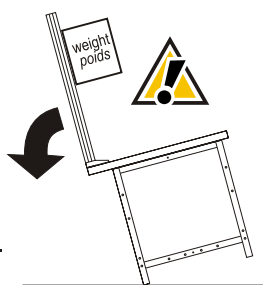

## LÉGENDE

- Poste de travail sécuritaire.
- Vous devez vérifier la stabilité de votre poste de travail avant l'utilisation. Si requis, vous pouvez fixer votre poste de travail au sol, sur un mur ou avec un autre poste dos-à-dos.
- Cet agencement n'est pas recommandé.

**1** Locate the center of top.

**1** Repérer le centre de votre dessus.

**2** Mark the position of uprights, according to the type of frame (see below).

**2** Selon le type de structure, marquer l'emplacement des montants (voir ci-dessous).

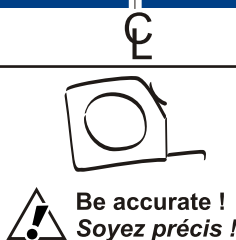

**Single unit frame (2 uprights)**  
**Structure simple (2 montants)**

**Double unit frame (3 uprights)**  
**Structure double (3 montants)**

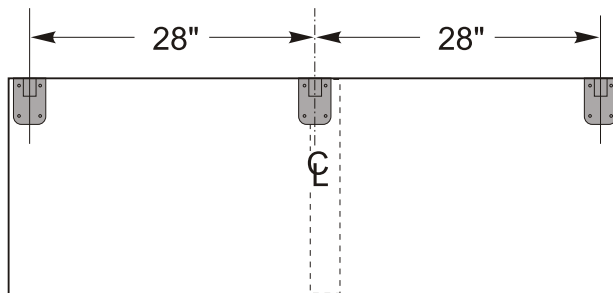
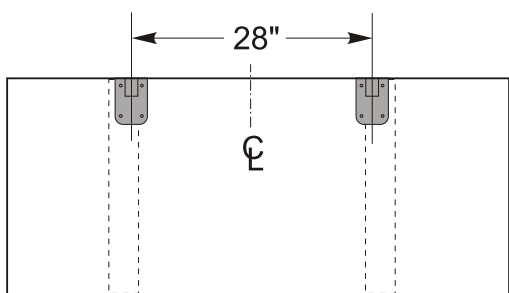

**Steel top**

**Dessus acier**

- You must add a cross bar **under** each upright.

- Vous devez placer une traverse **sous** chaque montant.

**Steel top**

**Dessus acier**

- You must add a cross bar **under center upright**.

- Vous devez placer une traverse **sous le montant** du centre.

**Frame with WS50 steel shelf**  
**Structure avec tablette WS50**

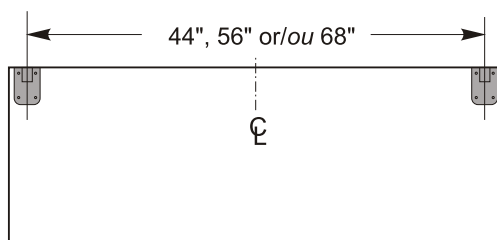

The WM45-48 light and WM components that are on 28" centers are not compatible with the 48" and 72" wide WS50 shelves.

Le luminaire WM45-48 et les autres composants WM de 28" c/c ne sont pas compatibles avec les agencements avec tablettes WS50 de 48" et 72".

**3** Mark the position of holes.

**3** Marquer l'emplacement des trous.

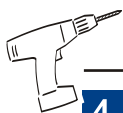
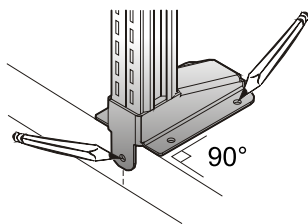

**4** Drill holes for 1" screws

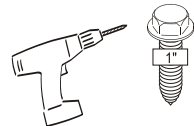

**Without WM14 top reinforcer / Sans renfort de dessus WM14**

Ø 13/64" for steel top / pour dessus en acier  
Ø 3/16" for other top / pour les autres dessus

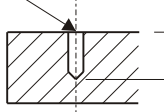

1" Deep for laminated top / de profond pour dessus en stratifié  
3/8" Deep for laminated top / de profond pour dessus en stratifié

**4** Percer les trous pour vis de 1"

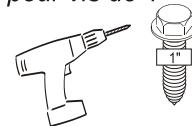

**With WM14 top reinforcer / Avec renfort de dessus WM14**

Ø 9/32"



For all top / Pour tous les dessus



**STAINLESS STEEL drilling** : The speed revolution of the drill must be considerably reduced when drilling a stainless steel worksurface to avoid damage to drill bits. It is recommended to use vinegar or tapping compound.

**Perçage de l'ACIER INOXYDABLE** : La vitesse de révolution d'une perceuse pour le perçage d'une surface de travail en acier inoxydable doit être considérablement réduite afin de ne pas endommager le forêt de perçage. Il est même recommandé d'utiliser du vinaigre ou un liquide de refroidissement de coupe ("tapping compound").

## Uprights assembly

## Assemblage des montants

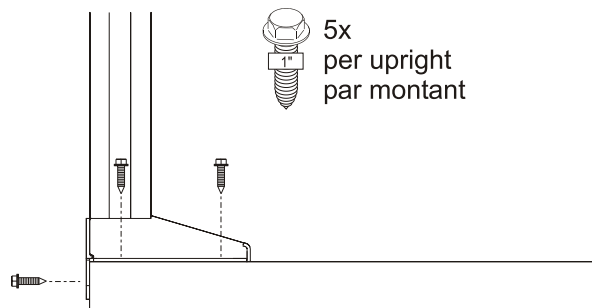
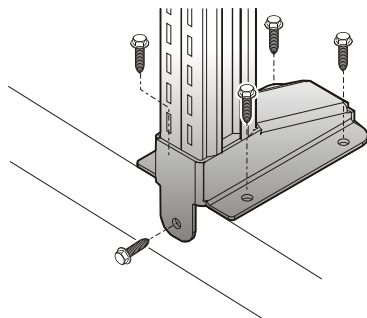

**Laminated top :** The screws mustn't be overtightened to avoid thread strip off.  
**Dessus en stratifié :** Ne pas trop serrer les vis pour éviter que les filets arrachent.

## Top reinforce WM14

## Renfort de dessus WM14

- Required for work tops less than 1 ½" thick, or tops in poor condition, or for back-to-back stations.
- Recommended for work tops other than Rousseau.
- All screws must be installed.

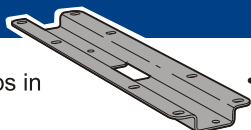

- Requis pour les dessus de postes de travail de moins de 1 ½" ou en mauvais état, ou les postes de travail en utilisation dos-à-dos.
- Recommandé pour tous les dessus non vendus par Rousseau.
- Toutes les vis doivent être installées.

### Case 1

### Cas 1

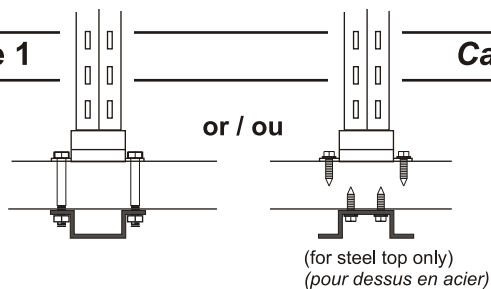

or / ou

(for steel top only)  
(pour dessus en acier)

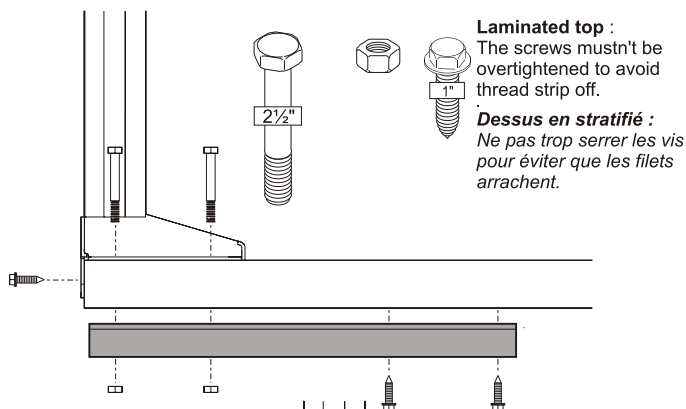

Back-to-back work stations  
Postes de travail dos-à-dos

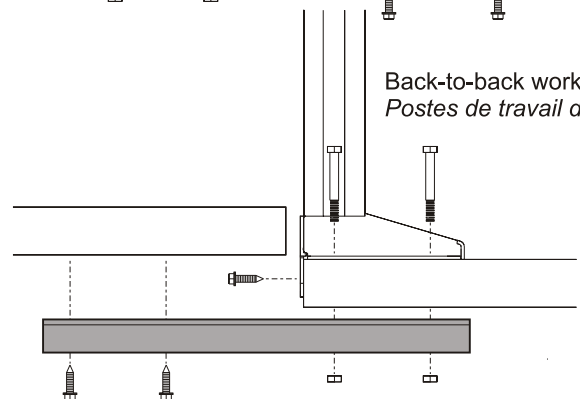

### Case 2

### Cas 2

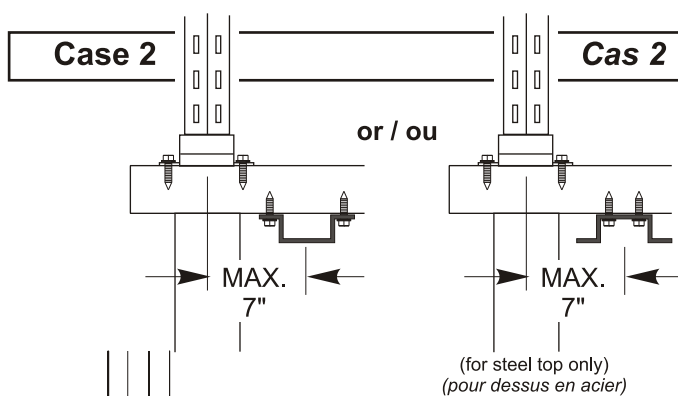

or / ou

(for steel top only)  
(pour dessus en acier)

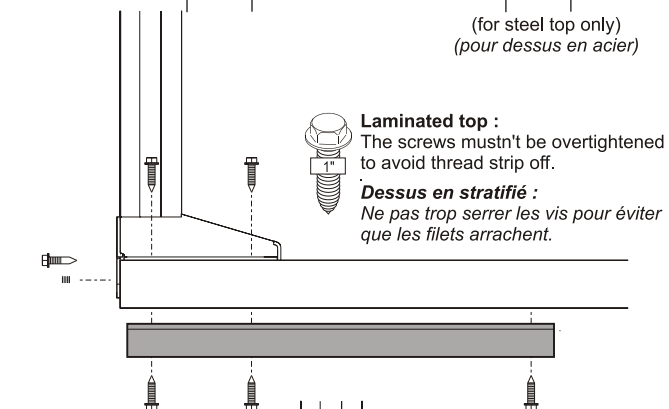

Back-to-back work stations  
Postes de travail dos-à-dos

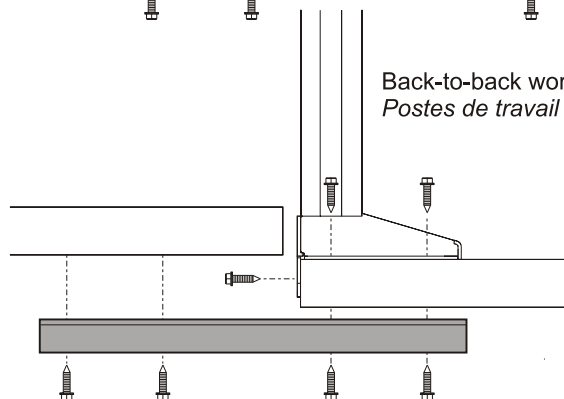

## Upright Crossmember WM15

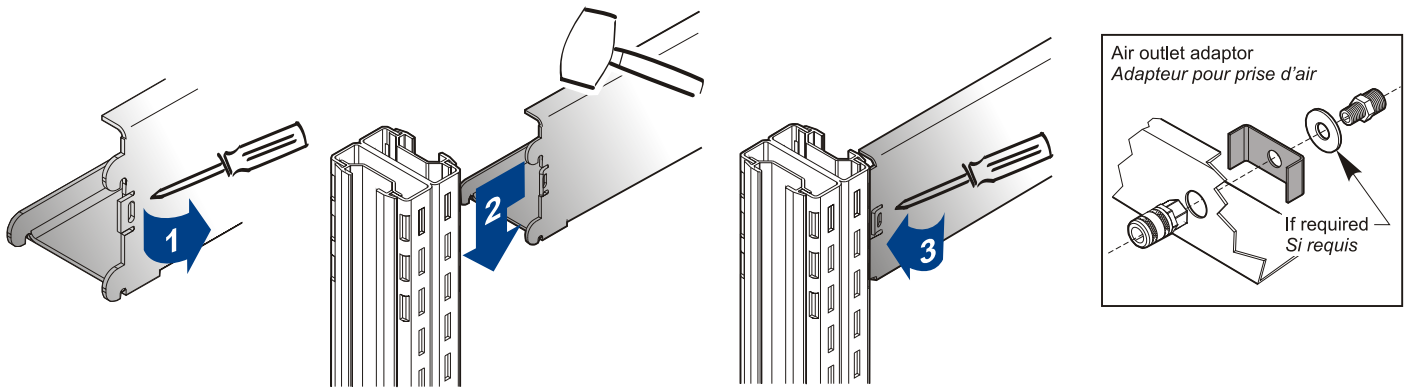

## Tiltable shelf WM20

## Tablette inclinable WM20

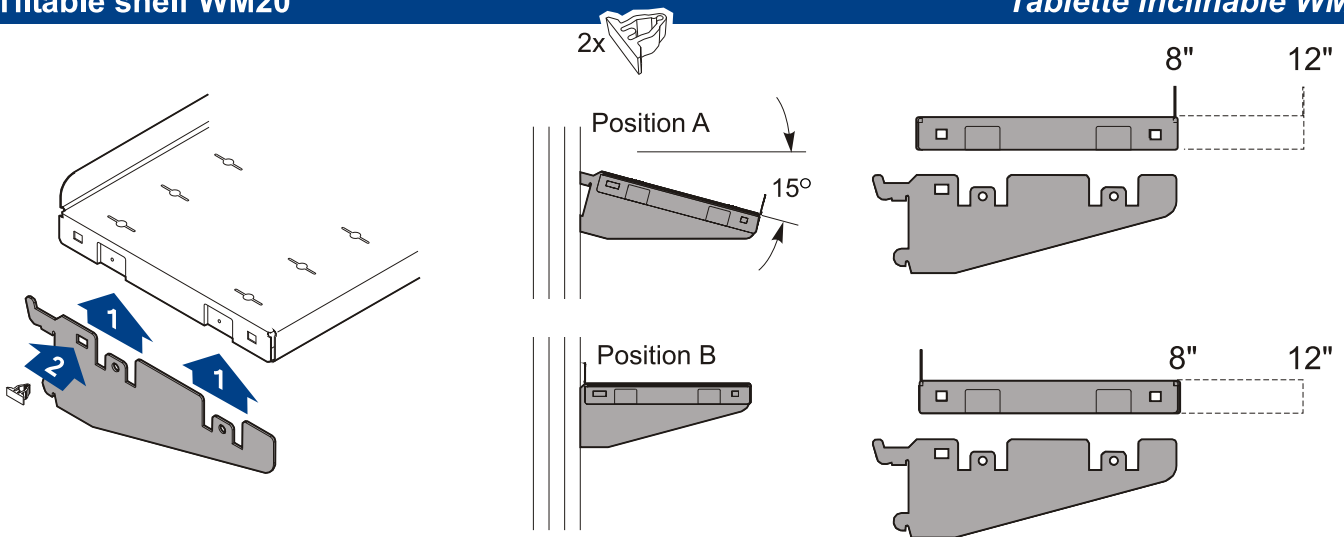

## Plastic bin rail WM28

## Support pour boîte en plastique WM28

