

Tech Uprights & Accessories R Line

Assembly Guide



Poteaux de soutien & accessoires Ligne R

Guide d'assemblage

- All required hardware is included.
- Please check the contents with your packing slip.
- Read instructions carefully.
- Save this document for future reference.
- Two people are required for the assembly.

- Toute la quincaillerie requise est incluse.
- Veuillez vérifier le contenu avec votre feuille de livraison.
- Lisez attentivement les instructions.
- Conservez ces instructions pour référence future.
- Deux personnes sont requises pour l'assemblage.

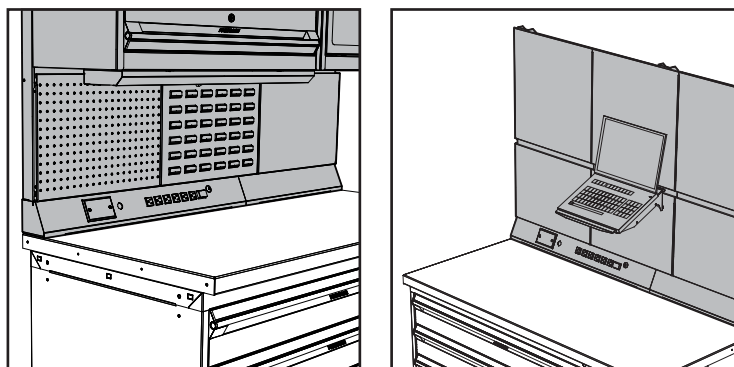

Tools Required

Outils requis

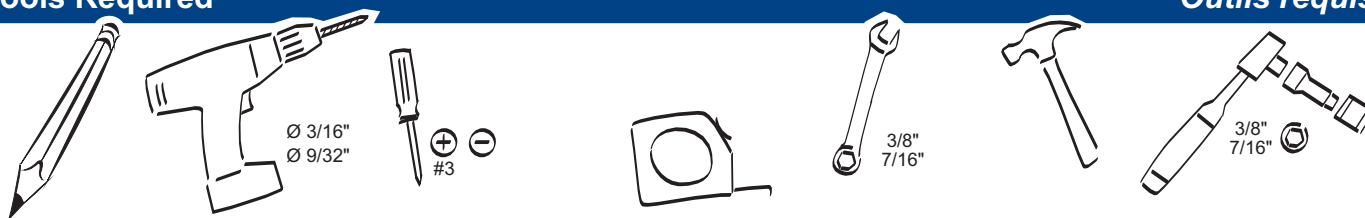

RD44 Tech Upright Assembly

Assemblage poteaux de soutien RD44

1 Place tech uprights according to the type of layout (see below).

1 Selon le type de montage, placer les poteaux de soutien (voir ci-dessous).

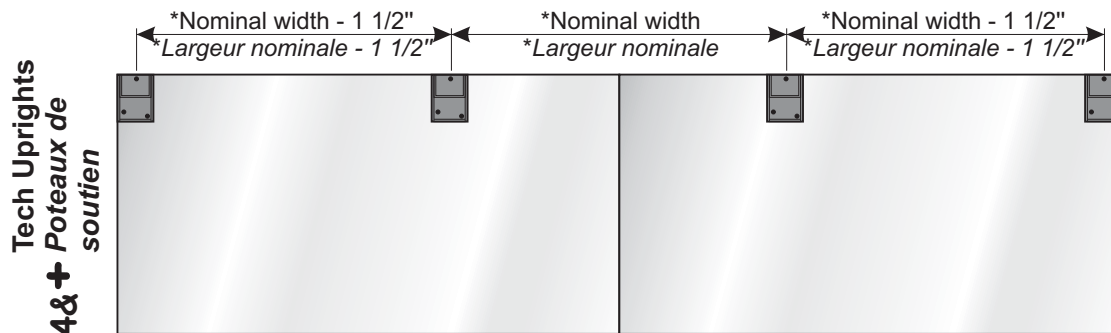
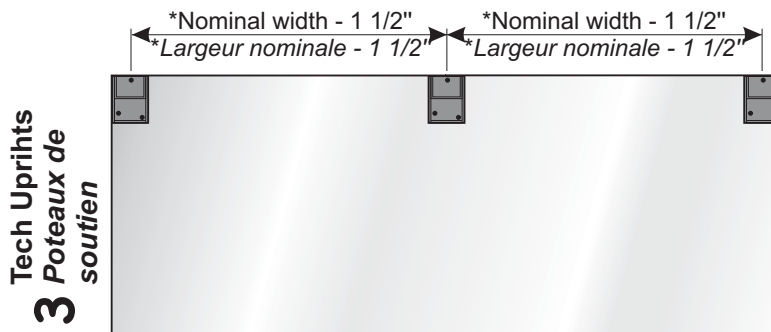
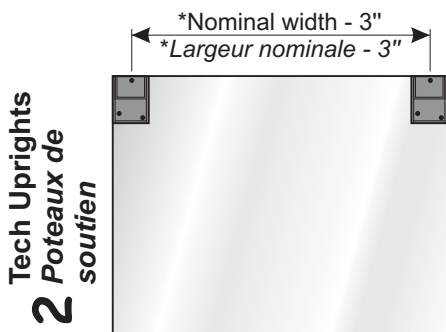

***Nominal width**

= nominal width of cabinets RD02/39 &
= nominal width of brackets RC47 for finishing panels

***Largeur nominale**

= largeur nominale des cabinets RD02/39 &
= largeur nominale des ensembles de fixation RC47 pour panneaux de finition



Note 1

Never assemble one tech upright over two worktops
 Ne jamais assembler de poteau de soutien à la jonction de deux dessus.



Note 2

Max. capacity for cabinet mounted on tech upright :200 lb
 Capacité max. par caisson sur poteau de soutien : 200 lb

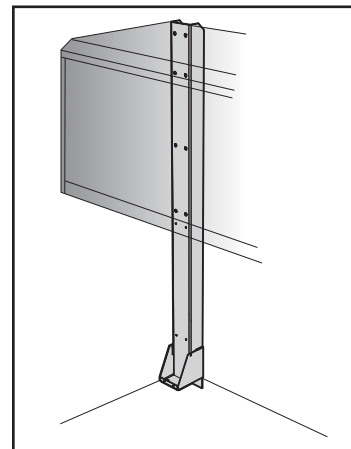
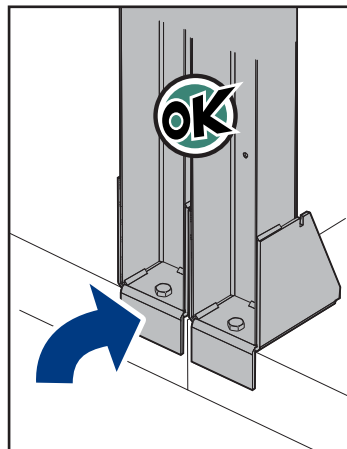
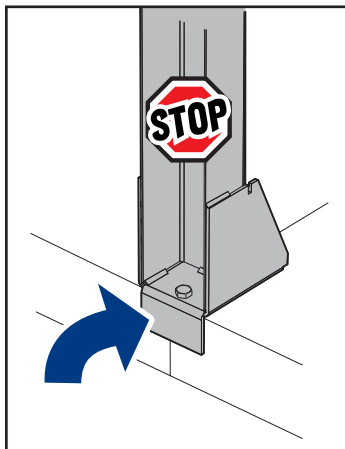

2 Mark the position of holes.
 Marquer l'emplacement des trous.

3 Drill
 Percer

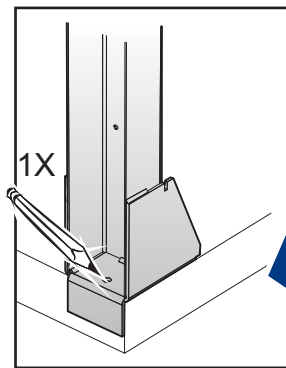
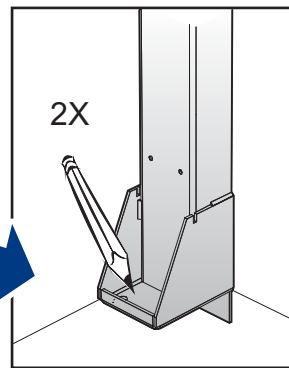
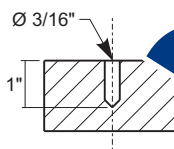

3 Drill
 Percer

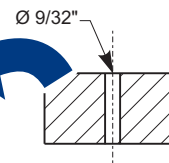

STAINLESS STEEL drilling : The speed revolution of the drill must be considerably reduced when drilling a stainless steel worksurface to avoid damage to drill bits. It is recommended to use tapping compound.

Perçage de l'ACIER INOXYDABLE : La vitesse de révolution d'une perceuse pour le perçage d'une surface de travail en acier inoxydable doit être considérablement réduite afin de ne pas endommager le forêt de perçage. Il est même recommandé d'utiliser un liquide de refroidissement de coupe ("tapping compound").

4 Assembly
 Assemblage

1/4-20 bolts
 Boulons 1/4-20
 3L118362

1/4-20 nuts
 Écrous 1/4-20
 3S1801Z2

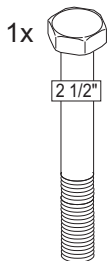

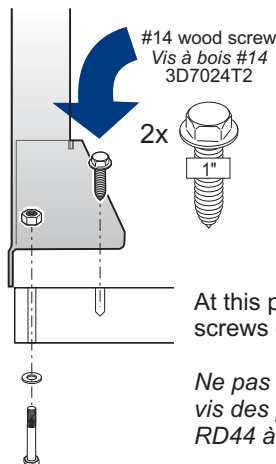

Washer
 Rondelle
 3Z011902

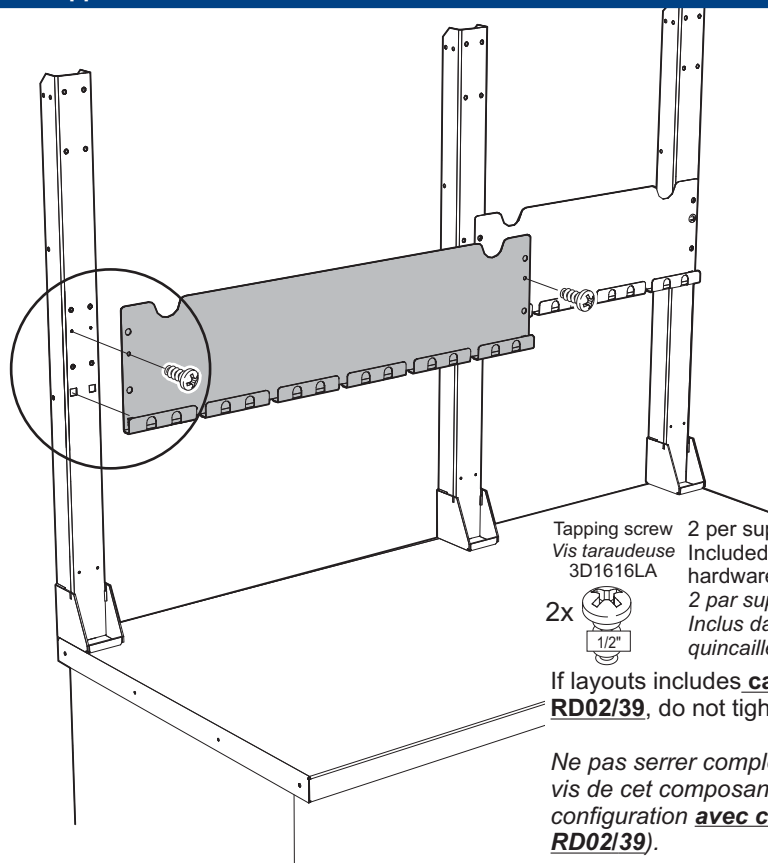
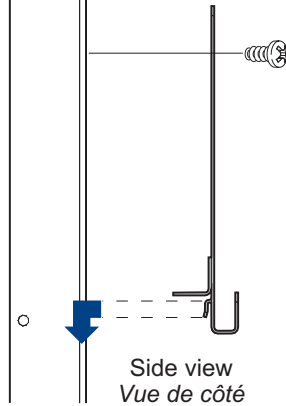
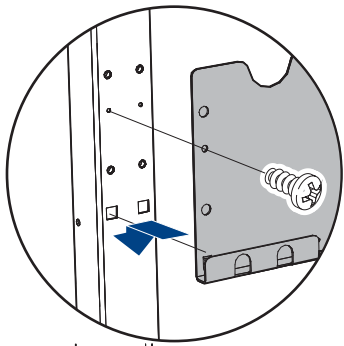

At this point, do not tighten the screws of RD44 tech upright.

Ne pas serrer complètement les vis des poteaux de soutien RD44 à cette étape.



Tapping screw 2 per support
 Vis taraudeuse 3D1616LA Included in RC47Q001 hardware kit
 2x  2 par support
 Inclus dans l'ensemble de quincaillerie RC47Q001

If layouts includes **cabinets RD02/39**, do not tighten screws.

*Ne pas serrer complètement les vis de cet composantes (si configuration **avec cabinets RD02/39**).*

Additional Brackets for layouts without cabinet RD02/39

Fixation supplémentaire pour configuration sans cabinet RD02/39

Completely tighten all screws.
Serrer complètement toutes les vis.

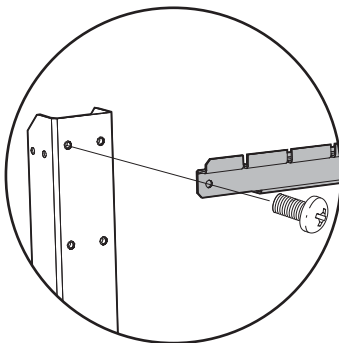

1/4-20 bolts 2 per support
 Boulons 1/4-20 3A1818L2 Included in RC47Q002 hardware kit
 2x  2 par support
 Inclus dans l'ensemble de quincaillerie RC47Q002

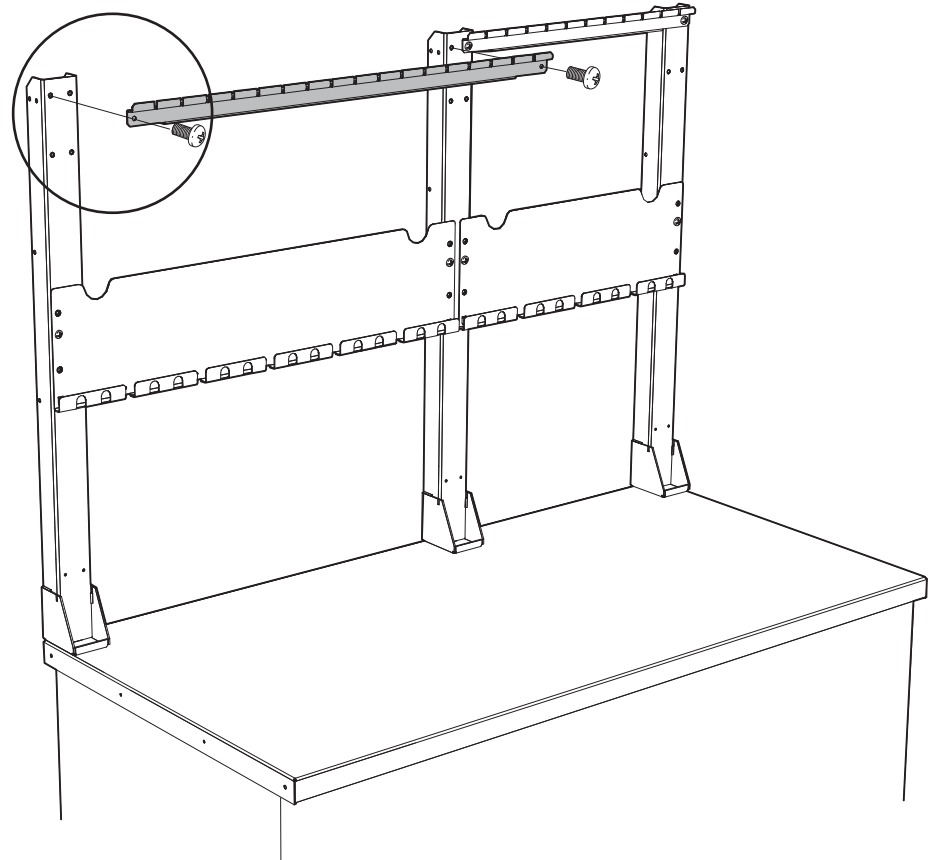

19" Uprights

Poteaux de 19"

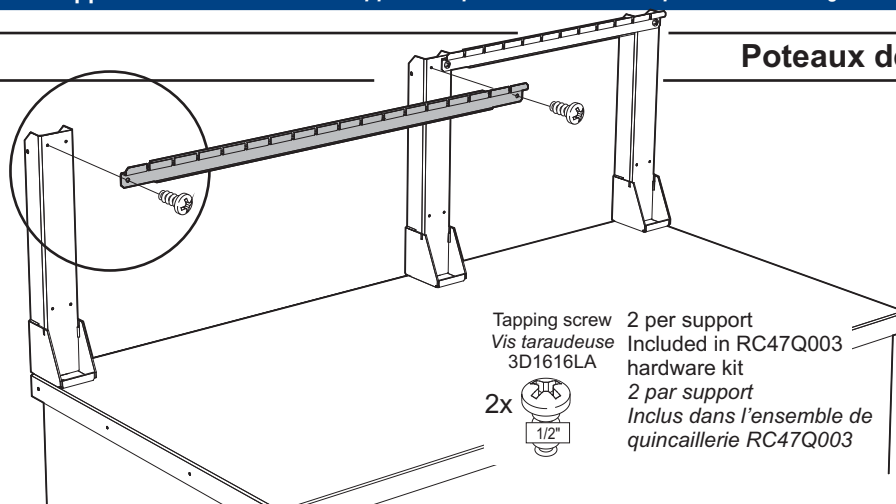
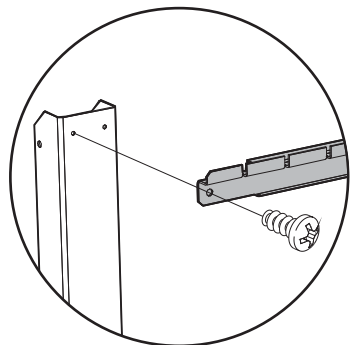

Tapping screw 2 per support
 Vis taraudeuse 3D1616LA Included in RC47Q003 hardware kit
 2 par support
 Inclus dans l'ensemble de quincaillerie RC47Q003



RD02/39 Cabinets Assembly (if required)

Assemblage des cabinets RD02/39 (si requis)

- 1 Put top screws in place as illustrated.
Placer les vis du haut tel qu'illustré.
- 2 Assemble cabinets on tech uprights.
Assembler les cabinets sur les poteaux de soutien.
- 3 Put bottom screws in place.
Placer en place les vis du bas.
- 4 Tighten screws.
Serrer les vis.

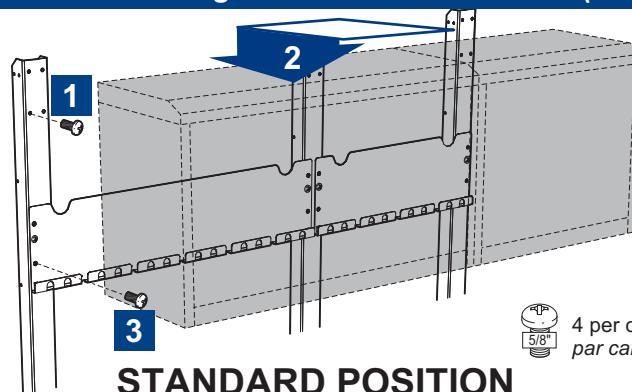

4 per cabinet / par cabinet

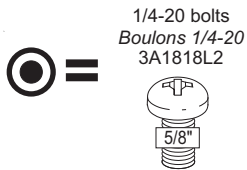

STANDARD POSITION
POSITION STANDARD

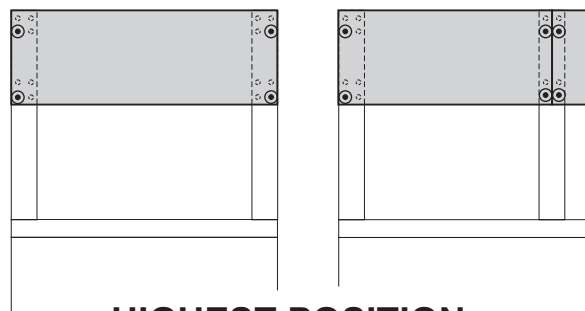

HIGHEST POSITION
POSITION HAUTE +4"

Better visibility and accessibility for taller people.

4" Meilleure visibilité et accessibilité pour personnes plus grandes.

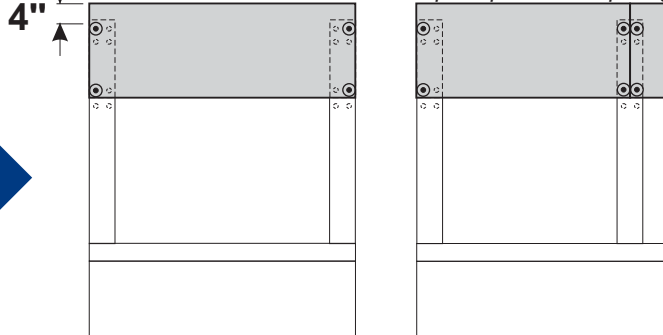

- 5 Completely tighten all screws of the tech uprights RD44 and of the RC47 supports for the finishing/perforated/louvered panels.
Finir de visser les vis des poteaux de soutien RD44 et celles des supports pour panneaux de finition/perforé/accrochage RC47.

Wall Anchoring (for 40" uprights)

Ancrage au mur (pour poteaux de 40")

**Optionnal
(to rigidify the assembly)**

**Optionnel
(pour rigidifier l'assemblage)**



The client is responsible for installing the product in a secure manner to a wall capable of supporting this application, and for determining and using the appropriate anchoring hardware.

Le client a la responsabilité d'installer le produit sécuritairement, à un mur capable de recevoir cette application, et de déterminer et d'utiliser la quincaillerie d'ancrage appropriée.

1/4-20 nuts
Écrous 1/4-20
3S1801Z2

1/4-20 bolts
Boulons 1/4-20
3A1818L2

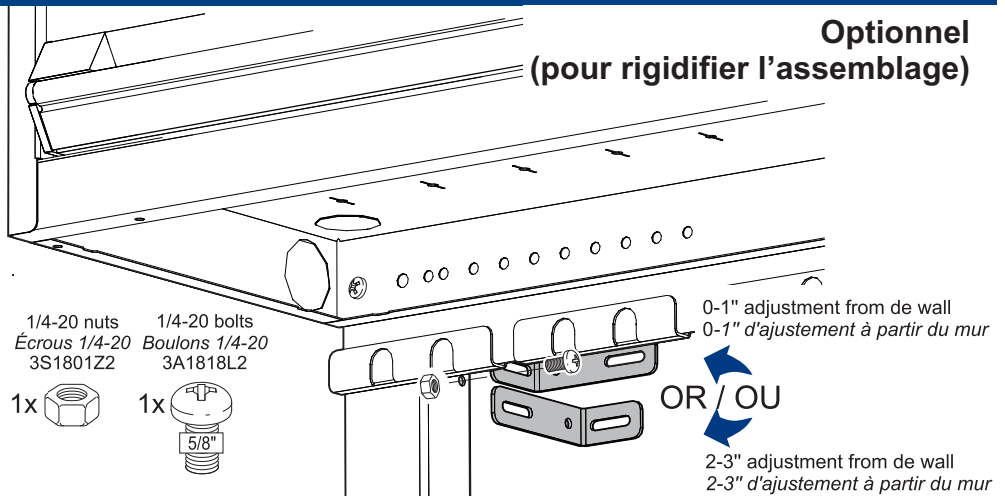

RC6X Power Feed & Cover Panels Assembly

Assemblage modules d'alimentation & finition RC6X

- 1-Position the power feed panel or cover panel in place.
- 2-Mark hole positions:
30" = Only one screw at each extremity (2 screws)
36 & 48" = one screw at each extremity and one screw in the middle (3 screws)
- 3-Remove the power feed panel or cover panel for drilling holes.
- 4-Insert screws in the holes but at this point, do not tighten them.
- 5- Position the power feed panel or cover panel in place.
- 6- Completely tighten all screws.



- 1- Placer le module d'alimentation ou la bande de finition.
- 2- Tracer la position des trous
30" = Seulement une vis à chaque extrémité (2 vis)
36 & 48" = Une vis à chaque extrémité et une au centre (3 vis)
- 3- Retirer le module d'alimentation ou de finition pour percer les trous.
- 4- Placer les vis au préalable mais ne pas les visser complètement.
- 5- Placer le module d'alimentation ou la bande de finition.
- 6- Terminer de vissage.

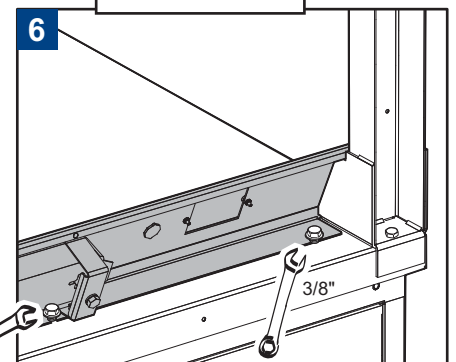
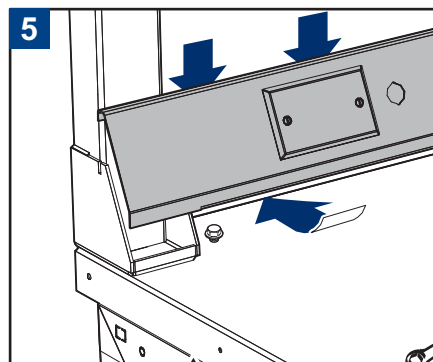
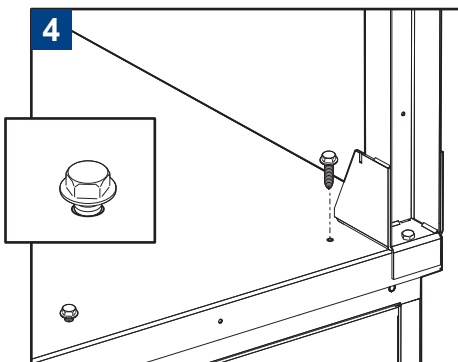
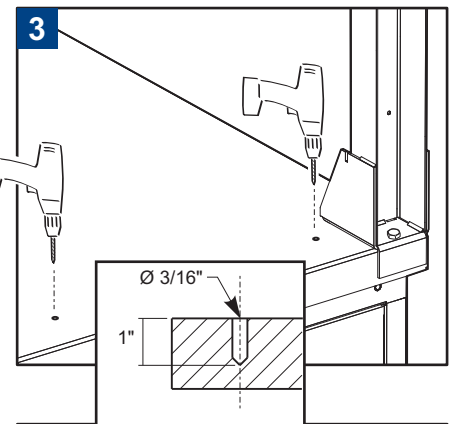
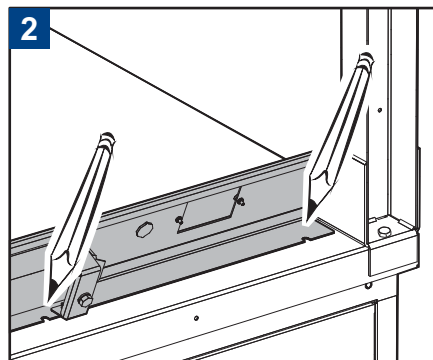
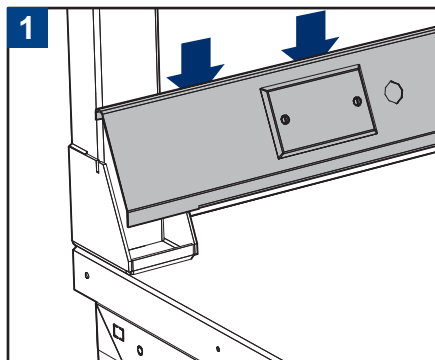

STAINLESS STEEL drilling : The speed revolution of the drill must be considerably reduced when drilling a stainless steel worksurface to avoid damage to drill bits. It is recommended to use tapping compound.

Perçage de l'ACIER INOXYDABLE : La vitesse de révolution d'une perceuse pour le perçage d'une surface de travail en acier inoxydable doit être considérablement réduite afin de ne pas endommager le forêt de perçage. Il est même recommandé d'utiliser un liquide de refroidissement de coupe ("tapping compound").

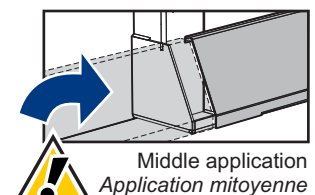

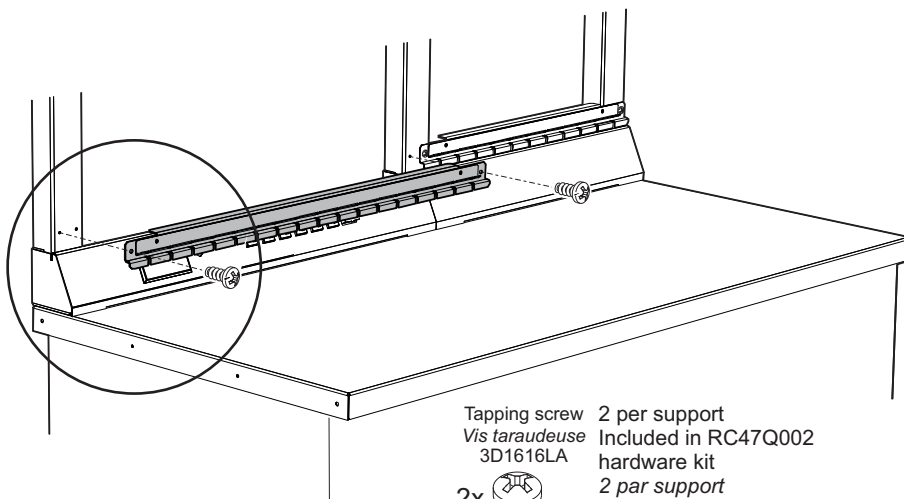
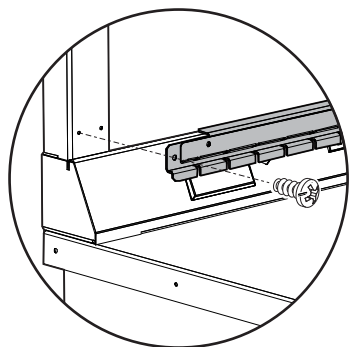

Tapping screw 2 per support
 Vis taraudeuse 3D1616LA Included in RC47Q002 hardware kit
 2x  2 par support
 Inclus dans l'ensemble de quincaillerie RC47Q002

RC4X Finishing/perforated/louvered Panels

Panneaux de finition/perforé/accrochage RC4X

With cabinet RD02/39

Avec cabinet RD02/39

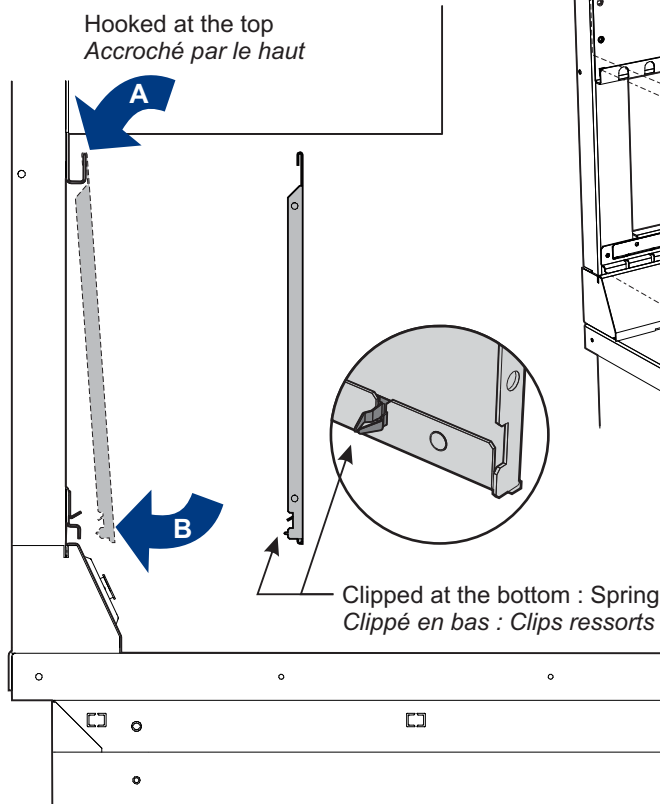

Hooked at the top
 Accroché par le haut

A

B

Clipped at the bottom : Spring clips at the back of the panel
 Clippé en bas : Clips ressorts au dos du panneau

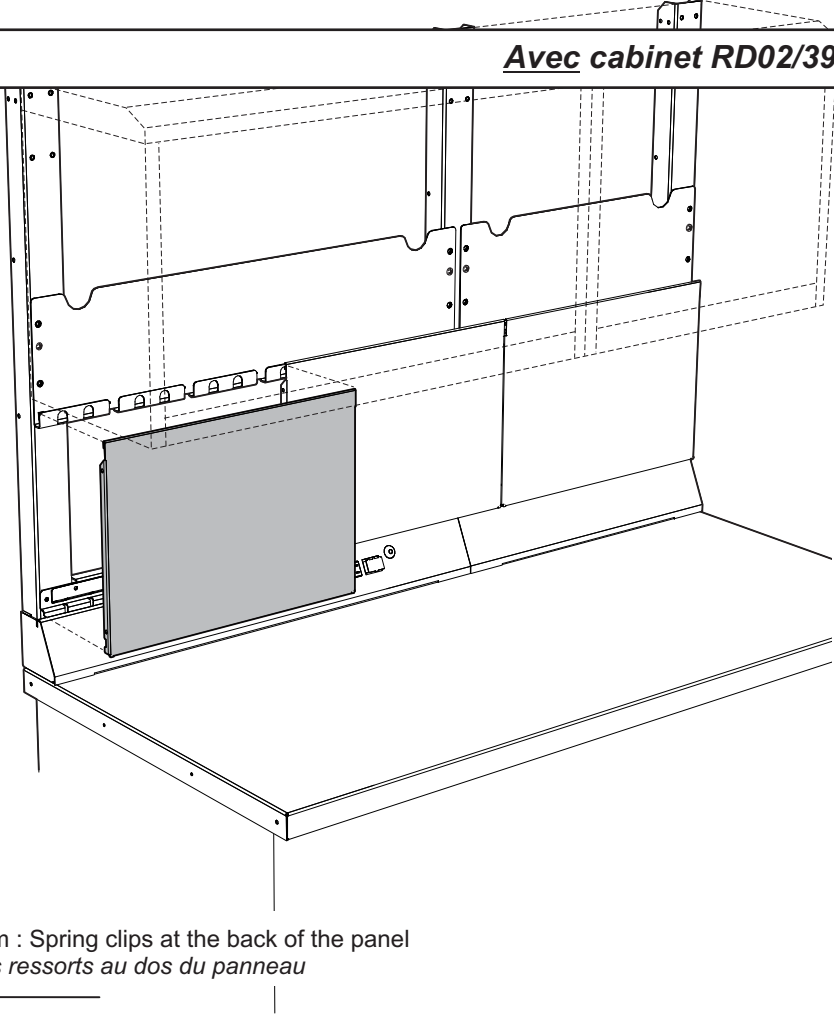

Without cabinet RD02/39 / 40" Uprights

Sans cabinet RD02/39 / Montants 40"

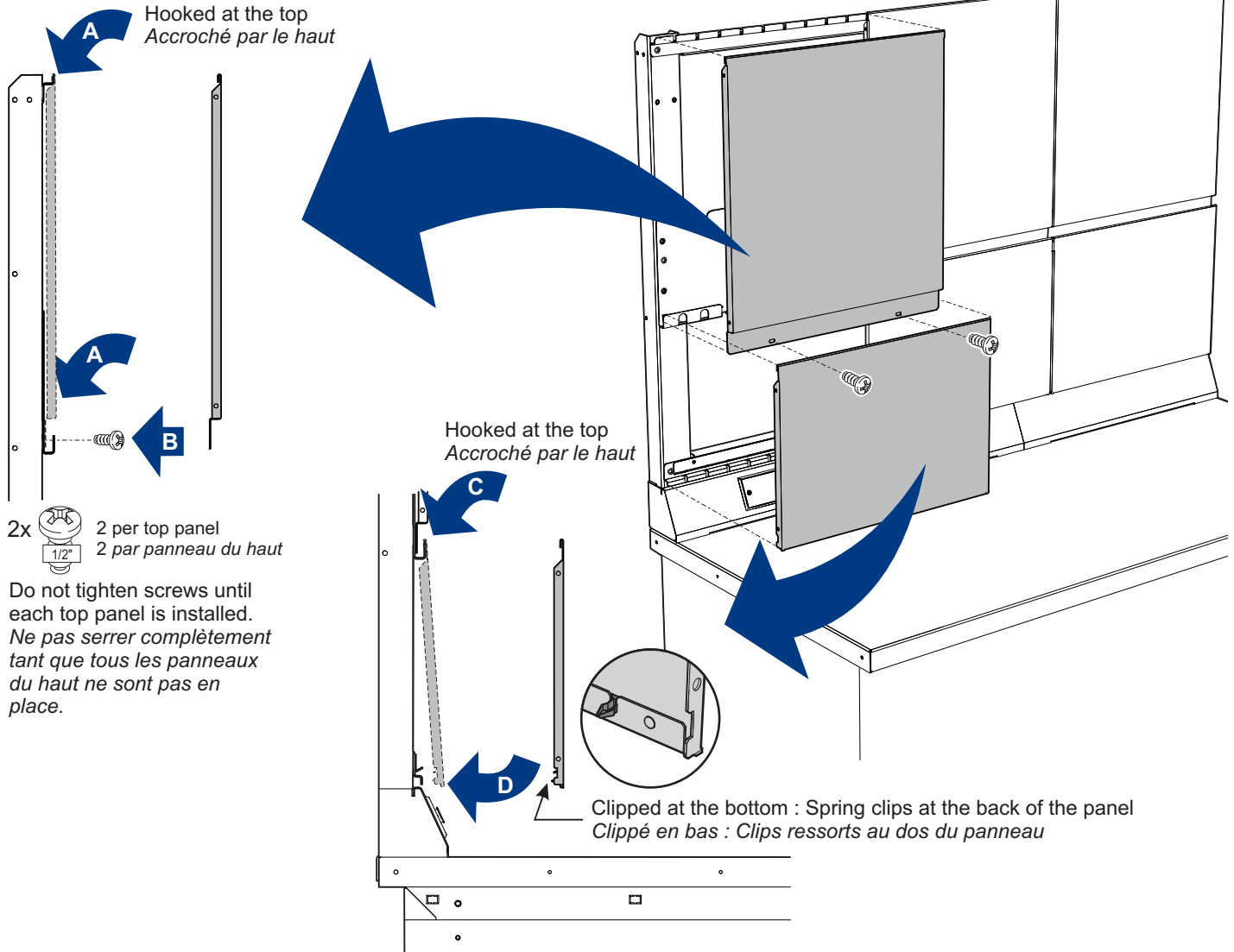

Without cabinet RD02/39 / 19" Uprights

Sans cabinet RD02/39 / Montants 19"

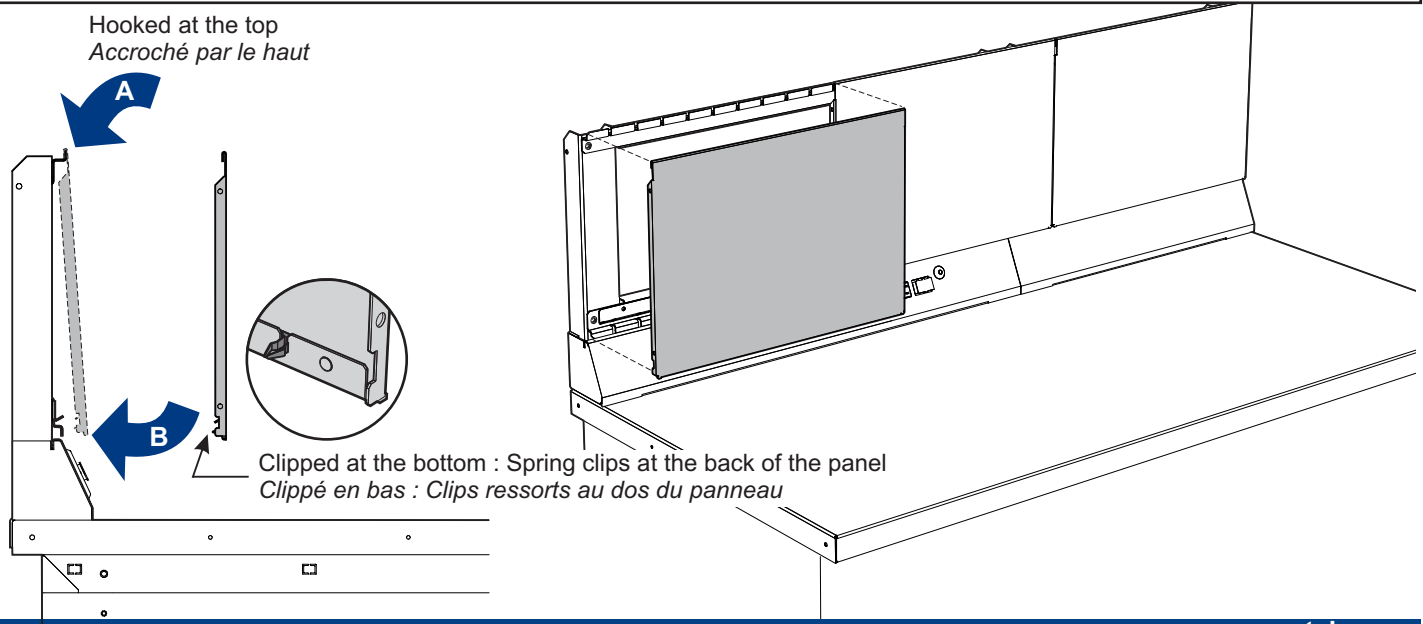

With cabinet RD02/39

Avec cabinet RD02/39

According to your needs, use knock out holes to manage your wiring .
Utiliser les différents trous à défoncer pour faire circuler les fils (selon vos besoins).

You can remove the back panel. Use plier to cut the tabs all around the panel.
Vous pouvez retirer l'arrière du cabinet. Utilisez des pinces coupantes pour couper les languettes autour du panneau.

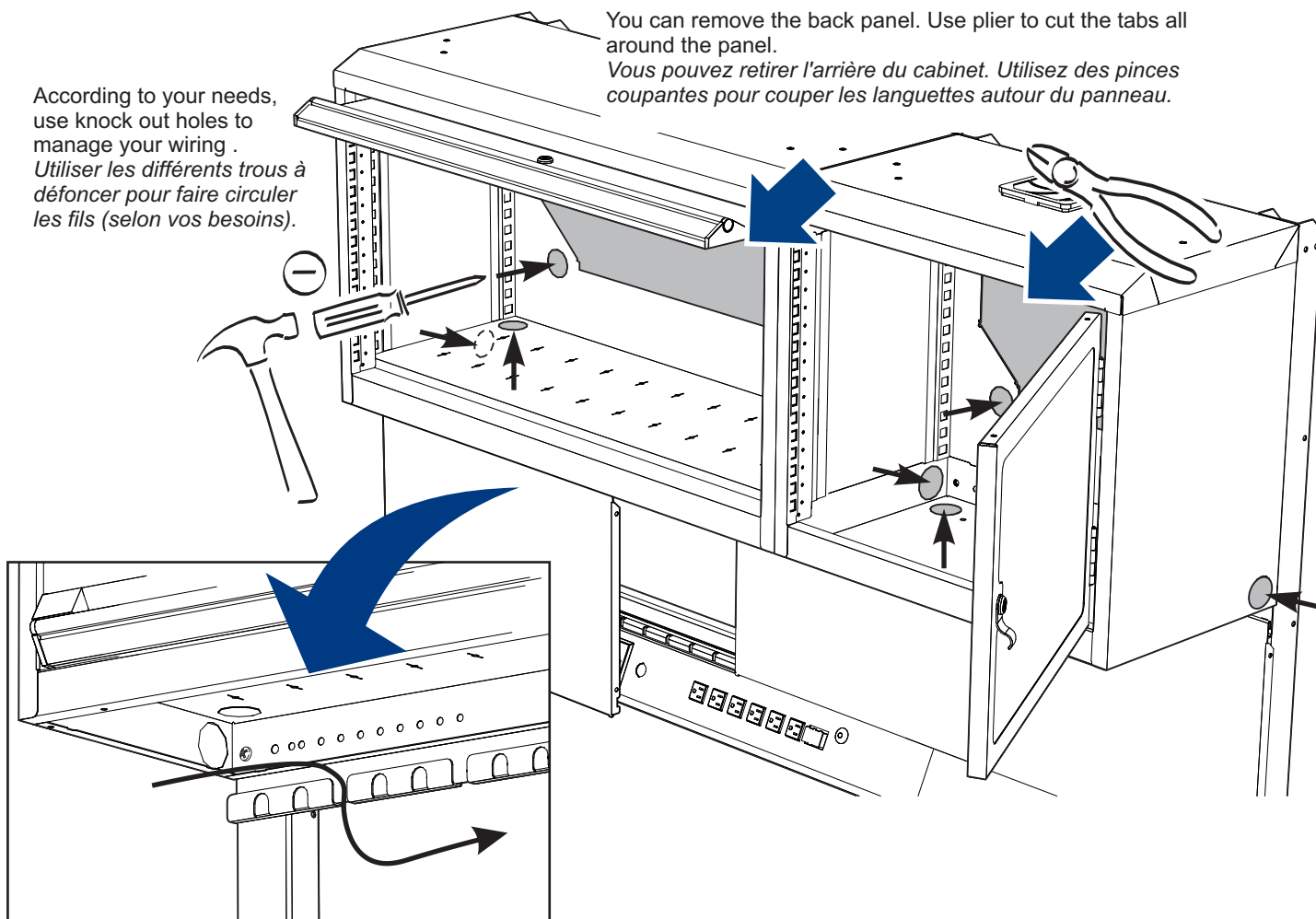

Without cabinet RD02/39

Sans cabinet RD02/39

