

FORK MOUNTED RUG-RAM - CRF-120

APPROX WEIGHT: 380.73 lbs.
DOES NOT INCLUDE WEIGHT OF POWER OR PACKAGING!!!

*** ANY ADDITIONS, DELETIONS, OR OMISSIONS MUST BE CORRECTED ON THIS DRAWING AS THIS DRAWING WILL BE CONSIDERED ALL INCLUSIVE ***

ALL GRAPHICS PROVIDED ARE FOR REFERENCE ONLY. IF CERTAIN DIMENSIONS ARE CRITICAL PLEASE VERIFY THOSE DIMENSIONS WITH YOUR SALESPERSON

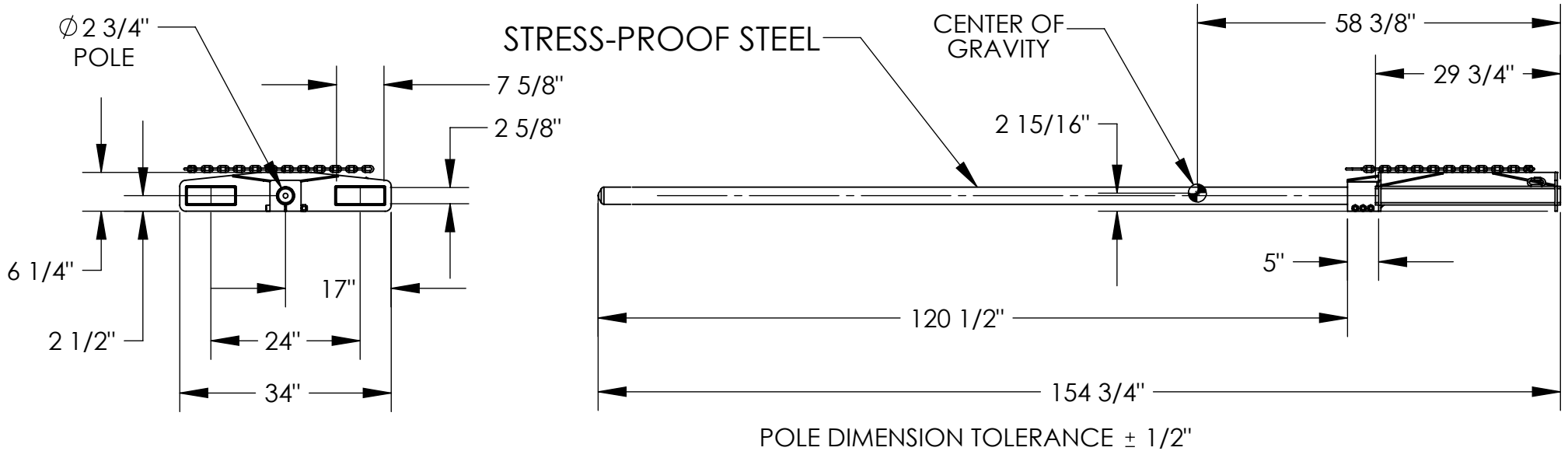

HORIZONTAL CENTER OF GRAVITY: $58 \frac{3}{8}$ "
VERTICAL CENTER OF GRAVITY: $2 \frac{15}{16}$ "
LOST LOAD: 380 LBS. (APPROX.)

STANDARD FEATURES

- MODEL NUMBER: CRF-120
- CAPACITY: 2,200 LBS. UNIFORM CAPACITY
- POLE LENGTH: $120 \frac{1}{2}$ "
- POLE DIAMETER: $2 \frac{3}{4}$ "
- FORK POCKETS ARE $7 \frac{5}{8}$ " W x $2 \frac{5}{8}$ " H
- USABLE ON 24" FORK CENTERS
- WITH SAFETY CHAIN TO SECURE TO THE UNIT TO THE MAST OF THE FORK TRUCK

SPECIAL FEATURES

NONE

NOTE: NEVER EXCEED LOAD CENTER RATING PER FORK TRUCK MANUFACTURER'S GUIDELINES. DO NOT USE THIS FORK TRUCK ATTACHMENT IF LOAD WILL EXCEED FORK TRUCK MANUFACTURER'S LOAD CENTER RATING.

APPROVAL	I, THE UNDERSIGNED, AGREE THAT THE PRODUCT AS REPRESENTED SATISFIES DESIGN AND DIMENSION REQUIREMENTS. I ALSO ACKNOWLEDGE MY DUTY TO CONFIRM PRODUCT AND INSTALLATION COMPLIANCE WITH ALL APPLICABLE FEDERAL, STATE AND LOCAL REGULATIONS AND STANDARDS.	
	ANY MODIFIED UNITS ARE NON-RETURNABLE	
	[] As drawn [] As marked	
	Signed: _____	Date: _____
Printed Name: _____		
LEAD TIME WILL START UPON RECEIPT OF SIGNED APPROVAL DRAWING		

FOR INTERNAL USE ONLY PROJECT SIGN OFF	
SALES	
ENG.	
FAB.	
POWER	

DISTRIBUTOR'S NAME:		P.O.#
VESTIL MANUFACTURING		X
DRAWN BY: BJW		W.O.#
DATE: 1/12/2008		X
REFERENCE: X	SCALE: 1:24	SALES: X
QUOTED LEAD TIME: X	QUOTE # X	FILE NAME:
		08-007-157