

MANUAL CYLINDER LIFTER, CYL-M-7

APPROX WEIGHT: 8.04 lbs.
DOES NOT INCLUDE WEIGHT OF POWER OR PACKAGING!!!

*** ANY ADDITIONS, DELETIONS, OR OMISSIONS MUST BE CORRECTED ON THIS DRAWING AS THIS DRAWING WILL BE CONSIDERED ALL INCLUSIVE ***

ALL GRAPHICS PROVIDED ARE FOR REFERENCE ONLY. IF CERTAIN DIMENSIONS ARE CRITICAL PLEASE VERIFY THOSE DIMENSIONS WITH YOUR SALESPERSON

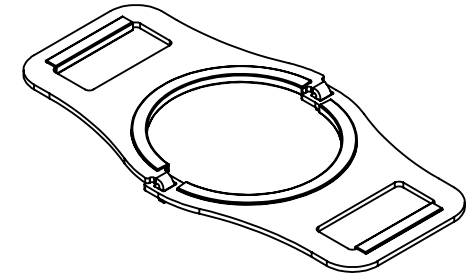
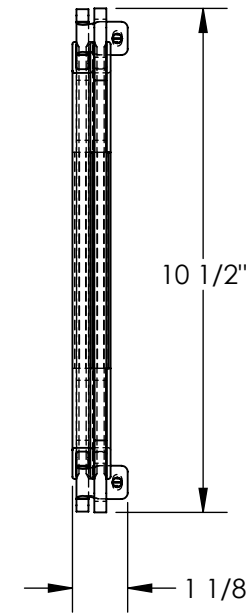
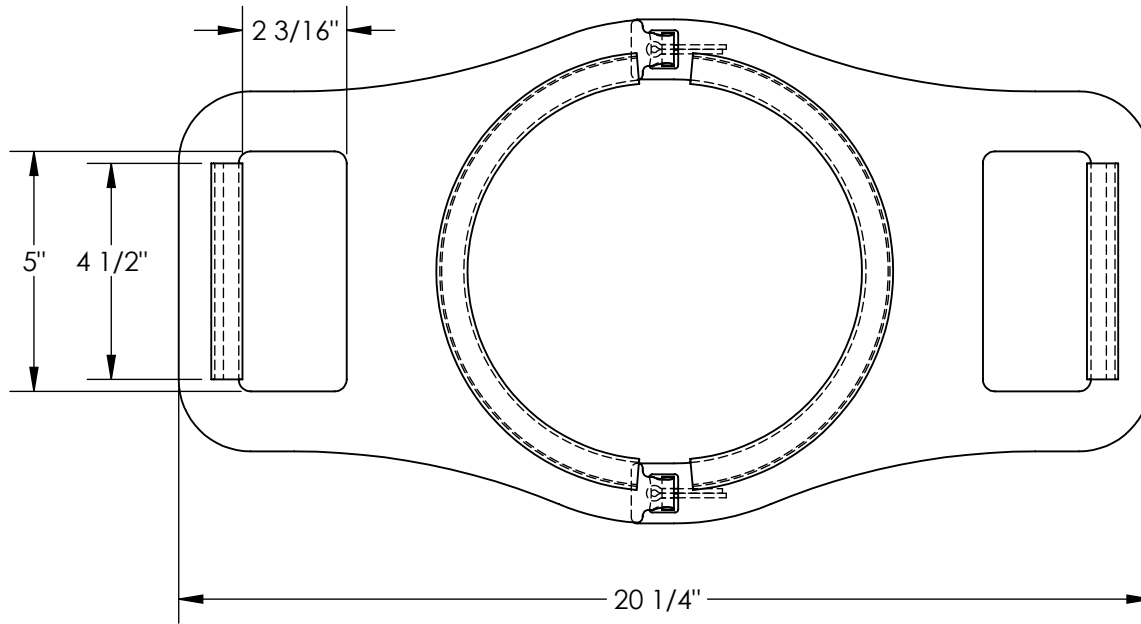

3D VIEW
SCALE 1:8

STANDARD FEATURES

- MODEL NUMBER IS CYL-M-7
- OVERALL WIDTH IS 20 1/4"
- OVERALL HEIGHT IS 1 1/8"
- OVERALL DEPTH IS 10 1/2"
- MAX. CAPACITY IS 200 LBS.
- MAX. CYLINDER SIZE IS Ø7"
- FOR USE WITH Ø7" CYLINDERS
- RUBBER GRIPPING ON HANDLES & CENTER
- STEEL CONSTRUCTION
- TOUGH BAKED IN POWDER COATED YELLOW FINISH

SPECIAL FEATURES

NONE

DIMENSION TOLERANCE ± 1/4"

A P P R O V A L	I, THE UNDERSIGNED, AGREE THAT THE PRODUCT AS REPRESENTED SATISFIES DESIGN AND DIMENSION REQUIREMENTS. I ALSO ACKNOWLEDGE MY DUTY TO CONFIRM PRODUCT AND INSTALLATION COMPLIANCE WITH ALL APPLICABLE FEDERAL, STATE AND LOCAL REGULATIONS AND STANDARDS.	
	ANY MODIFIED UNITS ARE NON-RETURNABLE	
	[] As drawn [] As marked	
	Signed: _____ Date: _____	
Printed Name: _____		
LEAD TIME WILL START UPON RECEIPT OF SIGNED APPROVAL DRAWING		

FOR INTERNAL USE ONLY PROJECT SIGN OFF	
SALES	
ENG.	
FAB.	
POWER	

DISTRIBUTOR'S NAME:		P.O.#
VESTIL MANUFACTURING		X
DRAWN BY: TJM		DATE: 10/10/13
REFERENCE: X		SCALE: 1:4
QUOTED LEAD TIME: X		QUOTE #
		X
		SALES: X
		FILE NAME:
		40-007-078