

# FORK EXTENSION- FE-4-84

APPROX WEIGHT: 129.89 lbs.  
DOES NOT INCLUDE WEIGHT OF POWER OR PACKAGING!!!

\*\*\* ANY ADDITIONS, DELETIONS, OR OMISSIONS MUST BE CORRECTED ON THIS DRAWING AS THIS DRAWING WILL BE CONSIDERED ALL INCLUSIVE \*\*\*

ALL GRAPHICS PROVIDED ARE FOR REFERENCE ONLY. IF CERTAIN DIMENSIONS ARE CRITICAL PLEASE VERIFY THOSE DIMENSIONS WITH YOUR SALESPERSON

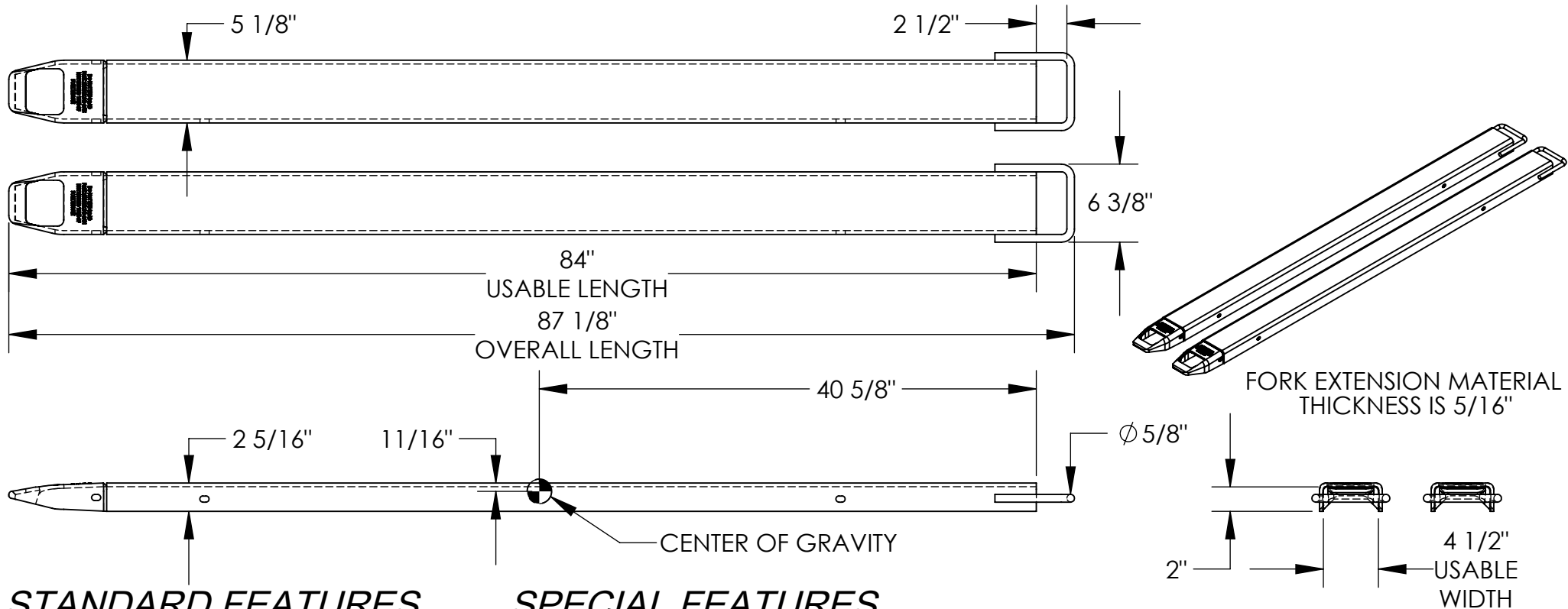

## STANDARD FEATURES

- MODEL NUMBER: FE-4-84
- FORK EXTENSION WIDTH: 5 1/8"
- OVERALL WIDTH W/ LOOP: 6 3/8"
- USABLE WIDTH: 4 1/2"
- OVERALL LENGTH: 87 1/8"
- USABLE LENGTH: 84"
- FITS 4" WIDE x 2" MAX. THICKNESS FORK
- SOLID STEEL CONSTRUCTION
- TOUGH BAKED IN POWDER COATED YELLOW FINISH

## SPECIAL FEATURES

NONE

DIMENSION TOLERANCE ± 1/4"

APPROX. WEIGHT / LOST LOAD = 129.89 LBS. EACH  
MINIMUM EFFECTIVE THICKNESS = LESS THAN 1"  
CAPACITY = 4,000 # PER PAIR, EVENLY DISTRIBUTED  
FORK EXTENSIONS DO NOT CHANGE THE LOAD  
CENTER OF EXISTING FORK TRUCK.  
NEVER EXCEED LOAD CENTER RATING PER FORK  
TRUCK MANUFACTURER'S GUIDELINES.  
DO NOT USE THESE FORK EXTENSIONS IF LOAD WILL  
EXCEED FORK TRUCK MANUFACTURER'S LOAD  
CENTER RATING.  
FORK EXTENSIONS MUST NOT EXCEED 150%  
ORIGINAL FORK LENGTH.

<b>APPROVAL</b>	I, THE UNDERSIGNED, AGREE THAT THE PRODUCT AS REPRESENTED SATISFIES DESIGN AND DIMENSION REQUIREMENTS. I ALSO ACKNOWLEDGE MY DUTY TO CONFIRM PRODUCT AND INSTALLATION COMPLIANCE WITH ALL APPLICABLE FEDERAL, STATE AND LOCAL REGULATIONS AND STANDARDS.	
	<b>ANY MODIFIED UNITS ARE NON-RETURNABLE</b>	
	[ ] As drawn      [ ] As marked	
	Signed: _____	Date: _____
	Printed Name: _____	
<b>LEAD TIME WILL START UPON RECEIPT OF SIGNED APPROVAL DRAWING</b>		

FOR INTERNAL USE ONLY PROJECT SIGN OFF	
SALES	
ENG.	
FAB.	
POWER	

DISTRIBUTOR'S NAME:		P.O.#
<b>VESTIL MANUFACTURING</b>		X
W.O.#		X
DRAWN BY:	Q.WESTFALL	DATE: 9/19/06
SALES:	X	X
REFERENCE:	X	SCALE: 1:12
QUOTED LEAD TIME:	X	QUOTE # X
		FILE NAME: 08-007-082