

FORK EXTENSION - FE-4-96

APPROX WEIGHT: 148.67 lbs.
 DOES NOT INCLUDE WEIGHT OF POWER OR PACKAGING!!!

*** ANY ADDITIONS, DELETIONS, OR OMISSIONS MUST BE CORRECTED ON THIS DRAWING AS THIS DRAWING WILL BE CONSIDERED ALL INCLUSIVE ***

ALL GRAPHICS PROVIDED ARE FOR REFERENCE ONLY. IF CERTAIN DIMENSIONS ARE CRITICAL PLEASE VERIFY THOSE DIMENSIONS WITH YOUR SALESPERSON

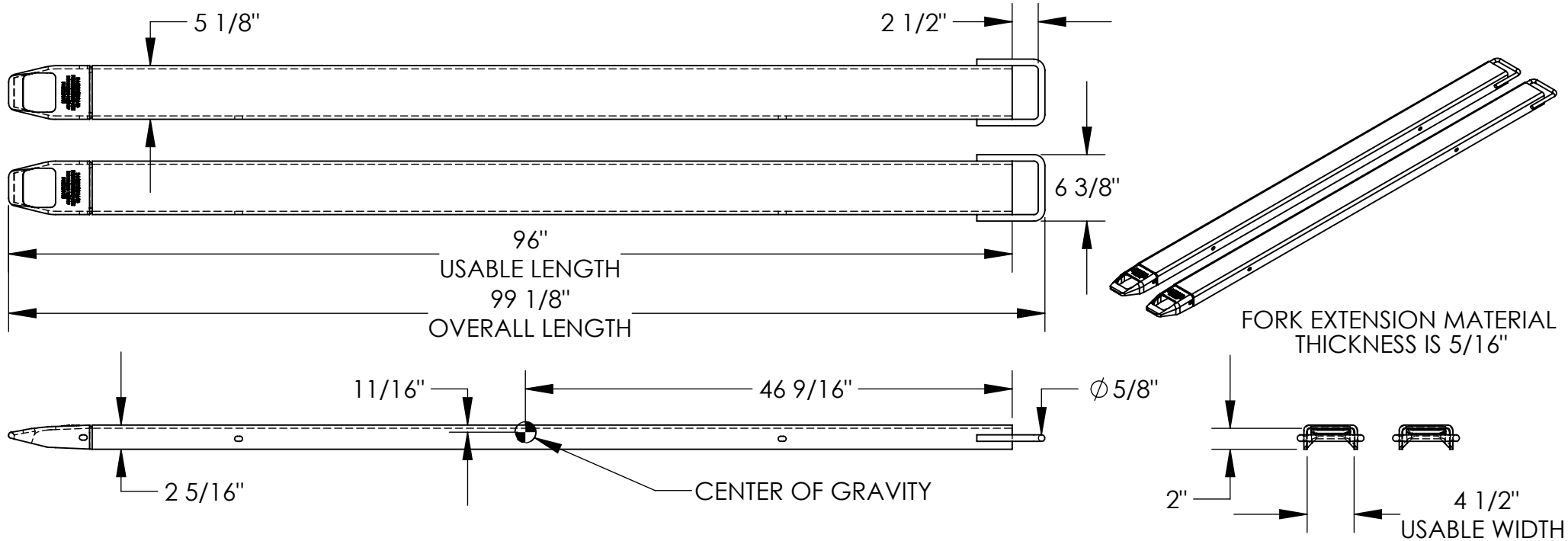

STANDARD FEATURES

MODEL NUMBER: FE-4-96
 FORK EXTENSION WIDTH: 5 1/8"
 OVERALL WIDTH W/ LOOP: 6 3/8"
 USABLE WIDTH: 4 1/2"
 OVERALL LENGTH: 99 1/8"
 USABLE LENGTH: 96"
 FITS 4" WIDE x 2" MAX. THICKNESS FORK
 SOLID STEEL CONSTRUCTION
 TOUGH BAKED IN POWDER COATED YELLOW FINISH
 APPROX. WEIGHT / LOST LOAD = 148.67 LBS. EACH
 MINIMUM EFFECTIVE THICKNESS = LESS THAN 1"
 CAPACITY = 4,000 # PER PAIR, EVENLY DISTRIBUTED
 FORK EXTENSIONS DO NOT CHANGE THE LOAD
 CENTER OF EXISTING FORK TRUCK.
 NEVER EXCEED LOAD CENTER RATING PER FORK
 TRUCK MANUFACTURER'S GUIDELINES.
 DO NOT USE THESE FORK EXTENSIONS IF LOAD WILL
 EXCEED FORK TRUCK MANUFACTURER'S LOAD
 CENTER RATING.
 FORK EXTENSIONS MUST NOT EXCEED 150%
 ORIGINAL FORK LENGTH.

SPECIAL FEATURES

NONE

DIMENSION TOLERANCE ± 1/4"

APPROVAL	I, THE UNDERSIGNED, AGREE THAT THE PRODUCT AS REPRESENTED SATISFIES DESIGN AND DIMENSION REQUIREMENTS. I ALSO ACKNOWLEDGE MY DUTY TO CONFIRM PRODUCT AND INSTALLATION COMPLIANCE WITH ALL APPLICABLE FEDERAL, STATE AND LOCAL REGULATIONS AND STANDARDS.	
	ANY MODIFIED UNITS ARE NON-RETURNABLE	
	[] As drawn [] As marked	
Signed: _____		Date: _____
Printed Name: _____		
LEAD TIME WILL START UPON RECEIPT OF SIGNED APPROVAL DRAWING		

FOR INTERNAL USE ONLY PROJECT SIGN OFF	
SALES	
ENG.	
FAB.	
POWER	

DISTRIBUTOR'S NAME:		P.O.#
VESTIL MANUFACTURING		X
W.O.#		X
DRAWN BY:	Q.WESTFALL	DATE: 9/19/06
SALES:	X	X
REFERENCE:	X	SCALE: 1:14
FILE NAME:		08-007-083
QUOTED LEAD TIME:	X	QUOTE #
		X