

PALLET DUMPER / RETAINER - PAL-D/R

APPROX WEIGHT: 280.69 lbs.
DOES NOT INCLUDE WEIGHT OF POWER OR PACKAGING!!!

ANY ADDITIONS, DELETIONS, OR OMISSIONS MUST BE CORRECTED ON THIS DRAWING AS THIS DRAWING WILL BE CONSIDERED ALL INCLUSIVE

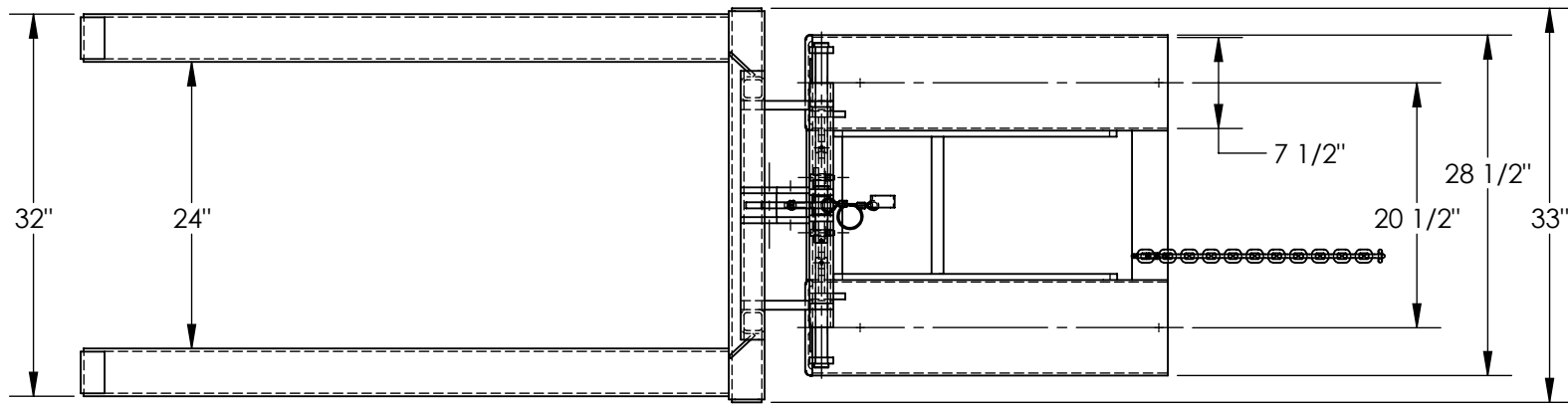

***ALL GRAPHICS PROVIDED ARE FOR REFERENCE ONLY. IF CERTAIN DIMENSIONS ARE CRITICAL PLEASE VERIFY THOSE DIMENSIONS WITH YOUR SALESPERSON

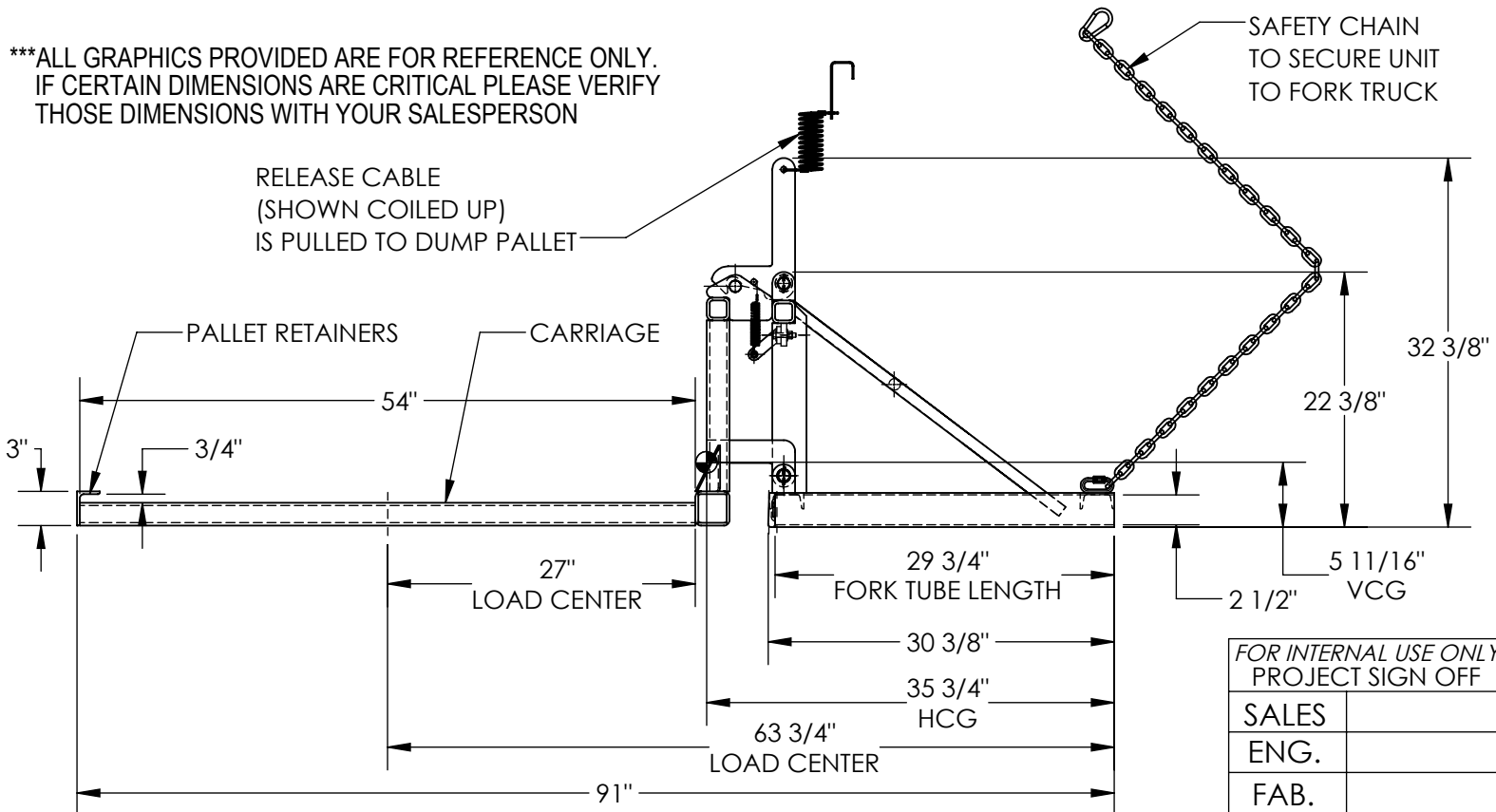

FOR INTERNAL USE ONLY PROJECT SIGN OFF	
SALES	
ENG.	
FAB.	
POWER	

NEVER EXCEED LOAD CENTER RATING PER FORK TRUCK MANUFACTURER'S GUIDELINES. DO NOT USE THIS FORK ATTACHMENT IF LOAD WILL EXCEED FORK TRUCK MANUFACTURER'S LOAD CENTER RATING.

DIMENSION TOLERANCE ± 1/4"

STANDARD FEATURES

- MODEL NUMBER: PAL-D/R
- CAPACITY: 2,000 LBS.
- OVERALL LENGTH: 91"
- OVERALL WIDTH: 33"
- OVERALL HEIGHT: 32 3/8"
- USABLE FORK POCKETS: 7 1/2"W x 2 1/2"H
- FORK POCKET CENTERS: 20 1/2" APART
- PALLET DUMPED BY PULLING RELEASE CABLE
- UNIT IS PAINTED: FRAME IS BLUE
- CARRIAGE AND LATCH HANDLE ARE YELLOW

SPECIAL FEATURES

NONE

HCG: 35 3/4"
VCG: 5 11/16"
LOST LOAD: 281 LBS.
LOAD CENTER: 63 3/4"
(EFFECTIVE THICKNESS EQUALS THE TOTAL FORK LENGTH MINUS THE FORK TUBE LENGTH)

APPROVAL

I, THE UNDERSIGNED, AGREE THAT THE PRODUCT AS REPRESENTED SATISFIES DESIGN AND DIMENSION REQUIREMENTS. I ALSO ACKNOWLEDGE MY DUTY TO CONFIRM PRODUCT AND INSTALLATION COMPLIANCE WITH ALL APPLICABLE FEDERAL, STATE AND LOCAL REGULATIONS AND STANDARDS.

ANY MODIFIED UNITS ARE NON-RETURNABLE

[] As drawn [] As marked

Signed: _____ Date: _____

Printed Name: _____

LEAD TIME WILL START UPON RECEIPT OF SIGNED APPROVAL DRAWING

DISTRIBUTOR'S NAME:		P.O.#
VESTIL MANUFACTURING		X
DRAWN BY: BJB		W.O.#
DATE: 6/30/14		X
REFERENCE: X	SCALE: 1:16	SALES: X
QUOTED LEAD TIME: X	QUOTE # X	FILE NAME:
		15-007-054