

# RATCHET TRAILER STABILIZING JACK - SP-TOP-R

APPROX WEIGHT: 104.65 lbs.  
DOES NOT INCLUDE WEIGHT OF POWER OR PACKAGING!!!

\*\*\* ANY ADDITIONS, DELETIONS, OR OMISSIONS MUST BE CORRECTED ON THIS DRAWING AS THIS DRAWING WILL BE CONSIDERED ALL INCLUSIVE \*\*\*

ALL GRAPHICS PROVIDED ARE FOR REFERENCE ONLY. IF CERTAIN DIMENSIONS ARE CRITICAL PLEASE VERIFY THOSE DIMENSIONS WITH YOUR SALESPERSON

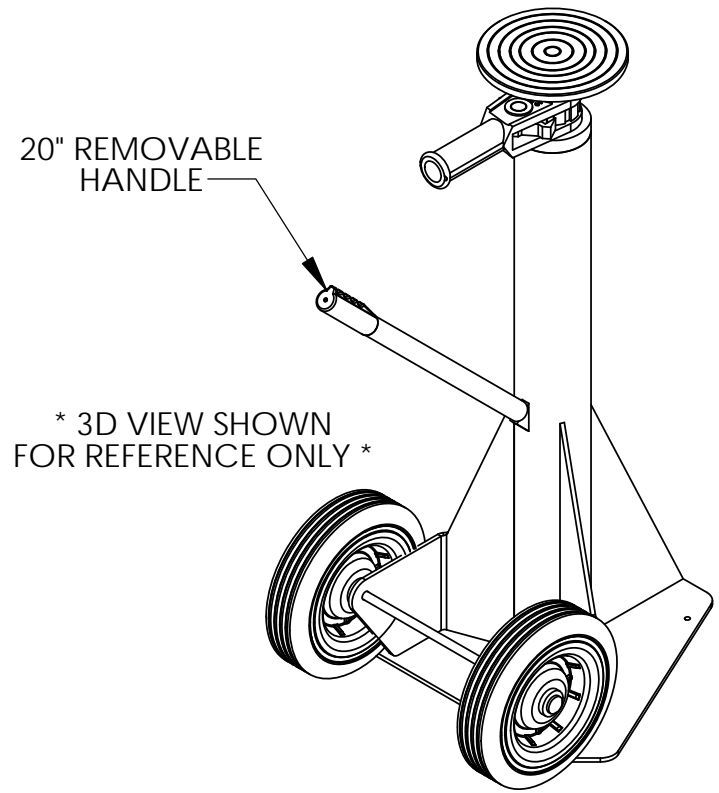
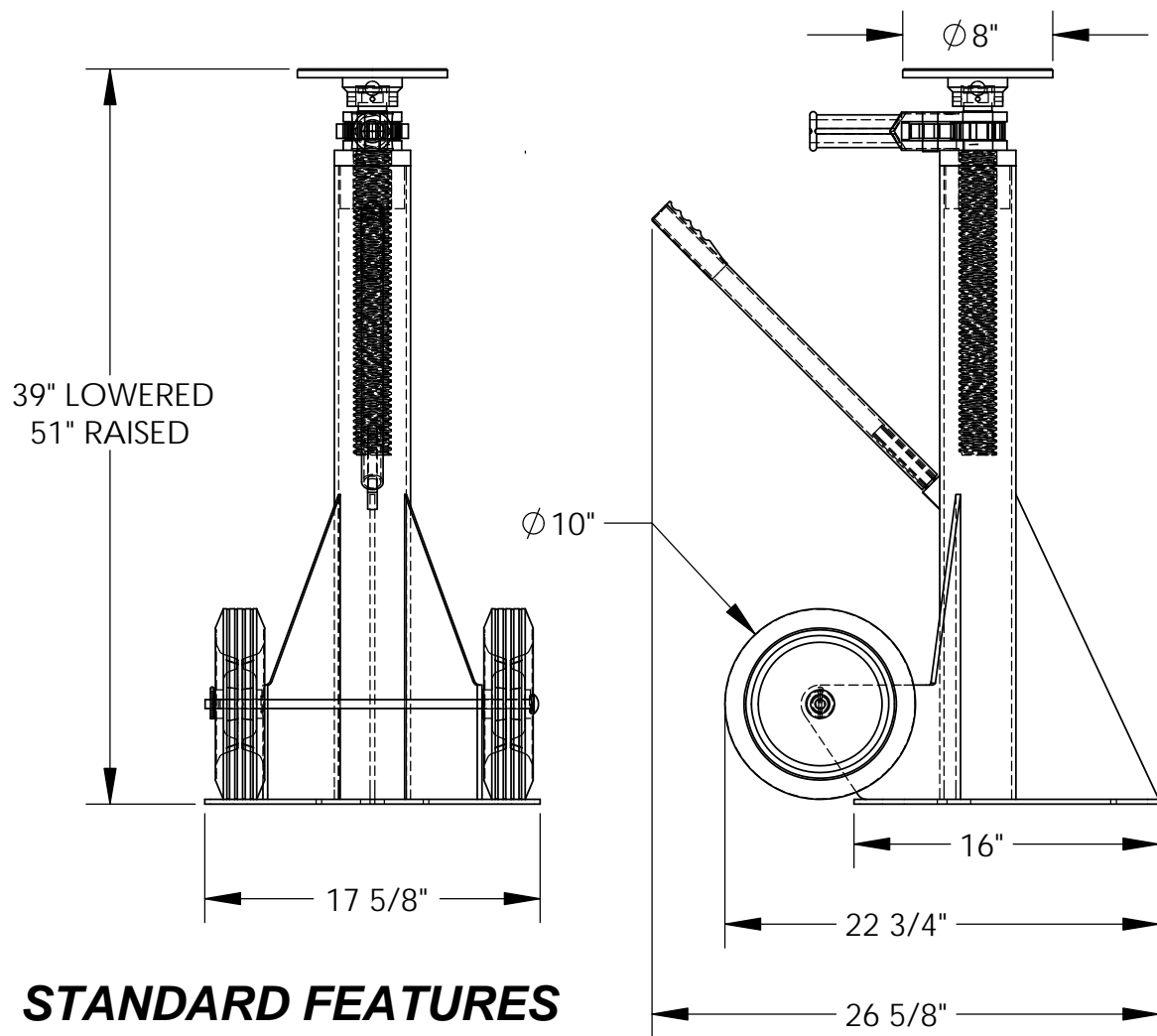

\* 3D VIEW SHOWN FOR REFERENCE ONLY \*

DIMENSION TOLERANCE ± 1/4"

## STANDARD FEATURES

- MODEL NUMBER: SP-TOP-R
- OVERALL WIDTH: 17 5/8"
- OVERALL LENGTH: 26 5/8"
- SERVICE RANGE: 39" TO 51"
- STATIC CAPACITY: 100,000 LBS.
- LIFTING CAPACITY: 40,000 LBS.
- TOP CAP: 8" DIAMETER
- WHEEL SIZE IS Ø10"
- HANDLE LENGTH IS 20"

## SPECIAL FEATURES

NONE

**APPROVAL**

I, THE UNDERSIGNED, AGREE THAT THE PRODUCT AS REPRESENTED SATISFIES DESIGN AND DIMENSION REQUIREMENTS. I ALSO ACKNOWLEDGE MY DUTY TO CONFIRM PRODUCT AND INSTALLATION COMPLIANCE WITH ALL APPLICABLE FEDERAL, STATE AND LOCAL REGULATIONS AND STANDARDS.

**ANY MODIFIED UNITS ARE NON-RETURNABLE**

[ ] As drawn [ ] As marked

Signed: \_\_\_\_\_ Date: \_\_\_\_\_

Printed Name: \_\_\_\_\_

LEAD TIME WILL START UPON RECEIPT OF SIGNED APPROVAL DRAWING

FOR INTERNAL USE ONLY PROJECT SIGN OFF	
SALES	
ENG.	
FAB.	
POWER	

DISTRIBUTOR'S NAME:		P.O.#
VESTIL MANUFACTURING		X
DRAWN BY:	DATE:	W.O.#
B.NOTHNAGEL	05/14/2015	X
REFERENCE:	SCALE:	SALES:
X	1:10	X
QUOTED LEAD TIME:	QUOTE #	FILE NAME:
X	X	13-007-028

MAXIMUM WORKING CAPACITY AT GRADE (%)								
0.00%	0.50%	1.00%	1.50%	2.00%	2.50%	3.00%	3.50%	4.00%
100,000	80,000	66,000	55,000	46,000	41,000	37,000	33,000	29,000