

MASTER CATALOG

WWW.WESCOMFG.COM

WWW.LEXCOENG.COM

WESCO[®]
Industrial Products, Inc.

LEXCO
Custom Lift Tables



DRUM EQUIPMENT

HAND TRUCKS

LIFT EQUIPMENT

PLATFORM TRUCKS & CARTS

STAINLESS STEEL

AN IWS COMPANY

IWS INTEGRATED WAREHOUSE SOLUTIONS™





Drum Handling Equipment

Drum Trucks - Steel, Aluminum, Stainless , 4-Wheel Drum Cart, KD Drum Truck	3-6
Drum Dollies - Steel, Aluminum, Stainless Steel & Polypropylene, Pail Truck & Pail Tipper.....	7-8
Drum Trucks, Carriers, Dispensers	9
Drum Racks, Cradles.....	10
Drum Lifters, Steel & Stainless Steel	11
Drum Sling and Dispensers	12
Gator Grip Drum Grab, Triple Truck Drum Attachment	13
Ergonomic Drum Handlers, Steel & Stainless Steel , Manual, Scale, Powered, High Reach.....	14-15
Fork Drum Grabs, Fork Truck Drum Dispensers, Poly Drum Lifters	16
FM Approved Drum Faucets, Plastic Drum Faucets.....	17
FM Approved Drum Vent, Wires, Gauges, Funnel, Pop-Up Gauges	18
Drum Deheaders & Wrenches.....	19
Drum Pumps & Drip Pans, Stainless Steel Rotary Pump	20

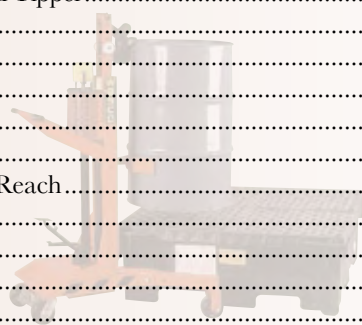

Hand Trucks

Industrial Duty Steel Hand Trucks, Stainless Steel Hand Truck	21-22
2-in-1, Convertible Steel Hand Trucks, Curb Ramp	23
Standard Duty Steel Hand Trucks.....	24
Touch-N-Tilt, Drum Hand Trucks, Stainless Steel Drum Truck , 4-Wheel Drum Cart	25
Heavy Duty Hand Trucks	26
Heavy Duty Warehouse and Economy Trucks	27
Cylinder Carts and Trucks	28-29
Aluminum Cobra-Lite Hand Trucks, Options, Components, Handles	30-33
Aluminum Cobra Convertible, Spartan Economy Convertible, Powered CobraPro.....	34-35
Aluminum Mini Cobra, 3 Position Cobra, Spartan III, Options	36
Power LiftKar, StairKing Stairclimbing Trucks, Options.....	37-40
Vending & Appliance Trucks, Steel & Aluminum, Standard & Heavy Duty	41-43



Lift Equipment

Pallet Trucks Manual & Powered, Narrow Aisle, Stainless , Quick Lift, Walkie Stacker	44-53
Pallet Jack Stop, Pallet Truck Chock, Backrest Guards	54
Steel Pedalifts: Winch & Hydraulic Lifters, Stainless Pedalifts	55-56
Cylinder & Universal Lifts, Hydraulic & Winch Lite Lifts	57
Triple Truck, Aluminum Pedalifts	58
Hand Winch Lifts	59
Platform Stackers, 1,000 lb Winch Stackers	60
Fork Stackers	61
Manual & Electric Value Lifts, Office Lifts, Premium Light Duty Winch Lift	62
2,200 lb Power Drive & Counter-Balance Stackers	63
1,000, 1,500, 2,000 lb Powered Stackers-Platform, Fork, Adjustable, Telescoping, Dual Platform Stacker.....	64-67
Wesco®, Lexco® Hydraulic Lift Tables, Lexco Die Handlers, Roller & Ball Transfer Tops	68-74
Scissors Lift Tables, Die Lift Tables, Double Scissors Table, Long Deck Tables.....	75-76
Powered Lift Scissors Tables	77
Pallet Levelers, Spring & Pneumatic	78
Rais-N-Rol™ Machinery Movers, Furniture Movers & Trolleys.....	79-80



Platform Trucks, Carts & Dollies

Platform Trucks - Aluminum, Steel Grid, Steel, Panel Cart, Power Drive, Wood Dollies.....	81-85
U-Boats; Aluminum, Steel, Wood, Shelf Option	86
Folding-Handle Platform Trucks; Steel, Stainless , Aluminum.....	87-88
Stainless Steel Carts	89
Steel & Plastic Service Carts, Plastic Platform Trucks	90-91
Wire Basket & Table Top Office Carts, File Cabinet Truck, Desk Mover.....	92
Lightweight Folding Trucks	93
Tilt Carts.....	94
Polyethylene Tub Carts	95

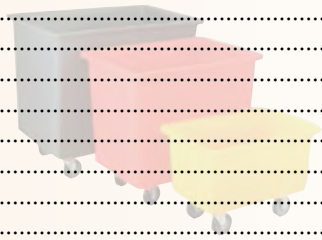

Dock and Shipping Equipment, Wire Shelving and Wheels

Strapping Truck & Tools, UL Approved Dock Lights.....	96
Strip Doors.....	97
NSF Approved Wire Shelving & Accessories	98-99
Trailer Stabilizing Jacks, Cargo Bars	100
Fork Extensions, Maintenance Platform, Battery Transfer Cart, Trolleys.....	101
Wheels.....	102-103



A 5 Year Guarantee Against Weld Failure. A Wesco Quality Exclusive.

DRUM TRUCK FEATURES:

■ Heavy duty, double-welded joints.

■ 1" structural steel frame.

■ Kickstands to store upright.



5BT



5BTW

5BT & 5BTW Economy Series

- Kickstand.
- With wheels resting on floor, 22" to center of lowered chime hook.
- **Steel drums only.**
- Handles 55 & 85 gallon steel drums.

OVERALL DIMENSIONS

w: 24.5"
h: 62"
d: 17"



10BT



10BTW

10BT & 10BTW Standard Series

- Machined steel load wheels behind nose prongs help ease the lifting of the drum.
- With wheels resting on floor, 22" to center of lowered chime hook.
- **Steel drums only.**
- Handles 55 & 85 gallon steel drums.

OVERALL DIMENSIONS

w: 24.5"
h: 61"
d: 14.5"



15BT



15BT & 15BTW Deluxe Series

- Four wheel design enables user to quickly and easily load and unload drums from pallet.
- With two wheels resting on floor, 20.5" to center of lowered chime hook.
- Replaceable hard faced double-beveled nose prongs, Part # 240060.
- **Steel drums only.**
- Handles 30, 55 & 85 gallon steel drums.

OVERALL DIMENSIONS

w: 24"
h: 58"
d: 21"



6" x 2" Special swivel caster design for tight turning radius



15BTC

15BTC Ergonomic Drum Truck

- Ergonomic swivel caster design reduces operator muscle strain and fatigue.
- With two wheels resting on floor, 20.5" to center of lowered chime hook.
- Replaceable hard faced double-beveled nose prongs, Part # 240060.
- **Steel drums only.**
- Handles 30, 55 & 85 gallon steel drums.

OVERALL DIMENSIONS

w: 24"
h: 58"
d: 21"



20BT



20BT & 20BTW-Deluxe Series

- Floating axle reduces effort required to break over and balance load.
- Chime hook can be stored at the top of the frame for easy use.
- Replaceable hard faced double-beveled nose prongs, Part # 240060.
- **Steel drums only.**
- Handles 30, 55 & 85 gallon steel drums.

OVERALL DIMENSIONS

w: 23.5"
h: 60"
d: 17"



30BT

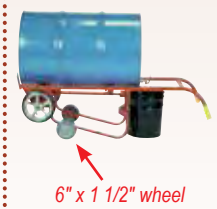

6" x 1 1/2" wheel

30BT & 30BTW-Standard Series

- Multi-functional drum truck allows you to move drums on four wheels and acts as a drum cradle for storage or dispensing.
- 16.5" drain height.
- With two wheels resting on floor, 28" to bottom of lowered chime hook.
- **Steel drums only.**
- Handles 30, 55 & 85 gallon steel drums.

OVERALL DIMENSIONS

w: 24"
h: 56"
d: 20.5"

Part #	240009	240010	240013	240014	240001	240002	240121	240003	240004	240005	240006
Model #	5BT	5BTW	10BT	10BTW	15BT	15BTW	15BTC	20BT	20BTW	30BT	30BTW
Capacity	1,000 lbs	1,000 lbs	1,000 lbs	1,000 lbs	1,000 lbs	1,000 lbs	1,000 lbs	1,000 lbs	1,000 lbs	1,000 lbs	1,000 lbs
10" Wheel	Moldon Rubber	Polyolefin	Moldon Rubber	Polyolefin	Moldon Rubber	Polyolefin	Moldon Rubber	Moldon Rubber	Polyolefin	Moldon Rubber	Polyolefin
6" Wheel	N/A	N/A	N/A	N/A	Moldon Rubber	Polyolefin	Moldon Rubber	N/A	N/A	Moldon Rubber	Polyolefin
Weight	68 lbs	53 lbs	64 lbs	50 lbs	79 lbs	61 lbs	79 lbs	74 lbs	59 lbs	82 lbs	66 lbs



A 5 Year Guarantee Against Weld Failure. A Wesco Quality Exclusive.

DRUM TRUCK FEATURES:

- Heavy duty, double-welded joints. ■ 1" structural steel frame.
- Self standing or with kick stand for upright storage.



40 BT



45BT



50 BT

Rear wheels on 50BT –
Aluminum Ctr. Moldon Rubber
Rear wheels on 50BTW – Polyolefin

40BT & 40BTW Series

- Handles all poly and fiber drums except overpacks (use 45BT for overpacks).
- Replaceable feet - Part# 240115 and replaceable belt - Part# 150303.
- Floating axle reduces effort required to break over and balance load.
- With wheels resting on floor, 28" to bottom of belt.
- Handles 30, 55 & 85 gal. drums.
- **Steel, poly & fiber drums.**

OVERALL DIMENSIONS

w: 23.75"
h: 59.75"
d: 24"

45BT & 45BTW Series

- Recommended primarily for handling of overpacks.
- Wide "feet" eliminate the risk of drums being punctured by nose prongs.
- Replaceable feet - Part # 240115 and replaceable belt - Part # 150304.
- Floating axle reduces effort required to break over and balance load.
- With wheels resting on floor, 28" to center of belt.
- Handles 30, 55 & 85 gal. drums.
- **Steel, poly & fiber drums.**

OVERALL DIMENSIONS

w: 24"
h: 59.75"
d: 24"

50BT & 50BTW Series

- Acts as a Poly Drum Truck or Drain Stand.
- Wide "feet" and belt eliminate the risk of drums being punctured by nose prongs and chime hooks.
- With two wheels resting on floor, 32" to center of belt.
- Handles all poly drums (except overpacks).
- Handles 30, 55 & 85 gal. drums.
- **Steel, poly & fiber drums.**

OVERALL DIMENSIONS

w: 24"
h: 57.5"
d: 25"

Part #	240081	240076	240082	240077	240083	240078
Model #	40BT	40BTW	45BT	45BTW	50BT	50BTW
Capacity	1,000 lbs	1,000 lbs	1,000 lbs	1,000 lbs	1,000 lbs	1,000 lbs
10" Wheel	Moldon Rubber	Polyolefin	Moldon Rubber	Polyolefin	Moldon Rubber	Polyolefin
6" Wheel	N/A	N/A	N/A	N/A	Moldon Rubber	Polyolefin
Weight	82 lbs	67 lbs	82 lbs	67 lbs	86 lbs	65 lbs

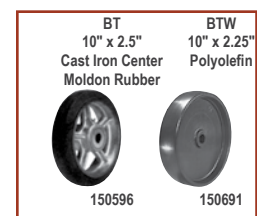



US PATENT NO. 9,302,688



#240016



#240019 WITH (#240211) OPTIONAL 3RD WHEEL 304 STAINLESS STEEL

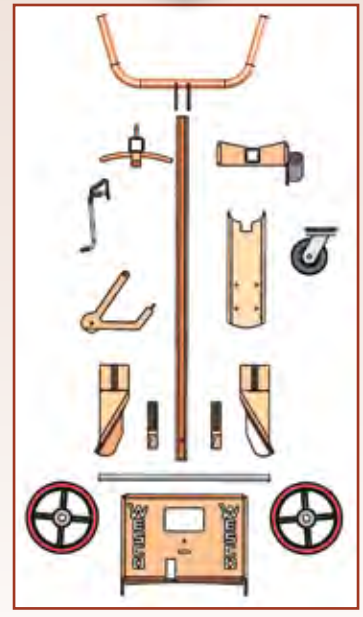

#240017



#240017 WITH (#240210) OPTIONAL 3RD WHEEL



Knock Down (KD) Drum Trucks

- UPSable - KD and boxed.
- Six models: (4) Steel and (2) **304 Stainless** Construction.
- Handles 30, 55 and 85 gallon drums.
- Models to handle steel and poly drums.
- Requires minimal assembly.
- All parts removable and interchangeable.
- Each of the six models include handle, frame, base, kickstand, axle, toe or feet, wheels, chime hook or belt and hardware.
- Foot operated break-over assist bar provides extra leverage to tilt and balance load and allows truck to rest in tilt-back position.
- **Stainless** models okay for wash down.

- **Optional 3rd Wheel:**
- Ergonomic design, better maneuverability.
 - Better load support.
 - Helps reduce breakerover effort.
 - 5" x 2" swivel caster.
 - Two Models: #240210 for steel trucks, 13 lbs. #240211 for **304 stainless** trucks, 14 lbs.

Part #	240016	240017	240052	240053	240019	240020
Model #	KD-STL-STL-PU	KD-STL-POLY-PU	KD-STL-STL-PO	KD-STL-POLY-PO	KD-SS-STL-PO	KD-SS-POLY-PO
Capacity	1,000 lbs	1,000 lbs	1,000 lbs	1,000 lbs	1,000 lbs	1,000 lbs
Wheel	10" x 2.5" Polyurethane	10" x 2.5" Polyurethane	10" Polyolefin	10" Polyolefin	10" Polyolefin	10" Polyolefin
Drum Type Handled	Steel	Poly	Steel	Poly	Steel	Poly
Toe/Foot (replaceable)	Milled Toe #240060	Formed Foot #240115	Milled Toe #240060	Formed Foot #240115	Stainless Milled Toe #051904	Stainless Foot #050362
Construction	Steel	Steel	Steel	Steel	304 Stainless	304 Stainless
Chime Hook	#240214 - steel	N/A	#240214 - steel	N/A	#050197- stainless	N/A
Belt	N/A	#240212 - steel ratchet assembly	N/A	#240212 - steel ratchet assembly	N/A	#240213 - stainless buckle
Weight	70 lbs	78 lbs	63 lbs	71 lbs	66 lbs	75 lbs

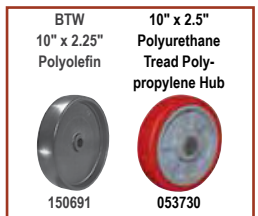

DRUM HANDLING EQUIPMENT



240120



210353

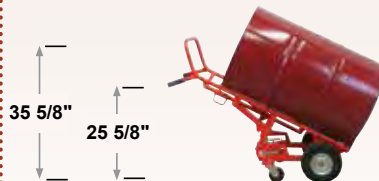

4-Wheel Drum Cart

- Two position, 4-wheel transport design to handle drums and standard loads.
- **Position I:** Easily handles and maneuvers standard loads as a 4-wheel transport.
- **Position II:** With the chime hook engaged and a press of the foot pedal, the frame tilts a 30 or 55 gallon steel drum to a balanced position to maintain 4-wheel contact even with half empty bottom heavy drums.
- Two 3.5" x 1.5" polyolefin swivel casters for easy maneuverability in narrow spaces.
- Chime hook to engage 30 & 55 gallon steel drums.
- 7.8" D x 14" W beveled edge noseplate.
- Curved frame holds 5-gallon pails and kegs.

OVERALL DIMENSIONS

w:	19.25"	19.25"
h:	48"	48.5"
d:	26.25"	25"



156DH-PP8-SS
304 STAINLESS STEEL



156DH Drum/Hand Truck

- Utility of a hand truck and drum truck.
- Chime hook works with 55 and 30-gallon steel drums.
- Curved frame holds 5-gallon pails and kegs.
- With noseplate resting flat on floor, 15.5" to center of lowered chime hook.
- Noseplate 7.8" D x 14" W.
- 304 stainless steel model #210352.
- Stainless model has 8" polyurethane, non-marking wheels with stainless precision ball bearings.

OVERALL DIMENSIONS

w:	20.5"	20.5"	20.5"	20.5"
h:	48"	48"	48"	48"
d:	18.5"	17.5"	18.5"	18.5"

Stainless

Manual Aluminum Drum Trucks

- Spring loaded chime hook automatically engages drum.
- Two chime hooks available:
 - SCH: standard hook for closed head steel, fiber and poly drums (SC). (Not for use on drums with locking ring or 85 gallon size.)
 - LCH: special order hook for steel, fiber and poly drums with locking rings. Can be used on 85 gallon drums.
- Two wheel choices:
 - 10" Moldon Rubber on Aluminum Hub - #055684.
 - 12" Pneumatic Steel Hub - #108484.
- Disc wheel brake activated by hand lever:
 - B: with brake.
 - NB: no brake.
 - Example: ABT-10-SC-NB (no brake).
- Steel, poly and fiber drums.
- 30 and 55 gallon drums.

OVERALL DIMENSIONS

w:	25.875"
h:	60"
d:	18.5"

Part #	240124	240132	240120	240134	210353	210354	210340	210349	210266	210352
Model #	ABT-10-SC-B	ABT-10-SC-NB	ABT-12-SC-B	ABT-12-SC-NB	4WDC-ZC	4WDC-HBC	156DH-Z	156DH-HB	156DH-P	156DH-PP8-SS
Capacity	1,000 lbs	1,000 lbs	1,000 lbs	700 lbs	800 lbs	900 lbs	700 lbs	800 lbs	700 lbs	600 lbs
Brake	Yes	No	Yes	No	N/A	N/A	N/A	N/A	N/A	N/A
Wheels	10" Moldon Rubber Rear 6" Moldon	10" Moldon Rubber Rear 6" Moldon	12" Pneumatic Rear 6" Moldon	12" Pneumatic Rear 6" Moldon	10"/ Z	8"/ HB	Z	HB	P	8" Polyurethane
Weight	60 lbs	60 lbs	60 lbs	60 lbs	66 lbs	66 lbs	39 lbs	42.5 lbs	39 lbs	33.5 lbs

HB Cast Iron 8" x 2" Moldon Rubber	Z Steel Offset 10" x 2.75" Semi-Pneumatic	P Steel Offset 10" x 3.5" Pneumatic	P-12 12" x 4" Pneumatic	10" x 2.5" Moldon Rubber Aluminum Hub	PP8 8" x 2" Polyurethane Tread Polypropylene Hub 3/4" Ball Bearings
150120	150589	050602	108484	055684	053733

Stainless Steel Drum Dollies

- **Wesco's Stability Advantage.** By design, Wesco casters are mounted past the dolly and drum rim. Our casters are mounted further apart than standard designs with casters completely underneath the drum and closer together. The further the casters are apart the greater the stability.
- Welded **304 stainless steel** dolly construction with reinforced outriggers.
- **304 stainless steel** dollies are ideal for clean room, pharmaceutical, food and wash down applications.
- Models available for 30, 55, and 85 gallon drums.



SS5-PPSS
All stainless rigs with 3" polypropylene wheels

- Three caster set options:
 HRZ: zinc plated swivel rig with 3" hard rubber wheel & zinc plated hardware
 *HRSS: **304 stainless steel** swivel rig with 3" hard rubber wheel & stainless hardware
 *PPSS: **304 stainless steel** swivel rig with 3" white polypropylene wheel & stainless hardware.
 *Suitable for wash down applications.

ASSEMBLED OVERALL DIMENSIONS SS3

w: 24"
h: 6"
d: 24"

ASSEMBLED OVERALL DIMENSIONS SS5

w: 28.5"
h: 6"
d: 28.5"

ASSEMBLED OVERALL DIMENSIONS SS8

w: 31.5"
h: 6"
d: 31.5"

Part #	240192	240193	240194	240195	240196	240197	240198	240199	240200
Model #	SS3-HRZ	SS3-HRSS	SS3-PPSS	SS5-HRZ	SS5-HRSS	SS5-PPSS	SS8-HRZ	SS8-HRSS	SS8-PPSS
Capacity	900 lbs	900 lbs	1,000 lbs	900 lbs	900 lbs	1,000 lbs	900 lbs	900 lbs	1,000 lbs
I.D.	19"	19"	19"	24"	24"	24"	27"	27"	27"
Drum Size	30 gal	30 gal	30 gal	55 gal	55 gal	55 gal	85 gal	85 gal	85 gal
Caster Rig	Zinc plate 4 swivel	Stainless 4 swivel	Stainless 4 swivel	Zinc plate 4 swivel	Stainless 4 swivel	Stainless 4 swivel	Zinc plate 4 swivel	Stainless 4 swivel	Stainless 4 swivel
3" Caster Wheel	Hard Rubber	Hard Rubber	White Polypropylene	Hard Rubber	Hard Rubber	White Polypropylene	Hard Rubber	Hard Rubber	White Polypropylene
Dolly Material	304 Stainless	304 Stainless	304 Stainless	304 Stainless	304 Stainless	304 Stainless	304 Stainless	304 Stainless	304 Stainless
Weight	20 lbs	20 lbs	18 lbs	22 lbs	22 lbs	21 lbs	24 lbs	24 lbs	23 lbs

Steel Drum Dollies

- **Wesco's Stability Advantage.** By design, Wesco casters are mounted past the dolly and drum rim. Our casters are centered under the dolly rim and further apart than standard designs which are inside the rim and closer together. The further the casters are apart, the greater the stability.
- All welded steel frame construction with reinforced outriggers.
- Four bolt on 3" swivel casters.
- I.D. varies among models.
- Models available for 30, 55, and 85 gallon drums.



D5-SI



4 swivel casters.

ASSEMBLED OVERALL DIMENSIONS - D3

w: 24"
h: 6"
d: 24"

ASSEMBLED OVERALL DIMENSIONS - D5

w: 28.5"
h: 6"
d: 28.5"

ASSEMBLED OVERALL DIMENSIONS - D8

w: 31.5"
h: 6"
d: 31.5"

Capacity	1,000 lbs	900 lbs	1,000 lbs	900 lbs	1,000 lbs	900 lbs
I.D.	19"	19"	24"	24"	27"	27"
Drum Size	30 gal	30 gal	55 gal	55 gal	85 gal	85 gal
Caster Rig	Zinc plate 4 swivel	Zinc plate 4 swivel	Zinc plate 4 swivel	Zinc plate 4 swivel	Zinc plate 4 swivel	Zinc plate 4 swivel
3" Caster Wheel	Sintered Iron	Hard Rubber	Sintered Iron	Hard Rubber	Sintered Iron	Hard Rubber
Dolly Material	Steel	Steel	Steel	Steel	Steel	Steel
Weight	18 lbs	18 lbs	24.5 lbs	22 lbs	26 lbs	26 lbs



Polypropylene Dolly

- 5 swivel casters, 3" polyolefin wheels.
- Handles 30 or 55 gallon drums.
- Rigid latticed understructure for strength.

OVERALL DIMENSIONS	
w:	24.25"
h:	7.125"
d:	24.25"



Specialty Dollies

- 3" hard rubber caster.
- Steel or aluminum designs.

OVERALL DIMENSIONS				
w:	24.5"	25.75"	24.5"	24.5"
h:	6"	6"	6"	6"
d:	24.5"	24.5"	24.5"	24.5"



PT Pail Truck

- Handles up to four standard steel or plastic 5-gallon pails.
- Ergonomic design eliminates the need to stack pails on a noseplate.
- 10" Semi-Pneumatic - **#150589**.

OVERALL DIMENSIONS	
w:	26"
h:	55"
d:	21"

Pail Tipper

- Adjustable chime hook.
- Ships KD easy assembly.
- Boxed dimensions 16.5"W x 22"D x 3"H.
- For dispensing 5 gal. steel or plastic pails.

OVERALL DIMENSIONS	
w:	14.5"
h:	30"
d:	14.5"

Part #	240201	240033	240040	240043	240044
Model #	P55-30-P	RSD	SSD*	RASD	RAOD
Capacity	900 lbs	900 lbs	900 lbs	900 lbs	900 lbs
I.D.	23.25"	24"	23.625" sq.	24"	24"
Drum Size	30 or 55 gal	55 gal	30 or 55 gal	30 or 55 gal	30 or 55 gal
Caster Rig	Zinc Plate 5 Swivel	Zinc plate 2 Rgd./2 Sw.	Zinc plate 4 swivel	Zinc plate 4 swivel	Zinc plate 4 swivel
3" Caster Wheel	Polyolefin	Hard Rubber	Hard Rubber	Hard Rubber	Hard Rubber
Dolly Material	Polypropylene	Steel	Steel	Aluminum	Aluminum
Weight	17 lbs	22 lbs	47 lbs	20 lbs	14 lbs

Part #	240042	273108
Model #	PT	PTR
Capacity	500 lbs	70 lbs
Brake	N/A	N/A
Wheels	Semi-Pneumatic	N/A
Weight	40 lbs	10 lbs



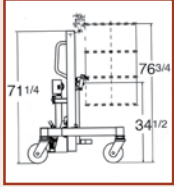
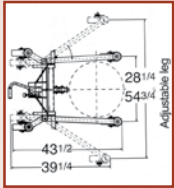

HLDT-880

High-Lift Hydraulic Drum Truck

- Handles 55, and 85 gallon drums.
- Easy width adjustment to accommodate a variety of pallets.
- Four 7 1/2" moldon polyurethane swivel casters.
- Locking rear casters.
- Works with most rimmed steel and poly drums.
- Not for use with open head drums or drums with lid rings.

OVERALL DIMENSIONS

w: 54.75"
h: 71.25"
d: 43.5"

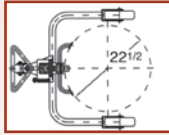
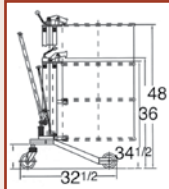
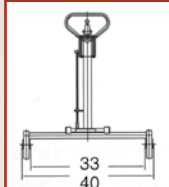

HDT-550

Economy Hydraulic Drum Truck

- Handles steel drums up to 22 1/2" in diameter.
- 2 rigid and 1 swivel locking caster for easy maneuverability.
- Pallet truck-type pump handle.
- Works with most rimmed steel drums.

OVERALL DIMENSIONS

w: 40"
h: 46"
d: 32.5"



PTDL

Pallet Truck Drum Drum Lifter

- Hydraulic pallet truck design to lift and move 55 gallon steel drums.
- Lowered height: 10"
- Raised height: 14.5"
- 8" x 2" nylon steering wheels.
- 1" x 3" nylon load wheels.

OVERALL DIMENSIONS

w: 28.5"
h: 47.5"
d: 42"



VDCD



Value Drum Carrier and Dispenser

- Economically priced.
- Three height adjustments: 9.25", 10.625" and 12".
- Vertical and horizontal locking positions.
- Polyurethane wheels and casters.
- 8" x 2" wheels and 4" x 1.25" caster.
- Ships KD.

OVERALL DIMENSIONS

w: 35"
h: 65.5"
d: 37"



500



Spill-Less Open Drum Truck

- Transport drums in a vertical position.
- Handles 55 gallon drums.
- 8" x 2" moldon rubber wheels with roller bearings.
- 5" x 2" polyolefin swivel casters.
- All welded construction.

OVERALL DIMENSIONS

w: 32"
h: 32.25"
d: 25.25"

Part #	272967	272945	273250	272404	240015
Model #	HLDT-880	HDT-550	PTDL	VDCD	500
Capacity	880 lbs	550 lbs	660 lbs	Full Drum - 800 lbs Half Drum - 500 lbs	1,000 lbs
Wheels	(4) 7.5" Polyurethane Swivel	(2) 8" Polyurethane Wheels (1) 5" Polyurethane Caster	(2) 8" x 2" Nylon Steering Wheels (2) 1" x 3" Nylon Load Wheels	(2) 8" x 2" Polyurethane Wheels (1) 4" x 1.25" Polyurethane Caster	(2) 8" x 2" Moldon Rubber w/ Roller Bearings (1) 5" x 2" Polyolefin Swivel Caster
Lift Height	76.75" to top of drum 42.5" to bottom of 34.5" steel drum	48" to top of drum 13.5" to bottom of 34.5" steel drum	N/A	N/A	N/A
Lift	0.45" per stroke	0.87" per stroke	N/A	N/A	N/A
Leg Span Adjustment	28.25" - 54.75"	N/A	N/A	N/A	N/A
Lift Range	42.5"	13.5"	N/A	N/A	N/A
Weight	220 lbs	99 lbs	115 lbs	105 lbs	70 lbs

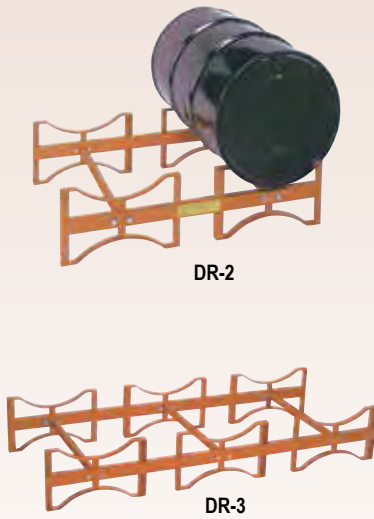

Drum Racks

- Two and three 55 gal. steel drum models.
- Four-side fork truck entry.
- Can be stacked 4 high.
- Standard models ship knocked down and boxed via UPS.
- Quick and easy to assemble.
- Welded and bolted construction.

OVERALL DIMENSIONS

w: 45.5"	71.5"
h: 12.5"	12.5"
d: 30"	30"



Deluxe Drum Cradle

- Tips, drains, stores, rotates and moves 30 or 55 gallon steel drums.
- Dual telescoping wood handles allow easy two handed control.
- Large 4" x 1.25" polyolefin wheels for easy movement over uneven floors.
- Shipped knocked down and boxed via UPS.
- **Backed by 2 year warranty against weld failure.**
- Drip tray option available.

OVERALL DIMENSIONS

w: 19"
d: 43" - 67.375"
h: 25.5"
20" drain height



Standard Steel Drum Cradles

- Economical and convenient way to tip, drain and store 55 gallon steel drums.
- Easy for one person to use.
- All models ship knocked down and boxed via UPS.
- Models available with 2.5" polyolefin wheels, self-storing load tipping lever, and swivel casters.
- Drip tray option available for all models

OVERALL DIMENSIONS

w: 19.5"
d: 32.5"
h: 15" on wheeled models
13.5" on non-wheeled models

Part #	240026	240027	240025	240022	240023	240024
Model #	DR-2	DR-3	CW-20	CW-10	CWO-10	CWS-10
Capacity	1,600 lbs (2 drums)	2,400 lbs (3 drums)	1,000 lbs	600 lbs	600 lbs	600 lbs
Wheels	N/A	N/A	(4) 4" x 1.25" Polyolefin Wheels	(4) 2.5" Polyolefin Wheels	(4) 2.5" Polyolefin Wheels	2.5" Polyolefin: (2) Wheels (2) Casters
Weight	49 lbs	64.5 lbs	50 lbs	30 lbs	32 lbs	34 lbs

Drip Tray

- Steel slide-out tray 9.75" x 9.75" with 1.75" lip.
- Fits all Wesco drum cradles.
- Polyethylene pan.
- Cellulose absorbent holds 3 quarts of liquid.

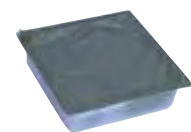
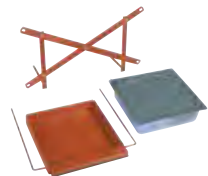

Part #	270413	270414
Model #	DT	DP
Weight	7.5 lbs	1 lb



EDL-5



Economy Drum Lifter

- Lightweight and easy to use.
- Lock pin design holds drum firmly in place.
- Ships boxed via UPS.
- For use with closed head 55 gallon steel drums.

OVERALL DIMENSIONS

w: 23.5"
h: 12.5"
d: 25.5"



Open head steel



Closed head steel



Open head poly

Open Head Drum Lifters

- For use with standard steel or poly drums with at least a 3/16" chime.
- Lifting arms are adjustable to work with most 55 or 30 gallon drums.
- Three-point contact of the lifting arms prevents or minimizes deformation of the drum and provides more secure lifting.
- Also works on closed head drums.

OVERALL DIMENSIONS

w: 29.5"
h: 5.5"
d: 29.5"



NOW AVAILABLE IN 304 STAINLESS STEEL



UDL



Universal Drum Lifter

- **Two models -**
UDL: carbon steel
UDL-SS: 304 stainless steel.
- Design allows for theloading of drums into overpacks.
- Works on open and closed head drums.
- For use with standard steel or poly drums with at least a 3/16" chime.
- Lifting arms are adjustable to work with most 55 or 30 gallon drums.
- Three-point contact of the lifting arms prevents or minimizes deformation of the drum and provides more secure lifting.

OVERALL DIMENSIONS

w: 29.5" 29.5"
h: 5.5" 5.5"
d: 29.5 29.5

Stainless



SDL-85



SDL-55



DRL-3

Salvage Drum Lifters

- Convenient for fast and gentle loading of steel drums into overpacks.
- Ships boxed via UPS.
- For use with closed head steel drums.

OVERALL DIMENSIONS

w: 9.875" 9.875"
h: 7.375" 7.375"
d: 19.63" 19.63"

Hoist Mount Drum Lifter

- Heavy duty annealed ductile iron.
- Curved foot on stabilizing arm prevents damage to drum.

OVERALL DIMENSIONS

w: 24.5"
h: 17.5"
d: 2.25"

Part #	240057	240038	240062	240063	240100	240102	440001
Model #	EDL-5	OHDL-3	UDL	UDL-SS	SDL-55	SDL-85	DRL-3
Capacity	700 lbs	1,000 lbs	1,000 lbs	1,000 lbs	1,000 lbs	1,000 lbs	3,000 lbs
Weight	17 lbs	18 lbs	20 lbs	21 lbs	20 lbs	18 lbs	37 lbs



**Value Lifter
VDL-55**

Value Drum Lifter/Dispenser

- Easily lift drum and dispense contents.
- Economical, lower capacity VALUE product.
- Ships assembled and boxed.
- Locks in horizontal or vertical position.
- Handles 55 gallon steel drums.

OVERALL DIMENSIONS

w: 8.5"
h: 36"
d: 29"

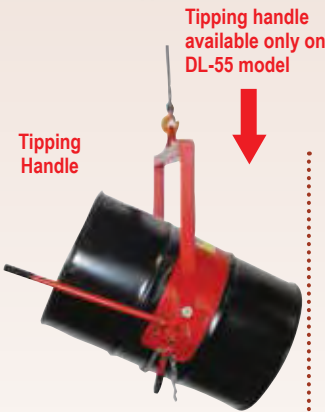

DL-55

Standard Drum Lifter/Dispenser

- Higher capacity quality product.
- Ships assembled and boxed.
- Easily lift drum and dispense contents.
- Locks in horizontal or vertical position.
- Handles 55 gallon steel drums.
- Over 25 years of proven reliable quality.

OVERALL DIMENSIONS

w: 8.5"
h: 36"
d: 29"



**Value Dispenser
VDGL-55**

Value Drum Lifter/Dispenser

- Economical, lower capacity VALUE product.
- Ships assembled and boxed.
- Locking control chain to secure drum from turning.
- Geared design for controlled dumping.

OVERALL DIMENSIONS

w: 28.5"
h: 39"
d: 8"



DGL-55

Deluxe Gear Controlled Drum Lifter/Dispenser

- Higher capacity quality product.
- Geared design for controlled dumping from many heights and angles.
- Locking control chain to secure drum from turning.
- See options FBA, DMG-30A.
- Ships assembled and boxed.

OVERALL DIMENSIONS

w: 28.5"
h: 39"
d: 8"



**DLS Drum Sling
440009 (steel)**

Drum Sling

- Horizontally lift all "closed or open-head" drums.
- D-shaped lifting ring fits most overhead systems.
- Inverted ring fits web-lifting slings.

OVERALL DIMENSIONS

w: 2.25"
h: 18.75"
d: 2"

Part #	440009	278750	240032	278751	240034	270402	270040
Model #	DLS-1000	VDL-55	DL-55	VDGL-55	DGL-55	FBA	DMG-30A
Capacity	1,000 lbs Steel	Full Drum - 700lbs Half Drum - 440 lbs	Full Drum - 800 lbs Half Drum - 500lbs	Full Drum - 700 lbs Half Drum - 440 lbs	Full Drum - 800 lbs Half Drum - 500 lbs	N/A	N/A
Weight	5 lbs	54 lbs	45 lbs	96 lbs	95.5 lbs	3 lbs	24 lbs



Option

- DMG-30A for use with 30 gallon drums, and FBA for use with fiber drums. For use with DL and DGL-55 models only.

WESCO® GATOR GRIP® DRUM GRAB



Gator Grip®

US PATENT NO. 6,619,905

Traditional devices require drum weight to maintain a positive lock. If a drum bounces during fork truck transportation, the drum may momentarily become weightless, which can cause the grip to snap open dropping the drum. The patented Auto Grip Lock automatically locks the jaws closed, even over rough terrain.



STEEL



FIBER



POLY



The Wesco Gator Grip Fork Truck Mounted Drum Grab is designed for lifting and transporting 16, 30, 55 and 85 gallon steel, fiber and poly drums.

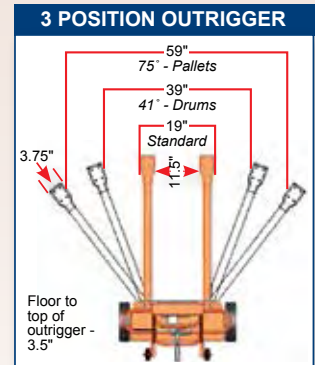

EGG-1



Fork Truck Carriage Mount - GG-C



Single Drum Fork Mount - GG-F1



Power Stacker Mount - GGPS

- Single grip / drum attachment.
- Mounts only to Wesco fork stacker carriage.



EGG-2



Dual Drum Fork Mount - GG-F2

- Fork truck fork attachment.
- Picks up drums automatically, driver never leaves seat while lifting or releasing drums.
- Handles steel, fiber and poly drums.
- Single and dual grips available.
- Gator Grips® made by Wesco.
- Economically priced.
- Patented Gator Grip®.
- Heavy-duty carriage design.
- Single and dual grips available.
- Fork truck attachment.
- Patented Gator Grip®.



Gator Belt Option - GGBK

- Optional Gator Belt protects drum from wear. **NOT AVAILABLE ON EGG MODELS.**



Triple Truck/ Drum Attachment

PATENT NO. US9,139,214B2

- Purchase as two parts. **FOR COMPLETE DETAILS, SEE PAGE 58.**
- Adjustable outriggers from 11.5" I.D. to 59" I.D.

OVERALL DIMENSIONS

w: 28"	33.25"	15.625"	32"	32"	18"	30"
h: 34"	34"	33.25"	37"	37"	33.25"	3"
d: 34"	34"	18"	28"	28"	17"	25"

Part #	240091	240092	240093	240096	240097	240103	240107	261160 & 261161
Model #	EGG-1	EGG-2	GG-C	GG-F1	GG-F2	GGPS	GGBK	TTF+TTF-GG
Capacity Per Grip	1,000 lbs	1,000 lbs	1,600 lbs	1,600 lbs	1,600 lbs	1,600 lbs	N/A	750 lbs
Fork Pocket ID	5.5" x 2"	7" x 2.25"	N/A	7" x 2.25"	7" x 2.25"	N/A	N/A	N/A
Weight	125.5 lbs	208 lbs	96 lbs	244 lbs	340 lbs	92 lbs	4 lbs	#261160 / 357 lbs #261161 / 32 lbs

Note: OSHA requires contacting the manufacturer of your fork truck for written approval for the use of any fork truck attachments.

**NOW FIVE MODELS
ALL WITH
U.S. PATENTED
GATOR GRIP®**

U.S. PATENT NO. 6,619,905

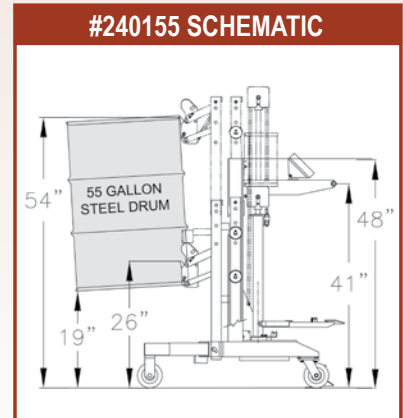
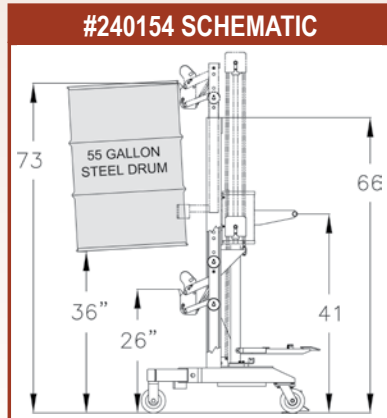
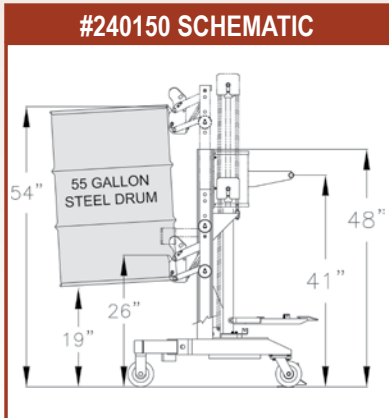
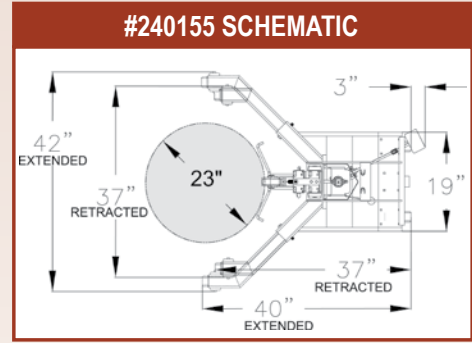
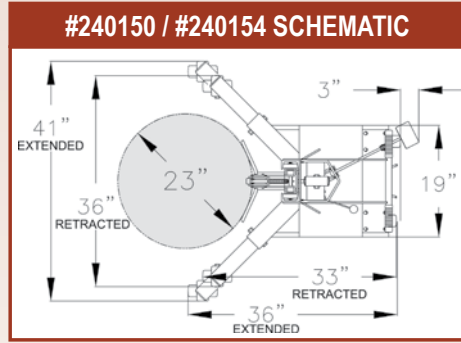

Wesco® Ergonomic Drum Handlers

- 1 Year Warranty, parts only.
- WESCO MADE hydraulic pump - all models.
- Handles most 30, 55 or 85 gallon drums - Steel, Fiber and Poly.
- Works with most drums with locking rings.
- Up/Down remote on power units.
- Power drive travel speed 120'/min.
- Lifts, transports, weighs and places drums on spill or standard pallets.
- (6) models: (5) steel and (1) 304 Stainless Steel.

- The (5) steel models are standard with the Gator Grip® Drum Clamp:
 - Spring-loaded jaws hold any 3/16" or higher drum rim.
 - Operator does not need to touch drums to operate.
 - Exclusive auto grip lock will not drop a drum if operated properly.
 - (2) wheels and (2) swivel casters, 5" x 2" phenolic, and floor lock.



Standard Model



High Reach Model



Scale Model - Accuracy ±0.50% of applied load or 1 lb., whichever is greater.

Part #	240150	240154	240155
Model #	DM-1100	DM-1100-HR	DM-1100-S
Description	Standard	High Reach	Scale
Rise/Stroke	1"	1"	1"
Legs Retracted Capacity	650 lbs	650 lbs	650 lbs
Legs Extended Capacity	1100 lbs	1100 lbs	1100 lbs
Drum Clamp Type	Gator Grip®	Gator Grip®	Gator Grip®
Weight	355.5 lbs	376 lbs	356 lbs

#240156 / #240157 SCHEMATIC

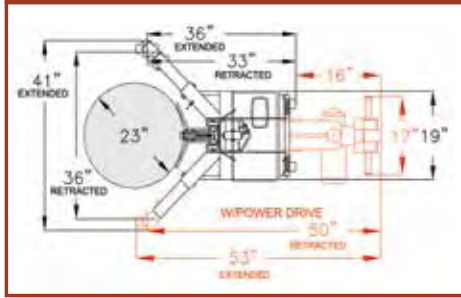

#240240 SCHEMATIC

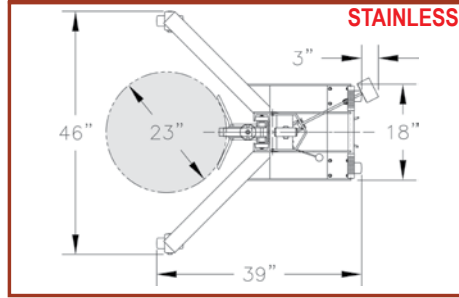

#240156 / #240157 SCHEMATIC

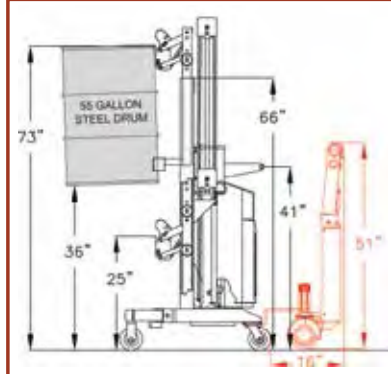

#240240 SCHEMATIC

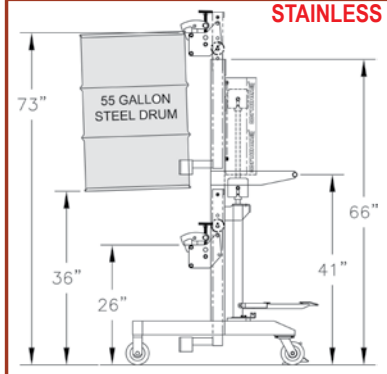

STEEL



FIBER



POLY



- The 304 Stainless Steel SSDH model features:
 - Wesco manufactured 304 Stainless Steel construction hydraulic jack.
 - 304 Stainless Steel automatic Grab that grips drum rim and can be manually locked down for lift and travel.
 - (2) 5" x 2" black phenolic wheels with 304 Stainless Steel roller bearings.
 - (2) 304 Stainless Steel NSF certified washdown swivel casters with 5" x 2" black phenolic wheels, 304 Stainless Steel bearings.

- Works with most drums with locking rings.
- Lift range: 26" - 73" at lifting clamp.
- Single position outriggers - non-telescoping
- 304 Stainless Steel construction includes hydraulic pump, floor lock, clamp, casters and bearings.
- Handles most 30, 55 and 85 gallon steel, poly and fiber drums.



Power Lift



Power Lift & Drive



304 Stainless Steel Drum Handler

Part #	240156	240157	240240
Model #	DM-1100-PL	DM-1100-PLD	SSDH
Description	Power Lift	Power Lift & Drive	304 Stainless High Reach
Rise/Stroke	8.5" / sec. without load	8.5" / sec. without load	1"
Legs Retracted Capacity	650 lbs	650 lbs	N/A
Legs Extended Capacity	1100 lbs	1100 lbs	800 lbs
Drum Clamp Type	Gator Grip®	Gator Grip®	Auto Grab Manual Knob Lock Down
Weight	531 lbs	691 lbs	207 lbs

WESCO DRUM GRABS/FORK TRUCK DRUM LIFTERS & TILTERS

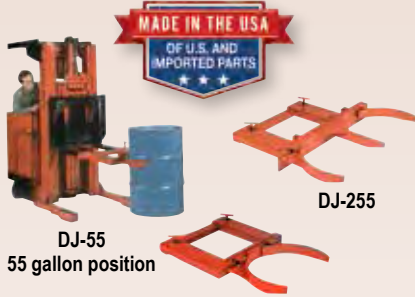

MADE IN THE USA
OF U.S. AND IMPORTED PARTS

DJ-55
55 gallon position

DJ-255



MADE IN THE USA
OF U.S. AND IMPORTED PARTS

ADJ-53
30 gallon position

Adjustable Drum Grabs for 55 or 30 Gallon Steel Drums

- ADJ models feature all welded steel construction for durability.
- Handles 55 or 30 gallon steel drums.

OVERALL DIMENSIONS

w:	28"	28"
h:	5.5"	5.5"
d:	41.75"	41.75"



SVG-55

SAVG-53

DVG-255

DAVG-253

Value Drum Grabs

- Economically priced lower capacity grabs.
- VG models: jaws not adjustable. Handles 55 gal. steel drums.
- AVG models: adjustable jaws. Handles 30 or 55 gal. steel drums.

OVERALL DIMENSIONS

w:	28"	46"	28"	51"
h:	4.5"	7.25"	5.5"	7.25"
d:	42.5"	43.25"	41.75"	42.75"

Drum Grabs for 55 Gallon Steel Drums

- All welded steel construction for durability.
- Cost effective way to move 55 gallon steel drums.

OVERALL DIMENSIONS

w:	28"	28"	46"
h:	4.75"	4.75"	7.25"
d:	42.75"	42.75"	43.25"

Part #	240048	270051	240049	240047	270084	272400	272401	272408	272409
Model #	DJ-55	DJL-55	DJ-255	ADJ-53	ADJL-53	SVG-55	DVG-255	SAVG-53	DAVG-253
Capacity	1,500 lbs/drum	1,500 lbs/drum	1,500 lbs/drum	1,500 lbs/drum	1,500 lbs/drum	1,000 lbs/drum	1,000 lbs/drum	1,000 lbs/drum	1,000 lbs/drum
Handles	one 55-gallon	one 55-gallon	two 55-gallon	one 55 or one 30 gallon	one 55 or one 30 gallon	one 55-gallon	two 55-gallon	one 55 or one 30 gallon	two 55 or two 30 gallon
ID Fork Pocket	5.5" x 2"	7" x 2.25"	7" x 2.25"	5.5" x 2"	7" x 2.25"	5.5" x 2"	7" x 2.25"	5.5" x 2"	7" x 2.25"
Weight	145 lbs	150 lbs	205 lbs	135 lbs	140 lbs	125 lbs	233 lbs	128 lbs	194 lbs



240039

MADE IN THE USA
OF U.S. AND IMPORTED PARTS

Fork Truck Drum Lifter & Tilter DGF-55

- Fork truck driver does not have to leave truck to dispense.
- Geared design allows controlled dumping and dispensing.
- Does not require any modifications to the fork truck.
- Ships assembled and boxed.
- Has 800 lbs capacity for a full drum, 500 lbs for a half full drum.
- Not for use with poly drums.
- Fork pocket dimensions (ID) 6.625"W x 2.625"H.
- Fork pocket dimensions center to center 31".
- Length of Chain 144".

OVERALL DIMENSIONS

w:	38"
h:	20.5"
d:	32.5"



240148

MADE IN THE USA
OF U.S. AND IMPORTED PARTS

Model PJ for most 30 and 55 gallon drums

Wesco Polyjaws

- Fork truck adjustable attachment for handling most 55 and 30 gallon poly drums.
- Fork truck driver does not have to leave cab to engage or disengage drum.
- Works on poly drums that have at least a 3/16" top lip (chime).
- Substantially lower priced than any other poly drum lifter on the market.
- Ships knocked down/ boxed via UPS.
- Fork pocket dimensions (ID) 5.375"W x 1.5"H.

OVERALL DIMENSIONS

w:	25.5" -29.375"
h:	6.28"
d:	21.38"



VFDLT-1400

Value Fork Truck Drum Lifter & Tilter

- Economically priced lower capacity model.
- Two models, 700 & 1,400 lb capacities.
- Operator does not have to leave seat to tilt drum.
- Fork pocket dimensions (ID) 7" W x 2.5"H.
- Fork pocket dimensions center to center 24.4".
- Length of Chain 120".

OVERALL DIMENSIONS

w:	39"	39"
h:	19"	19"
d:	26.75"	30.38"

Part #	240039	270240	270402	240148	272402	272403
Model #	DGF-55	DGF-30A	FBA	PJ	VFDLT-700	VFDLT-1400
Capacity	55 GAL. DRUM UNIT Half Drum - 500 lbs Full Drum - 800 lbs	30 GAL. DRUM ADAPTER Half Drum - 500 lbs Full Drum - 800 lbs	FIBER DRUM ADAPTER Half Drum - 500 lbs Full Drum - 800 lbs	1,000 lbs	Half Drum - 440 lbs Full Drum - 700 lbs	Half Drum - 750 lbs Full Drum - 1,400 lbs
Weight	159 lbs	24 lbs	3 lbs	44 lbs	166 lbs	214 lbs

Note: OSHA requires contacting the manufacturer of your fork truck for written approval for the use of any fork truck attachments.

Zinc Die Cast Faucets

- Zinc die cast alloy.
- Easy-to-use self-closing design.
- Can be padlocked in closed position.
- .75" NPT connection.
- Viton gasket.



Part# 272083 - .53 lbs.
 With flame arrestor.
FM APPROVED for non-viscous liquids.



Part# 272080 - .53 lbs.
 No flame arrestor.
FM APPROVED for viscous liquids only.

Heavy Duty 2" Brass Gate Valve

- Fast, self-closing PTFE blade.
- 2" NPSM connection designed to work in both a straight or tapered thread.
- 6.80 lbs.



Part# 272034
FM APPROVED for use with viscous non-corrosive fluids heavier than 30 SAE.

Heavy Duty 304 Stainless Steel Faucet

- Adjustable shank designed to easily adjust to proper drain position after installing in drum.
- .75" NPT connection.
- PTFE gasket.
- 1.50 lbs.



Part# 272038
 Internal flame arrestor.
FM APPROVED for use with oils (under 30 SAE) and non flammables, compatible with stainless steel.

Heavy Duty Brass Faucets

- Easy-to-use self-closing design.
- .75" NPT connection.
- PTFE gasket.



Part# 272037 - 1.40 lbs.
 Adjustable shank designed to easily adjust to proper drain position after installing in drum.
 Internal flame arrestor.
FM APPROVED for use with oils (under 30 SAE) and non-corrosive flammables.



Part# 272081 - 1.43 lbs.
 Rigid shank design.
 External flame arrestor.
FM APPROVED for use with oils (under 30 SAE) and non-corrosive flammables.

Plastic Faucets

- 2" NPT polyethylene drum faucet produced from **FDA approved material**. Includes 3 EPDM sealing gaskets: thin, medium, thick. Good for viscous non-corrosive fluids.
- .83 lbs.



Part# 272176 - 2"

- Deluxe 2" NPT polyethylene drum faucet. Produced from **FDA approved material**.

Deluxe features:

- Level gauge port
- Pail hook
- Lockable handle
- 3 EPDM gaskets: thin, medium, thick.

- 1 lb.



Part# 272179 with level gauge



Part# 272179 - 2"

- .75" Polyethylene Faucet for use with non-flammable, non-corrosive thin liquids not suitable for heavy oils.

- .10 lbs.



Part# 272177 - .75"

Wesco recommends that if a question arises, the user contact the supplier of chemicals to determine if these faucets are compatible with those chemicals. Wesco is unable to offer specific recommendations for chemical usage.

Drum Vent

- Automatically relieves pressure at 5 PSI.
- Maximum flow of 220 CFM at 20 PSI.
- Flame arrestor prevents sparks and flame from igniting drum contents.
- Fits 2" bung hole in steel and plastic drums.
- 1 lb.



Part# 272030
 For drums in horizontal (pouring) position. Manual vacuum relief by lifting and rotating valve stem.
FM APPROVED.

Gauges

- Economical way to gauge drum contents.
- Heavy gauge glass and plated steel construction.
- Accepts standard .75" NPT faucet.
- Buna-N seals; .75" NPT connection, 22" height (with supplied fitting).



Part# 272005 - 2.16 lbs.
 Basic gauge with fitting.



Part# 272006 - 4 lbs.
 Basic gauge with fitting and 272080 faucet.

Part# 272041 - 5 lbs.
 Basic gauge with fitting and 272083 faucet.

Part# 272115 -
 Replacement glass for gauge.

Drum Funnel with Lockable Cover

- Red polyethylene 4-quart funnel with 2" NPS fitting to screw into bung opening.
- 9.625" opening.
- Equipped with black polyethylene lockable cover and removable strainer screen.
- 1.1 lbs.



Part #272140 Model #DF



Vertical Polyethylene Pop-up Gauge

- Pops up to indicate drum is almost full.
- Fits standard 3/4" - 14 NPS bung holes.
- Part #272216, Model # PUG-5 - 5" long.
- Part #272217, Model # PUG-11 - 11" long.
- Closure cap.



Ground and Bond Wires

- A wide variety of designs for grounding and bonding applications.



Part# 272032 - .64 lbs
 Deluxe Ground Wire: For connection between drum and true ground. Three-foot-long heavy duty insulated wire rope with "C" clamp on one end and alligator clip on the other.



Part# 272031 - .53 lbs
 All Purpose Bond Wire: For bonding drums to each other, to containers being filled, and to racks. Three-foot-long heavy duty wire rope with "C" clamp on one end and alligator clip on the other.



Part# 272033 - .37 lbs
 Standard Bond Wire: For bonding drums to each other, to containers being filled, and to racks. Three-foot-long heavy duty wire rope with alligator clips on both ends.

OSHA requires that all drums and containers storing and receiving fluids with a FLASH POINT BELOW 140°F be grounded and bonded. Single drums must be grounded, with containers being dispensed into bonded to the drum. Multiple drums must be bonded to each other with one drum or the rack grounded. Wesco Ground and Bond wires allow meeting these important safety requirements.

Deheaders

- Open any size and gauge steel drum quickly and easily, allowing drum recycling without the risk of fire from cutting with a torch.
- Sharp-edged hardened steel replaceable blade.
- Comfortable plastic hand grip.



Part# 272303
Vertical slide deheader. (6.2 lbs.)
Part# 272304 Replacement blade. (1 lb.)



Part# 272018
Most popular deheader. (7 lbs.)

Part# 272012
Replacement blade. (.73 lbs.)

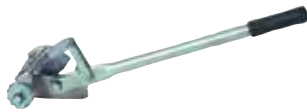

Part# 440013 Model DDH-1.
Heavy duty deheader. (9 lbs.)

Part# 440014 Model DDH-P202
Replacement blade. (.60 lbs.)

Non-Sparking Deheader

- 100% non-sparking deheader.
- Sharp-edged hardened non ferrous alloy replaceable blade.
- Comfortable plastic hand grip.



Part# 272301
Non-sparking deheader.
100% non-sparking. (8 lbs.)

Part# 272302
Replacement blade. (.35 lbs.)

Universal Drum Plug Wrench

- Heavy duty cast iron construction.
- Opens most plugs and bung nuts, male & female, steel & plastic.
- Iron alloy will not chip or bend in normal use.
- Protects knuckles.



Part# 272017
(4 lbs.)
Handles bung patterns
1, 2, 3, & 4.

Bung Patterns

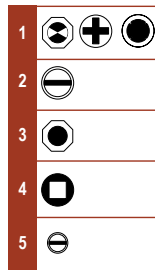

Non-Sparking Drum Plug Wrenches

- Bronze alloy.
- Stronger than aluminum.
- Offset handle design reduces user stress and minimizes knuckle injury.



Part# 272016
(2 lbs.)
Our most popular wrench.
Handles bung patterns
1, 2, 3, & 5.



Part# 272178
(.53 lbs.)
Aluminum Non-Sparking Drum Wrench.
Handles bung patterns 1 & 3.



Part# 272086
(3 lbs.)
Deluxe model. Built-in 1.25" wrench for tightening faucets into drums. Handles bung patterns 1, 2, 3, & 5.

Part #	Description	Weight - lbs	Overall Width	Overall Height	Overall Length
272303	Vertical slide deheader	6.20	5.75"	5.875"	17.75"
272304	Replacement blade for Part# 272303	1.00	2.75"	2.75"	.1875"
272018	Manual drum deheader	7.00	6"	4.25"	20.68"
272012	Replacement blade for Part# 272018 deheader	.73	2.75"	2.50"	.1875"
440013	Zinc plated heavy duty deheader	9.00	6.375"	4.625"	23.625"
440014	Replacement blade for Part# 440013 deheader	.60	3.1875"	2.875"	.1875"
272301	Non-sparking deheader	8.00	6.625"	4.875"	19"
272302	Replacement blade for Part# 272301 deheader	.35	2.875"	2.375"	.1875"
272017	Universal cast iron drum wrench	4.00	3.625"	3.50"	13.125"
272016	Standard non-sparking drum wrench	2.00	2.50"	3.25"	12"
272178	Non-sparking aluminum wrench	.53	2.25"	1.75"	10.25"
272086	Deluxe non-sparking drum wrench	3.00	3.625"	3.125"	11.50"

Application Information (For Rotary and Lever Pumps): WESCO iron drum pumps have wetted parts fabricated from cast iron, steel, phenolic (270021 & 272212 only), and neoprene (272210 only) materials. These pumps were designed primarily for the transfer of fuel oil products. It should be noted that these pumps can only be used for chemicals which are compatible with cast iron, steel, neoprene and phenolic.

We recommend that if a question arises, the user contact the supplier of chemicals to determine if these pumps are compatible with those chemicals. WESCO is unable to offer specific recommendations for chemical usage.

Rotary Pump

- 47" 3 piece plated suction tube (assembled).
- Durable phenolic veins.
- Self-priming.
- Supplied with 48" PVC discharge tube.
- UPS shippable.
- Rugged cast iron construction.
- ALWAYS USE A GROUND WIRE.



Part# 272212
Deluxe Combo (consists of #270021 Rotary Pump and #272211 Drip Pan) (18 lbs.)

Part# 270021
Cast Iron Rotary Drum Pump ONLY (12.5 lbs.)

Non-Sparking Rotary Pump

- Rugged aluminum construction.
- 47" 3 piece steel-plated suction tube (assembled).
- Durable phenolic veins.
- Self-priming.
- Supplied with 48" PVC discharge tube.
- UPS shippable.
- ALWAYS USE A GROUND WIRE.



Aluminum Pump only.

Part# 440017
Aluminum, non-sparking for medium viscosity petroleum-based products. Does not include drip pan. (17 lbs.)



Part# 272210
(18 lbs.)

Lever Pump/ Drip Pan

- For installation on pumps with metal suction tube.
- Cast iron and steel construction.
- Hinged cover and bung/suction adapter.
- UPS shippable.
- ALWAYS USE A GROUND WIRE.



Part# 272211
Drip pan. (6 lbs.)



Part# 272397
(13 lbs.)

304 Stainless Steel Rotary Pump

- Made from corrosion resistant materials of construction.
- 304 stainless steel pump body.
- 304 stainless steel dispensing spout.
- 304 stainless steel 3 piece suction tube.
- PTFE vanes.
- UPS shippable.
- Compatible fluids: solvents, oils, mild corrosives.
- Min./ Max. temperature rating: 40° Fahrenheit / 140° Fahrenheit.
- 2" NPT Bung Adapter fits 15, 30 and 55 gallon drums.
- ALWAYS USE A GROUND WIRE.

Part #	Description	Weight - lbs	Overall Width	Overall Height	Overall Length
270021	Cast iron pump	12.50	9.4375"	56.25"	8.75"
272212	Deluxe combo with drip pan	18.00	9.4375"	56.25"	14"
440017	Non-sparking rotary pump	17.00	9.4375"	56.25"	9.50"
272210	Lever pump with drip pan	18.00	15.875"	60.343"	14"
272211	Drip pan	6.00	6.3125"	6.00"	14"
272397	304 stainless steel rotary pump	13.00	9.125"	53.125"	8.75"

A 5 Year Guarantee Against Weld Failure. A Wesco Quality Exclusive.

- Industrial strength heavy duty 3/4" structural steel frame construction.
- Ribbed cross braces for extra strength.
- All joints double welded.
- 8" deep by 14" wide nose is 7 gauge thick plate with machined beveled edge and radiused corners for safety.
- Zinc plated Auto-Loc® axles assure smooth wheel rotation.
- All frames handle 8" or 10" wheels.
- Order by part # or model #.

Example:

Part # or Model #
210009 or 126-R

Wesco Exclusive: Ribbed Cross Straps for Additional Strength



126-Z

Series 126

- Single pin handle curved back design allows one hand control.
- Ideal for boxes, kegs, and packages.
- Three horizontal cross straps and full height vertical center strap offer support for small packages.

OVERALL DIMENSIONS

w: 22.5"
h: 46"
d: 16.5" w/8" wheel 18.5" w/10" wheel



126D-Z8

Series 126D

- Single "D" shaped handle allows multiple hand positions for one hand control.
- Ideal for boxes, kegs, and packages.
- Three horizontal cross straps and full height vertical center strap provide support for small packages.

OVERALL DIMENSIONS

w: 22.5"
h: 46"
d: 16.5" w/8" wheel 18.5" w/10" wheel



136-Z

Series 136

- Two handle tapered body design.
- Three heavy duty horizontal cross straps for added strength.
- Full height center strap provides support for small packages.

OVERALL DIMENSIONS

w: 22.5"
h: 46"
d: 16.5" w/8" wheel 18.5" w/10" wheel

Part #	210009	210010	210011	210380	210012	210370	210016	210017	210018	210381	210019	210371	210024	210025	210026	210382	210027	210372
Model #	126-R	126-Z8	126-Z	126-Z2	126-P	126-PE	126D-R	126D-Z8	126D-Z	126D-Z2	126D-P	126D-PE	136-R	136-Z8	136-Z	136-Z2	136-P	136-PE
Capacity	800 lbs	600 lbs	700 lbs	800 lbs	700 lbs	700 lbs	800 lbs	600 lbs	700 lbs	800 lbs	700 lbs	700 lbs	800 lbs	600 lbs	700 lbs	800 lbs	700 lbs	700 lbs
Wheel Type	R	Z8	Z	Z2	P	PE	R	Z8	Z	Z2	P	PE	R	Z8	Z	Z2	P	PE
Weight	32 lbs	38 lbs	40 lbs	40 lbs	37 lbs	34 lbs	33 lbs	39 lbs	41 lbs	41 lbs	38 lbs	35 lbs	33 lbs	39 lbs	41 lbs	40 lbs	39 lbs	34 lbs

Additional choices not listed above.

R Aluminum 8" x 1.625" Moldon Rubber	Z8 Poly Offset 8" x 2" Solid Rubber	Z Steel Offset 10" x 2.75" Semi-Pneumatic	Z2 Poly Offset 10" x 2.75" Solid Rubber	P Steel Offset 10" x 3.5" Pneumatic	PE Steel Offset 10" x 3.5" Pneumatic	BC-8 Poly Hub 8" x 2.165" Balloon Cushion	BC-10 Poly Hub 10" x 2.165" Balloon Cushion	CF (Flat Free) Steel Offset 10" x 3" Microcellular
108545	150697	150589	150698	050602	151551	150229	150228	053446

HAND TRUCKS

WESCO® 100 SERIES INDUSTRIAL HAND TRUCKS

A 5 Year Guarantee Against Weld Failure. A Wesco Quality Exclusive.
Wesco Exclusive: Ribbed Cross Straps for Additional Strength



Series 146

- Two handle extra high back curved design.
- Ideal for high loads.
- Four horizontal cross straps and vertical center strap provide support for small packages.

OVERALL DIMENSIONS

w: 22.5"
 h: 51"
 d: 16.5" w/8" wheel 18.5" w/10" wheel



Series 146D

- Single "D" shaped handle combined with high back curved design.
- Easier one hand control of stacked goods.
- Four horizontal cross straps and vertical center strap provide support for small packages.

OVERALL DIMENSIONS

w: 22.5"
 h: 51"
 d: 16.5" w/8" wheel 18.5" w/10" wheel



156-Z
Steel



156-PP8-SS
304 Stainless Steel

Series 156

- Swept back continuous handle with curved back design.
- Versatile frame that allows one or two hand control.
- Four horizontal cross straps and vertical center strap provide support for small packages.
- **Stainless** model has 8" x 2" polyurethane tread on polypropylene hub, non-marking wheels with 440 stainless sealed 3/4" precision ball bearing

OVERALL DIMENSIONS

w: 22.5"
 h: 48"
 d: 16.5" w/8" wheel 18.5" w/10" wheel

304
Stainless

Part #	210032	210033	210034	210383	210035	210373	210038	270056	210039	210384	210040	210374	210044	210045	210046	210385	210047	210375	210351
Model #	146-R	146-Z8	146-Z	146-Z2	146-P	146-PE	146D-R	146D-Z8	146D-Z	146D-Z2	146D-P	146D-PE	156-R	156-Z8	156-Z	156-Z2	156-P	156-PE	156-PP8-SS
Capacity	800 lbs	600 lbs	700 lbs	800 lbs	700 lbs	700 lbs	800 lbs	600 lbs	700 lbs	800 lbs	700 lbs	700 lbs	800 lbs	600 lbs	700 lbs	800 lbs	700 lbs	700 lbs	600 lbs
Wheel Type	R	Z8	Z	Z2	P	PE	R	Z8	Z	Z2	P	PE	R	Z8	Z	Z2	P	PE	PP8
Weight	34 lbs	40 lbs	42 lbs	42 lbs	39 lbs	36 lbs	35 lbs	41 lbs	43 lbs	42 lbs	41 lbs	36 lbs	34 lbs	37 lbs	39 lbs	40 lbs	36 lbs	34 lbs	33 lbs

100 Series Industrial Hand Truck Options



Nose Extension

- 24" long, 10.5" wide.
- Steel construction.



Stairclimber

- Continuous belt.
- Replaceable parts.
- Only available on 10" wheeled models.
- Factory installed only.



Cargo Push-Off Kit

- Fits any Wesco 100 Series or Greenline Series steel hand trucks.
- Foot operated pedal pushes cargo off noseplate.
- Easy installation - no drilling required.

Part #	210099	054201	270412	210079
Model #	FN-24K	FN-24F	CBSCF	
	24" Nose Extension - Field Installation	24" Nose Extension - Factory Installed	Continuous belt stairclimber Must be Factory Installed	Box Push Off - Field Installation
Weight	4 lbs	4 lbs	7 lbs	6 lbs

FACTORY INSTALLED add part # or model # to end of industrial hand truck part or model #.
EXAMPLE: 156R with 24" nose extension Part # 210044,054201 or Model #156-R-FN-24F.

PP8 8" x 2" Polyurethane Tread Polypropylene Hub 3/4" Ball Bearing	R Aluminum 8" x 1.625"	Z8 Poly Offset 8" x 2"	Z Steel Offset 10" x 2.75"	Z2 Poly Offset 10" x 2.75"	P Steel Offset 10" x 3.5"	PE Steel Offset 10" x 3.5"	BC-8 Poly Hub 8" x 2.165"	BC-10 Poly Hub 10" x 2.165"	CF (Flat Free) Steel Offset 10" x 3"
053733	108545	150697	150589	150698	050602	151551	150229	150228	053446

Additional choices not listed above.



SINCE 1948



156-S23-Z2

2-in-1 Deluxe Industrial Steel Hand Trucks*

- **5 Year Weld Guarantee.**
- Converts easily between 2 and 4 wheel truck.
- Handle locks in horizontal and vertical positions.
- Two lengthwise straps and two cross braces prevent package fall-through.
- Caster: 3.5" TPR gray, non-marking, round tread, thermoplastic rubber wheel resists almost every type of floor debris including metal shavings chips, sand and gravel.
- Heavy duty 3/4" Dia. structural steel frame. All joints double welded, both sides.
- Bed size: 14" x 44.5".
- Noseplate 14"W x 8"D.
- Less energy required to start moving load and keep it moving.
- Smooth, quiet ride of a soft-tread wheel, durable as a hard-tread wheel.

OVERALL DIMENSIONS

w: 20.5"
h: 53"
d: 19"

Curb Ramp

- Lightweight, portable ramp allows for easy movement up and down curbs. **600 lb capacity.**



OVERALL DIMENSIONS

w: 21.5"
h: 6"
d: 23.5"

Part #	150800
Description	Yellow generic
Weight	7 lbs



656-21-Z

Greenline Economical 2-in-1

- Converts easily between 2 and 4 wheel truck.
- Double welded tubular construction.
- Lengthwise strap and cross braces prevent package fall-through.
- Solid rubber swivel casters.
- Bed size 13" x 36".
- 14" W x 7" D noseplate.

OVERALL DIMENSIONS

w: 20"	20"	20"	20"
h: 48"	48"	48"	48"
d: 15"	16"	16"	16"



E-CON

Greenline E-Con 2-in-1 Truck

- Heavy duty tubular steel construction.
- 18"w. x 8.5"d. noseplate.
- Lever activated position conversion.
- Wheel guards.
- Bed size - 13.75" x 48".
- Wheel: 10" x 2.75" solid rubber.
- Swivel caster: 5" x 1.375" moldon polyurethane.

OVERALL DIMENSIONS

w: 19.5"
h: 58"
d: 18"

Part #	210138	210140	210139	210321	210324	210326	210325	210639
Model #	156-S23-Z	156-S23-Z2	156-S23-P	656-21-Z8	656-21-Z	656-21-Z2	656-21PE	E-CON
Capacity								
2 wheel	700 lbs	800 lbs	700 lbs	500 lbs	500 lbs	500 lbs	500 lbs	700 lbs
4 wheel	1,000 lbs	1,000 lbs	1,000 lbs	600 lbs	600 lbs	600 lbs	600 lbs	800 lbs
Caster	3.5"	3.5"	3.5"	5"	5"	5"	5"	5"
Wheel Type	Z	Z2	P	Z8	Z	Z2	PE	10" x 2.75" Solid Rubber
Weight	61 lbs	58 lbs	55 lbs	37 lbs	46 lbs	44 lbs	38 lbs	74 lbs

Z8	Z	Z2	PE	P
Poly Offset 8" x 2" Solid Rubber	Steel Offset 10" x 2.75" Semi-Pneumatic	Poly Offset 10" x 2.75" Solid Rubber	Steel Offset 10" x 3.5" Pneumatic	Steel Offset 10" x 3.5" Pneumatic
150697	150589	150698	151551	050602



*** For Aluminum Convertible Trucks, see pages 34-36.**

WESCO GREENLINE STANDARD DUTY STEEL HAND TRUCKS

- Economically priced.
- Zinc plated Auto-Loc® axles assure smooth wheel rotation.
- All frames can accommodate an 8" or 10" wheel.

- 7" deep x 14" wide 7 gauge beveled nose plate with radiused corners for safety.
- 1" OD x 14 gauge wall tubular frame.

- Order by part # or model #.

Example:

Part # or Model #
210461 626-Q

Series 626

- Pin handle with curved back design.
- Welded frame construction.
- 1" O.D. tube.

OVERALL DIMENSIONS

w: 21.75"
h: 45.5"
d: 17"



626-Z8

Series 626D

- Single loop handle with curved back design.
- Welded frame construction.
- 1" O.D. tube.

OVERALL DIMENSIONS

w: 21.75"
h: 50.5"
d: 17"



626D-R

Series 636

- Dual handle curved back design.
- Welded frame construction.
- 1" O.D. tube.

OVERALL DIMENSIONS

w: 21.75"
h: 48.5"
d: 17"



636-Z8

Part #	210466	210330	210361	210456	210356	210467	210331	210362	210457	210357	210468	210332	210363	210458	210358
Model #	626-R	626-Z8	626-Z2	626-P	626-PE	626D-R	626D-Z8	626D-Z2	626D-P	626D-PE	636-R	636-Z8	636-Z2	636-P	636-PE
Capacity	600 lbs	500 lbs	600 lbs	600 lbs	600 lbs	600 lbs	500 lbs	600 lbs	600 lbs	600 lbs	600 lbs	500 lbs	600 lbs	600 lbs	600 lbs
Wheel Type	R	Z8	Z2	P	PE	R	Z8	Z2	P	PE	R	Z8	Z2	P	PE
Weight	25.5 lbs	25.5 lbs	31 lbs	27.5 lbs	26 lbs	27 lbs	27 lbs	36 lbs	29 lbs	27.5 lbs	26 lbs	26 lbs	31.5 lbs	28 lbs	26.5 lbs

Series 646

- Dual pin handle with curved back design.
- Welded frame construction.
- 1" O.D. tube.

OVERALL DIMENSIONS

w: 21.75"
h: 50.5"
d: 20"



646-Z2

Series 656

- Continuous handle with curved back design.
- Welded frame construction.
- 1" O.D. tube.

OVERALL DIMENSIONS

w: 21.75"
h: 49"
d: 19"



656-P

Folding Nose Extension Option

- To order field installation simply note part # or model # on P.O.
- To order factory installed option (626D-R with 24" nose extension) add option part # or model to the end of the truck part # or model.



Example:

Part # 210467,054218
or
Model + Option
626D-R-FNG-24F

Part #	210469	210333	210364	210459	210359	210470	210334	210365	210460	210360	210249	054218
Model #	646-R	646-Z8	646-Z2	646-P	646-PE	656-R	656-Z8	656-Z2	656-P	656-PE	FNG-24K	FNG-24F
Capacity	600 lbs	500 lbs	600 lbs	600 lbs	600 lbs	600 lbs	500 lbs	600 lbs	600 lbs	600 lbs	Capacity rating same as truck.	
Wheel Type	R	Z8	Z2	P	PE	R	Z8	Z2	P	PE	Field Installation	Factory Installed
Weight	27 lbs	27 lbs	32.5 lbs	29 lbs	27.5 lbs	27.5 lbs	27.5 lbs	33 lbs	29.5 lbs	28 lbs	4 lbs	4 lbs

Additional choices not listed above.

R	Z8	Z2	P	PE	BC-8	BC-10	CF (Flat Free)	Z
Aluminium 8" x 1.625" Moldon Rubber	Poly Offset 8" x 2" Solid Rubber	Poly Offset 10" x 2.75" Solid Rubber	Steel Offset 10" x 3.5" Pneumatic	Steel Offset 10" x 3.5" Pneumatic	Poly Hub 8" x 2.165" Balloon Cushion	Poly Hub 10" x 2.165" Balloon Cushion	Steel Offset 10" x 3" Microcellular	Steel Offset 10" x 2.75" Semi-Pneumatic
108545	150697	150698	050602	151551	150229	150228	053446	150589

*A 5 Year Guarantee Against Weld Failure.
A Wesco Quality Exclusive on All Wesco Made Hand Trucks.*

■ Structural steel frame construction.

■ Ribbed x-braces for extra strength.

■ All joints double welded.

The Touch-N-Tilt® Ergonomic Hand Truck

Press the pedal and the effort to break over the load is reduced by as much as 66%. Minimizes physical demands of the workplace.



TNT56-Z

Push a pedal and your load feels lighter – 66% lighter

Touch-N-Tilt®

- Simple and affordable.
- Up to 700 lbs. capacity.
- Available with 8" or 10" wheels.
- Same strong frames used on Wesco 100 series industrial truck.
- Noseplate 7 GA. 8" D x 14" W.

OVERALL DIMENSIONS

w: 20"	22"	22"
h: 50"	50"	50"
d: 19.75"	19.75"	19.75"



156DH-Z

156DH-PP8-SS

304 STAINLESS STEEL

156DH Drum/Hand Truck

- Utility of a hand truck & drum truck.
- Chime hook works with 55 and 30 gallon steel drums.
- Curved frame holds 5-gallon pails and kegs.
- With noseplate resting flat on floor, 18" to center of lowered chime hook.
- Noseplate 7.8" D x 14" W.
- Stainless model has 8" x 2" polyurethane tread on polypropylene hub, non-marking wheels with 440 stainless sealed 3/4" precision ball bearing.

OVERALL DIMENSIONS

w: 20.5"	20.5"	20.5"
h: 48"	48"	48"
d: 18.5"	17.5"	18.5"

304 Stainless

NEW!



4-Wheel Drum Cart

- Two position, 4-wheel transport design to handle drums and standard loads.
- **Position I:** Easily handles and maneuvers standard loads as a 4-wheel transport.
- **Position II:** With the chime hook engaged and a press of the foot pedal, the frame tilts a 30 or 55 gallon steel drum to a balanced position to maintain 4-wheel contact even with half empty bottom heavy drums.
- Two 3.5" x 1.5" polyolefin swivel casters for easy maneuverability in narrow spaces.
- Chime hook to engage 30 & 55 gallon steel drums.
- 7.8" D x 14" W beveled edge noseplate.
- Curved frame holds 5-gallon pails and kegs.

OVERALL DIMENSIONS

w: 19.25"	19.25"
h: 26.25"	48.5"
d: 48"	25"

Part #	210546	210549	210547	210340	210349	210266	210352	210353	210354
Model #	TNT56-Z	TNT56-Z2	TNT56-P	156DH-Z	156DH-HB	156DH-P	156DH-PP8-SS	4WDC-ZC	4WDC-HBC
Capacity	600 lbs	700 lbs	600 lbs	700 lbs	800 lbs	700 lbs	600 lbs	800 lbs	900 lbs
Wheel Type	Z	Z2	P	Z	HB	P	8" Polyurethane	10" Z	8" HB
Weight	41.5 lbs	42 lbs	38.5 lbs	39 lbs	42.5 lbs	39 lbs	33.5 lbs	66 lbs	66 lbs

PE	SR	Z	HB	Z2	P	PP8
Steel Offset 10" x 3.5" Pneumatic	Poly Offset 10" x 2.5" Solid Rubber	Steel Offset 10" x 2.75" Semi-Pneumatic	Cast Iron 8" x 2" Moldon Rubber	Poly Offset 10" x 2.75" Solid Rubber	Steel Offset 10" x 3.5" Pneumatic	8" x 2" Polyurethane Tread Polypropylene Hub 3/4" Ball Bearing
151551	108479	150589	150120	150698	050602	053733

HAND TRUCKS

WESCO® HEAVY DUTY STEEL HAND TRUCKS

A 5 Year Guarantee Against Weld Failure. A Wesco Quality Exclusive.



Oversized 12" pneumatic tire for easy mobility on rough terrain.



ST2-P12

Heavy Duty Shovel Nose Trucks

- Five year weld guarantee.
- 13" deep x 17.5" x .25" thick tapered nose plate.
- 1" heavy duty structural steel frame.
- Easy grip continuous handle frame design.
- 3/4" axle.
- Wheel guards.
- 2 wheel types - 8" & 12".

OVERALL DIMENSIONS

w:	20.5"	20.5"
h:	53"	53"
d:	22"	25.5"



Swivel caster →

186-ZC

Heavy Duty 186 Series

- Rear caster design allows small diameter turns in tight areas.
- Combination two handle and utility bar handle design.
- Distribution of load over 4 wheels improves load control.
- All wheels have ball bearings.
- Wheel guards.

OVERALL DIMENSIONS

w:	20.5"	d: 8"
h:	48"	
d:	25"	

NOSE PLATE

d: 8"



Steel Reinforced on underside of nose plate.

146RN-HB

Heavy Duty Hand Truck

- 8" x 2" cast iron center moldon rubber wheels.
- 7.25" x 14" steel reinforced nose plate.
- .75 inch axle.
- Five handle choices.

OVERALL DIMENSIONS

w:	19.625"
h:	51"
d:	17.5"



126 HANDLE 126D HANDLE 136 HANDLE 146 HANDLE 156 HANDLE

Part #	210064	210066	210125	210263	210264	210134	210135	210265
Model #	ST2-HB	ST2-P12	186-ZC	126RN-HB	126DRN-HB	136RN-HB	146RN-HB	156RN-HB
Capacity	900 lbs	800 lbs	800 lbs	800 lbs	800 lbs	800 lbs	800 lbs	800 lbs
Wheel: Front	HB	P-12"	Z	HB	HB	HB	HB	HB
Rear	N/A	N/A	4" x 1.25" Poly Swivel Caster	N/A	N/A	N/A	N/A	N/A
Weight	69 lbs	69 lbs	53 lbs	39 lbs	40 lbs	41.5 lbs	42 lbs	38 lbs

- 5 year weld guarantee.
- All joints double welded.
- Structural steel frame construction.
- Ribbed x-braces for added strength.

RK-8 Poly Hub 8" x 2.25"	Z Steel Offset 10" x 2.75" Semi-Pneumatic	HB Cast Iron 8" x 2" Moldon Rubber	P-12 Steel Offset 12" x 4"
050566	150589	150120	108484



5 Year Weld Guarantee



TM-BT

TM4W-HB

Heavy Duty Warehouse Trucks

- Five year weld guarantee.
- Large 10" deep x 16.5" wide x .25" thick tapered nose plate.
- 1" heavy duty structural steel frame.
- Wheel guards standard.
- Dual handle design.
- Kick out four wheel model – TM4W or standard two wheel model.
- 3.5" moldon rubber swivel casters on four wheel kick out trucks.
- New longer 14 ft. belt length on TM4W models.

OVERALL DIMENSIONS			OVERALL DIMENSIONS		
w: 21"	21"	21"	w: 20.5"	20.5"	20.5"
h: 50.5"	50.5"	50.5"	h: 37.25" 4-Wheel / 50.25" 2 Wheel		
d: 22.5"	23.5"	24"	d: 22.5"	22"	22"



210127

210215

SR Economy Hand Truck

- 7.5" x 14" nose plate.
- 16 gauge frame.
- Two Wheel Choices:
10" Pneumatic and
10" Solid Rubber Wheels.

OVERALL DIMENSIONS	
w: 21.5"	21.5"
h: 51"	51"
d: 19"	19"

	Heavy Duty Warehouse Trucks						SR Economy Hand Trucks	
	Part #	210055	210056	210239	210060	210061	210062	210127
Model #	TM-HB	TM-PB	TM-BT	TM4W-HB	TM4W-PB	TM4W-BT	SR Economy-PE	SR Economy - SR
Capacity	900 lbs	700 lbs	1,000 lbs	900 lbs	700 lbs	1,000 lbs bs	500 lbs	500 lbs
Wheel Type	HB	PB	BT	HB	PB	BT	10" Pneumatic	10" Solid Rubber
Caster	N/A	N/A	N/A	3.5"	3.5"	3.5"	N/A	N/A
Weight	54 lbs	49 lbs	75 lbs	78 lbs	75 lbs	98 lbs	26 lbs	28 lbs

HB	PB	BT	PE	SR
Cast Iron 8" x 2"	Steel Offset 10" x 3.5"	Cast Iron 10" x 2.5"	Steel Offset 10" x 3.5"	Poly Offset 10" x 2.5"
Moldon Rubber	Pneumatic	Moldon Rubber	Pneumatic	Solid Rubber
150120	108478	150596	151551	108479

WESCO CYLINDER TRUCKS AND CARTS



LLHPB

LLWPB

Hydraulic Cylinder Lift

- 1-year warranty, parts only.
- WESCO manufactured hydraulic Pedalift Jack, over 35 years of proven quality.
- Easily lifts and transports gas cylinders.
- Swivel casters make maneuvering in tight places easier.
- Two models:
 - Foot operated hydraulic pump.
 - Manual winch with auto-brake feature.
- Maximum cylinder diameter 9.5".
- Platform size: 12" x 20".

OVERALL DIMENSIONS

w:	20"	20"
h:	54"	58"
d:	29.25"	29.25"



210124
4-wheel mode



210123
2-wheel mode



210124
storage mode

Professional Series Cylinder Trucks

- Safety chain helps secure load.
- Easy conversion between all 3 modes using spring-loaded position lock mechanism.
- 8" moldon rubber wheels, 3" swivel casters.
- Holds cylinders up to 9 1/4" in. diameter.
- Noseplate 9" W x 7 1/4" D - single cylinder.
- Noseplate 16 7/8" W x 7 1/4" D - double cylinder.

4-WHEEL OVERALL DIMENSIONS

w:	19"	29"
h:	36.5"	37"
d:	32"	32"

2-WHEEL OVERALL DIMENSIONS

w:	19"	29"
h:	41.75"	42.25"
d:	17.5"	18.5"

STORAGE OVERALL DIMENSIONS

w:	19"	29"
h:	41.75"	42.25"
d:	26"	26"

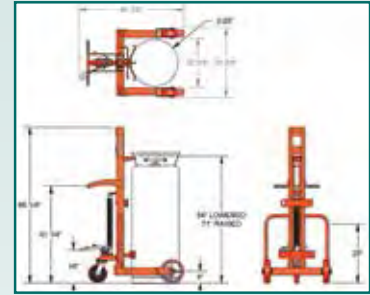

240251



Hydraulic Large Liquid Gas Cylinder Cart

- 1-year warranty, parts only.
- WESCO made hydraulic pump - over 35 years of proven quality.
- Easy transport of large liquid 20" gas cylinders.
- Foot operated hydraulic pump.
- 10" x 2.5" polyurethane wheels.
- 8" polyurethane non-marking swivel caster with swivel locks.
- Ratchet tightening belt to secure cylinder.
- Lifting hook engages cylinder without hand contact - permits hands-free lifting.
- #240250 - without brake.
- #240251 - with brake.

OVERALL DIMENSIONS

w:	29.75"
h:	66.25"
d:	44.75"

Part #	260161	260163	210123	210124	240250	240251
Model #	LLHPB	LLWPB	CC-1	CC-2	HLCC	HLCC-B
Capacity	300 lbs	300 lbs	250 lbs	500 lbs	1,000 lbs	1,000 lbs
Wheel Type	5"	5"	8" Moldon Rubber	8" Moldon Rubber	10" x 2.5" Polyurethane	With Brake 10" x 2.5" Polyurethane
Caster	5" swivel	5" swivel	3"	3"	8" x 2" Swivel	8" x 2" Swivel
Lift Height	40" / Hydraulic	40" / Winch	N/A	N/A	71"	71"
Lowered Height	25"	.25"	N/A	N/A	54"	54"
Weight	165 lbs	152 lbs	40 lbs	50 lbs	130 lbs	140 lbs

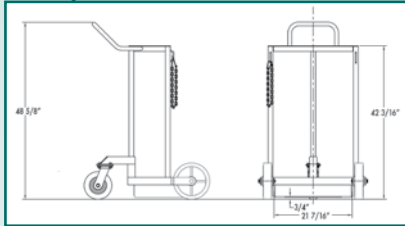

Large Liquid Gas Cylinder Cart

- Easy transport of large liquid 20" gas cylinders.
- Low profile design eases cylinder loading
- Upright design takes up less floor space than traditional lay-back design and provides greater maneuverability in confined space.
- 8" polyurethane-tread, non-marking crowned swivel caster with rolling and swivel lock.
- 10" polyurethane-tread main wheels.
- Heavy duty structural pipe and steel pipe frame.
- Quick-connecting chain helps secure load.

OVERALL DIMENSIONS

w: 30"
h: 48.625"
d: 31"



Large Liquid Gas Cylinder Cart with Power Drive

- 180 degree hinged design allows precision steering in confined spaces.
- Maximum speed with full charge 1.7 mph (2.5 fps) (No Load).
- Speed control is adjustable from 0 to 1.7 mph.
- Automatic Dead Man Brake engages if handle is released.
- Automatic emergency safety switch instantly reverses direction if control comes in contact with the operator or an obstacle.
- Low profile design for ease of cylinder loading
- High Strength Structural Tube Frame for Durability.
- Large 10" x 2.5" Polyurethane Front Wheels for smooth operation.
- Quick-connect Ratchet Strap to secure cylinder.

OVERALL DIMENSIONS

w: 28"
h: 49"
d: 40"



Part # 210131

Model # LCC

Capacity 1,000 lbs

Wheel Type 10" x 2.5" Polyurethane

Caster 8" x 2" Swivel

Lift Height N/A

Lowered Height N/A

Weight 90 lbs

210131-PD

LCC-PD

1,000 lbs

10" x 2.5" Polyurethane

8" x 2" Swivel

N/A

N/A

196 lbs

10" x 2.5"
Polyurethane
Tread Poly-
propylene Hub



053730

Hydraulic
Cylinder Lift
Truck—
see page 57.



Cobra-Lite features:

- All aluminum construction.
- Heavy duty cast 7.5" by 14" or 7.5" by 18" wide nose plate options.
- Quality light weight truck at an economical price.

- Ships KD and boxed or as components (see page 33).
- All 2" wide cross braces for additional strength. Great for advertising label.
- Assembly option available. Add "-A" to Part # below. Example: 220566-A.



Series 410

- Continuous handle.
- 49" overall height.
- Most popular model.
- Available with vinyl dipped handle. See component system on page 33.

OVERALL DIMENSIONS

w: 18"
h: 49"
d: 20



410-T14-R3

Series 420

- High back pin handle.
- Comfortable vinyl hand grip.
- 52" overall height.

OVERALL DIMENSIONS

w: 18"
h: 52"
d: 20



420-T18-P

T14" Nose Part #	220562	220332	220321	220370	220322	220375	220564	220333	220324	220371	220325	220376
Model #	410-T14-BC10	410-T14-R3	410-T14-Z	410-T14-Z2	410-T14-P	410-T14-PE	420-T14-BC10	420-T14-R3	420-T14-Z	420-T14-Z2	420-T14-P	420-T14-PE
Capacity	560 lbs	600 lbs	600 lbs	600 lbs	600 lbs	600 lbs	560 lbs	600 lbs	600 lbs	600 lbs	600 lbs	600 lbs
Wheel Type	BC-10	R3	Z	Z2	P	PE	BC-10	R3	Z	Z2	P	PE
Weight	23 lbs	23 lbs	27.5 lbs	31 lbs	22.5 lbs	21 lbs	23 lbs	19.5 lbs	27.5 lbs	26 lbs	22.5 lbs	21 lbs
T18" Nose Part #	220563	220392	220381	220396	220382	220365	220565	220393	220384	220397	220385	220366
Model #	410-T18-BC10	410-T18-R3	410-T18-Z	410-T18-Z2	410-T18-P	410-T18-PE	420-T18-BC10	420-T18-R3	420-T18-Z	420-T18-Z2	420-T18-P	420-T18-PE
Capacity	560 lbs	600 lbs	600 lbs	600 lbs	600 lbs	600 lbs	560 lbs	600 lbs	600 lbs	600 lbs	600 lbs	600 lbs
Wheel Type	BC-10	R3	Z	Z2	P	PE	BC-10	R3	Z	Z2	P	PE
Weight	23 lbs	20.5 lbs	28.5 lbs	27 lbs	23.5 lbs	22 lbs	23 lbs	20.5 lbs	28.5 lbs	27 lbs	23.5 lbs	22 lbs

Series 450

- Twin handle style with vinyl grips.
- 49" overall height.

OVERALL DIMENSIONS

w: 18"
h: 49"
d: 20



450-T14-R3

Series 470

- High back loop handle.
- 52" overall height.

OVERALL DIMENSIONS

w: 18"
h: 52"
d: 20



470-T14-BC10

T14" Nose Part #	220566	220334	220327	220372	220328	220377	220568	220335	220330	220373	220331	220378
Model #	450-t14-BC10	450-t14-R3	450-t14-Z	450-t14-Z2	450-t14-P	450-t14-PE	470-t14-BC10	470-t14-R3	470-t14-Z	470-t14-Z2	470-t14-P	470-t14-PE
Capacity	560 lbs	600 lbs	600 lbs	600 lbs	600 lbs	600 lbs	560 lbs	600 lbs	600 lbs	600 lbs	600 lbs	600 lbs
Wheel Type	BC-10	R3	Z	Z2	P	PE	BC-10	R3	Z	Z2	P	PE
Weight	23 lbs	20 lbs	28 lbs	26.5 lbs	23 lbs	21.5 lbs	23 lbs	20 lbs	28 lbs	27 lbs	23 lbs	21.5 lbs
T18" Nose Part #	220567	220394	220387	220398	220388	220367	220569	220395	220390	220399	220391	220368
Model #	450-T18-BC10	450-T18-R3	450-T18-Z	450-T18-Z2	450-T18-P	450-T18-PE	470-T18-BC10	470-T18-R3	470-T18-Z	470-T18-Z2	470-T18-P	470-T18-PE
Capacity	560 lbs	600 lbs	600 lbs	600 lbs	600 lbs	600 lbs	560 lbs	600 lbs	600 lbs	600 lbs	600 lbs	600 lbs
Wheel Type	BC-10	R3	Z	Z2	P	PE	BC-10	R3	Z	Z2	P	PE
Weight	23 lbs	21 lbs	29 lbs	27.5 lbs	24 lbs	22.5 lbs	23 lbs	21 lbs	29 lbs	27.5 lbs	24 lbs	22.5 lbs

BC-10	R3	Z	Z2	P	PE	BC-8	CF (Flat Free)
Poly Offset Hub 10" x 2.165" Balloon Cushion	Aluminum Offset 8" x 1.625" Moldon Rubber	Steel Offset 10" x 2.75" Semi-Pneumatic	Poly Offset 10" x 2.75" Solid Rubber	Steel Offset 10" x 3.5" Pneumatic	Steel Offset 10" x 3.5" Pneumatic	Poly Hub 8" x 2.165" Balloon Cushion	Steel Offset 10" x 3" Microcellular
150228	108561	150589	150698	050602	151551	150229	053446



■ When ordering by part # add option part # to truck part #.

Example: 220332,220351

■ When ordering by model #, add option model # to truck model #.

Example: 410-T14-R3-S3K.



Cobra-Lite Folding Nose for Cast and Extruded Noseplates

- | | | | |
|-------------------|------------|----------------------------|------------|
| Factory Installed | | Kit for Field Installation | |
| ■ 20" long | ■ 30" long | ■ 20" long | ■ 30" long |

CAST NOSE PRODUCTS

Part #	054223	054225	220346	220343
Model #	F2F	F3F	F2K	F3K

EXTRUDED NOSE PRODUCTS

Part #	054202	054203	220082	220083
Model #	F2EF	F3EF	F2E	E3E



Cobra-Lite Stairglide Options

Deluxe Cast Aluminum Stairglides

- | | | | |
|---------------------------|------------------------|----------------------------|------------------------|
| Factory Installed | | Kit for Field Installation | |
| ■ Pair without wearstrips | ■ Pair with wearstrips | ■ Pair without wearstrips | ■ Pair with wearstrips |

Part #	054211	054213	220349	220351
Model #	S2F	S3F	S2K	S3K



Steel w/Wearstrip

*With continuous rolling belt (8" wheel only)



Cast Aluminum

Cobra-Lite Stairclimber Options

Stairclimbing Attachments

- | | | | |
|------------------------------|-----------------------|------------------------------|-----------------------|
| Factory Installed | | Kit for Field Installation | |
| ■ Steel pair with wearstrips | ■ Cast aluminum pair* | ■ Steel pair with wearstrips | ■ Cast aluminum pair* |

Part #	054236	054237	220340	220339
Model #	S4F	S5F	S4K	S5K



Top Extensions for 410 & 450 Models

(Special Order: Call factory.)

Installed Height of Extension	Factory Installed				Kit for Field Installation			
	■ 44" high	■ 52" high	■ 60" high	■ 68" high	■ 44" high	■ 52" high	■ 60" high	■ 68" high
Part #	050144	054206	054207	054209	220347	220080	220081	220094
Model #	44UF	52UF	60UF	68UF	44UK	52UK	60UK	68UK

HERE'S HOW TO DESIGN YOUR TRUCK!

- Choose from these Components: Frame, Handle, Noseplate and Wheel.
- Then, choose your Options.
- When ordering by model #, add Option Model # to truck model #.

EXAMPLE 41 + 0 + T18 + R3 + F3 + S4K =
410-T18-R3-F3-S4K



1 CHOOSE A FRAME



2 CHOOSE A HANDLE

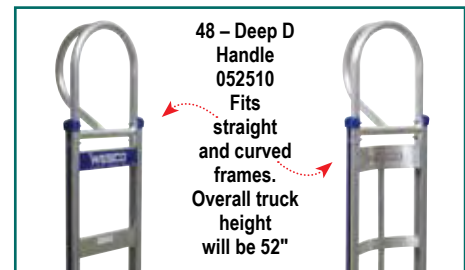
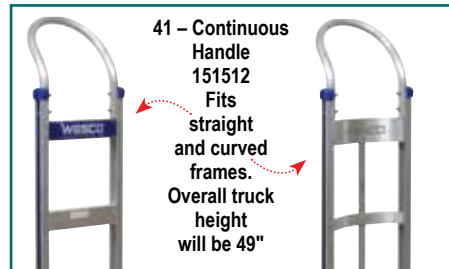

3 CHOOSE A NOSEPLATE



ALUMINUM
T14 (cast)
14" W x 7.5" D
151521

ALUMINUM
E14 (extruded)
14" W x 7.625" D
220287

ALUMINUM
E18 (extruded)
18" W x 7.625" D
220285

ALUMINUM
T18 (cast)
18" W x 7.5" D
151533

ALUMINUM
E918 (extruded)
18" W x 9" D
220461

ALUMINUM
E16 (extruded)
16" W x 12" D
220286

ALUMINUM
EC16 (extruded)
Recessed Heel 16" W x 12" D
220506
For Curved Frame Only

4 CHOOSE A WHEEL



BC-10
Poly Hub
10" x 2.165"
Balloon Cushion
270274

CF (Flat Free)
Steel Offset Hub
10" x 3"
Microcellular Polyurethane.
Will not go flat
220348

P
Steel Offset Hub
10" x 3.5"
Pneumatic Tire
054045

PE
Steel Offset Hub
10" x 3.5"
Pneumatic Tire
054231

PWT
Steel Offset Hub
10" x 3.625"
Pneumatic
Wide Tread Tire
220319

Z
Steel Offset Hub
10" x 2.75"
Semi-Pneumatic
Tire
054047

Z2
Poly Offset Hub
10" x 2.75"
Solid Rubber Tire
054230

BC-8
Poly Hub
8" x 2.165"
Balloon Cushion
270275

R2
Poly Hub
8" x 1.625"
Moldon Rubber
Tire 054046

R3
Aluminum Offset
Hub
8" x 1.625"
Moldon Rubber Tire
054048

Z8
Poly Offset Hub
8" x 2"
Solid Rubber
Tire
220352

5 CHOOSE AN OPTION

EXTENSION OPTIONS



Top extension for 40R, 40B, 41 and 45 handles
44UK – 44" top extension 220347
52UK – 52" top extension 220080
60UK – 60" top extension 220081
68UK – 68" top extension 220094
(Vinyl coated top extensions available – see price list)



Folding nose extension
20" long
F2 – For Cast Noses 220346
F2E – For Extruded Noses 220082
30" long
F3 – For Cast Noses 220343
F3E – For Extruded Noses 220083

STAIR GLIDE & CLIMBER OPTIONS



S2K:
*Deluxe cast aluminum stair glides without wearstrip 220349
S3K: # 220351 with wearstrip



S4K
Steel stair glides with wearstrips 220340
Field Install Kit
S4F #054236
Factory Install



S5K
Continuous belt stair climbers 220339
(For 8" wheel only)
Field Install Kit
S5F #054237
Factory Install

STRAP



CS
Center strap option 054062

WESCO COBRA ALUMINUM CONVERTIBLE TRUCKS

Cobra Jr. and Sr. features:

- 18" wide noseplate for large loads.
- Smooth and easy transition from the 2 to 4 wheeled position.
- Non-marking 5" x 1.25" swivel casters.
- Add B to end of part number for blue coated handle option.

- 8 rivets per cross brace. Welded release pedal.
- Custom advertising side strips available – contact dealer for details.
- 2" wide cross braces for added strength and advertising labels.



Higher Capacity Convertible Trucks - 1,200 lbs. 2 Year Frame Warranty

Cobra Jr.

- 2 Year Frame Warranty.
- Dual hand grips for improved control.
- 3 frame cross braces.
- 12 inch x 38 inch frame bed.



220291



2 Wheel OVERALL DIMENSIONS	4 Wheel OVERALL DIMENSIONS
w: 22" h: 51.75" d: 19"	w: 46.5" h: 40" d: 19"

Cobra Sr.

- 2 Year Frame Warranty.
- Continuous handle allows multiple ways to control load.
- 4 frame cross braces.
- 12 inch x 50.75 inch frame bed.



220290



2 Wheel OVERALL DIMENSIONS	4 Wheel OVERALL DIMENSIONS
w: 22" h: 61.75" d: 19"	w: 55.625" h: 45.5" d: 19"

	18"W x 7.5"D	18"W x 7.5"D	18"W x 7.5"D	18"W x 7.5"D	18"W x 7.5"D	18"W x 7.5"D	18"W x 7.5"D	18"W x 7.5"D	18"W x 7.5"D	18"W x 7.5"D
T18 Nose Part #	220293	220291	220295	220297	220622	220292	220290	220294	220296	220618
Model #	CBR-JR-T18-PWT	CBR-JR-T18-PE	CBR-JR-T18-Z	CBR-JR-T18-Z2	CBR-JR-T18-CF	CBR-SR-T18-PWT	CBR-SR-T18-PE	CBR-SR-T18-Z	CBR-SR-T18-Z2	CBR-SR-T18-CF
E18 Nose Part #	220482	220494	220486	220490	220515	220484	220496	220488	220492	220516
Model #	CBR-JR-E18-PWT	CBR-JR-E18-PE	CBR-JR-E18-Z	CBR-JR-E18-Z2	CBR-JR-E18-CF	CBR-SR-E18-PWT	CBR-SR-E18-PE	CBR-SR-E18-Z	CBR-SR-E18-Z2	CBR-SR-E18-CF
E16 Nose Part #	220483	220495	220487	220491	220666	220485	220497	220489	220493	220667
Model #	CBR-JR-E16-PWT	CBR-JR-E16-PE	CBR-JR-E16-Z	CBR-JR-E16-Z2	CBR-JR-E16-CF	CBR-SR-E16-PWT	CBR-SR-E16-PE	CBR-SR-E16-Z	CBR-SR-E16-Z2	CBR-SR-E16-CF
Capacity 2 Wheel	600 lbs	600 lbs	600 lbs	600 lbs	560 lbs	600 lbs	600 lbs	600 lbs	600 lbs	560 lbs
4 Wheel	1,200 lbs	1,200 lbs	1,200 lbs	1,200 lbs	1,160 lbs	1,200 lbs	1,200 lbs	1,200 lbs	1,200 lbs	1,160 lbs
Frame Bed	12" x 38"	12" x 38"	12" x 38"	12" x 38"	12" x 38"	12" x 50.75"	12" x 50.75"	12" x 50.75"	12" x 50.75"	12" x 50.75"
Wheel	PWT	PE	Z	Z2	CF	PWT	PE	Z	Z2	CF
Weight	39 lbs	37.5 lbs	43.5 lbs	42.5 lbs	41 lbs	42.5 lbs	41 lbs	47 lbs	46 lbs	41 lbs

Cobra Platform Deck Option

- Platform Deck: Slip resistant diamond pattern surface for both cast and extruded noseplates.



Part #	220289	220288	220514	220318
Model #	JRD	SRD	JRDE	SRDE
For Use With	Jr/Cast Noseplate	Sr/Cast Noseplate	Jr/Extruded Noseplate	Sr/Extruded Noseplate
Length	42"	55"	42"	55"
Weight	8 lbs	10 lbs	7 lbs	9 lbs

Cobra Folding Nose Option

- Coated handle.

Kit for Field Installation

- 20" for T-18 Noseplates
- 20" for E-18 & E-16 Noseplates
- 30" for T-18 Noseplates
- 30" for E-18 & E-16 Noseplates

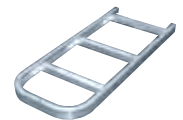

Part #	220346	220082	220343	220083
Model #	F2	F2E	F3	F3E

Factory Installed				
Part #	054223	054202	054225	054203
Model #	F2F	F2EF	F3F	F3EF

Additional choice not listed above.

PWT (Wide Tread)	PE	Z	Z2	CF (Flat Free)	BC-10
Steel Offset 10" x 3.5" Pneumatic	Steel Offset 10" x 3.5" Pneumatic	Steel Offset 10" x 2.75" Semi-Pneumatic	Poly Offset 10" x 2.75" Solid Rubber	Steel Offset 10" x 3" Microcellular	Poly Hub 10" x 2.165" Balloon Cushion
151507	151551	150589	150698	053446	150228



Spartan Jr.

219998



Spartan Sr.

220001

Spartan Economy Aluminum 2 in 1 Trucks

- Value-priced truck.
- Two sizes - Jr. and Sr.
- Sturdy, lightweight aluminum frame.
- 18" wide x 7.5" deep noseplate for large loads.
- Wheels: PE 10" pneumatic or SR 10" solid rubber.
- Non-marking 5" x 1.25" swivel casters.
- Pedal release allows easy conversion from 2-wheel to 4-wheel position.
- Extra strength noseplate cast from special aluminum alloy.**
- Ships KD and boxed.
- Assembly option available. Add "-A" to Part # below. Example: 220000-A.

2 Wheel	4 Wheel	4 Wheel	2 Wheel	4 Wheel	4 Wheel
OVERALL DIMENSIONS			OVERALL DIMENSIONS		
w: 22"	22"	22"	w: 22"	22"	22"
h: 52"	40"	40"	h: 61.5"	45.5"	45.5"
d: 19"	19"	19"	d: 19"	19"	19"

Part #	220000	219998	220145	220001	219999	220144
Model #	SPTN-JR-T18-PE	SPTN-JR-T18-SR	SPTN-JR-T18-CF	SPTN-SR-T18-PE	SPTN-SR-T18-SR	SPTN-SR-T18-CF
Capacity						
2 Wheel	500 lbs	500 lbs	500 lbs	500 lbs	500 lbs	500 lbs
4 Wheel	1,000 lbs	1,000 lbs	1,000 lbs	1,000 lbs	1,000 lbs	1,000 lbs
Description	12" x 38" Bed	12" x 38" Bed	12" x 38" Bed	12" x 51" Bed	12" x 51" Bed	12" x 51" Bed
Wheel	PE	SR	CF	PE	SR	CF
Caster	5" x 1.25"	5" x 1.25"	5" x 1.25"	5" x 1.25"	5" x 1.25"	5" x 1.25"
Weight	44 lbs	54 lbs	44 lbs	46.3 lbs	58 lbs	48 lbs

Spartan and CobraPRO Options



Platform Deck*

Part #	Spartan Jr. Models	CobraPRO Jr. Models	Spartan Sr. and CobraPRO Sr. Models	30" Folding Nose	
				Field Install	Factory Install
220800	JRSD	JRD	SRD	220343	054225
Model #	JRSD	JRD	SRD	F3	F3F
Length	42"	42"	55"	30"	30"
Weight	8 lbs	8 lbs	10 lbs	5 lbs	2 lbs

PE Steel Offset 10" x 3.5" Pneumatic	SR Poly Offset 10" x 2.5" Solid Rubber	CF (Flat Free) Steel Offset 10" x 3" Microcellular	PWT Steel Offset 10" x 3.625" Pneumatic
151551	108479	053446	151507



BATTERY POWERED COBRAPRO

CobraPRO Jr. and Sr. have 950 lb. capacity in 4-wheel mode and 600 lb. capacity in 2-wheel mode on standard 17.5° ramp.



220653



220656

Shown with optional 30" folding nose #220343



CobraPRO Jr.

2 Year Frame Warranty.

- Dual hand grips for improved control.
- Variable speed fingertip control. Forward and reverse.
- 3 frame cross braces.
- Battery and charger included.

2 Wheel 4 Wheel OVERALL DIMENSIONS

w: 22"	46.5"
h: 51.75"	40"
d: 19"	19"

220653
PCBR-JR-T18-PWT

600 lbs
1,200 lbs

12" x 38"

10" PWT Pneumatic

5" x 1.25"

109 lbs

CobraPRO Sr.

2 Year Frame Warranty.

- Continuous handle allows multiple ways to control load.
- Variable speed fingertip control. Forward and reverse.
- 4 frame cross braces.
- Battery and charger included.

2 Wheel 4 Wheel OVERALL DIMENSIONS

w: 22"	55.625"
h: 61.75"	45.5"
d: 19"	19"

220656
PCBR-SR-T18-PWT

600 lbs
1,200 lbs

12" x 50.75"

10" PWT Pneumatic

5" x 1.25"

112.5 lbs

Spare Battery Module

Part #220655

- Plugs directly into drive unit.
- No need to attach cables.
- Spare battery module includes 2 batteries and case.
- 25 lbs.

HAND TRUCKS

COBRA



220615

Mini Cobra

- 2 Year Frame Warranty.
- Unique design allows user to fold nose for storage.
- 4" x 1.25" non-marking swivel casters.
- 8.25" x 32.25" frame bed.
- Folding noseplate 7" D x 14" W.
- 8" x 2.25" pneumatic wheels.

	2 Wheel	4 Wheel
OVERALL DIMENSIONS		
w:	15"	15"
h:	44"	32.5"
d:	16"	16"



270391

1



2



3

Spartan III

- Value priced truck.
- Aluminum construction.
- Quickly converts into 3 positions:
 1. Vertical 2-Wheel
 2. 45° 4-Wheel
 3. Platform Wheel.
- 18" x 7.5" cast aluminum noseplate.
- 7.5" W x 27" L recessed folding nose extension.
- Handle height 48".
- 10" full pneumatic wheel.
- 5" x 1.25" swivel casters.
- Ships KD/boxed.

	2 Wheel	4 Wheel
OVERALL DIMENSIONS		
w:	21.5"	*
h:	52"	42.25"
d:	19"	19"

Part #	220615	270391
Model #	CBR-FBL	SPTN-III
Capacity		45° / 4 Wheel - 500 lbs
2 Wheel	300 lbs	2 Wheel - 500 lbs
4 Wheel	500 lbs	4 Wheel - 750 lbs
Frame Bed	8.25" x 32.25"	12" X 51"
Wheel	8" Pneumatic	PE
Caster	4" Jarvis Advantage	5" x 1.25" Swivel Casters
Weight	28 lbs	45 lbs

* Platform position 60". 45° position 49".



WESCO® POWER LIFTKAR HD STAIRCLIMBING TRUCKS

See the **LIFTKAR** video on our website! www.wescomfg.com



UNI
Part #274100 with optional fold-out wheel carriage - #274102 and #274103 snap-on toe plate



Optional 274103 snap-on toe plate with 4 dual swivel casters



FOLD
Part #274101



EXTENDED FOLD
Part #274238
Extended Height HD
Complete with fold-out carriage.

UNI
Part #274100 with optional snap-on toe plate - #274103.

Power LiftKar HD: 725 lb. high capacity models

Three Models

Uni – straight frame – accepts #274102 fold-out wheel carriage for 4-wheel support.

Fold – upper handle angle can be adjusted. Best for copiers, safes, heavy motors or any short and heavy load which would require the user to pull the load back to a very low position for proper balance. The adjustable angle position on the Fold model allows the user to stand upright when using the truck at a very low angle.

Extended Fold – Same advantages as **Fold** but with an extra 7" in height and fold-out wheel carriage.

■ Innovative edge-of-step braking system – automatically applies brake when wheels are at edge of step. Helps prevent loss of load control caused by accidental rolling down steps.

■ Brake can be shut off for use on level ground – prevents unwanted braking when moving over ground with an uneven surface.

■ Two operating modes: single step (ascend or descend button must be pressed after each step – ideal for maximum control), or continuous climb.

■ 24v quick-change battery pack – sealed maintenance-free battery.

■ Battery, charger and 137" x 2" cargo belt included.

■ 21" W x 7.25" D noseplate. Additional sizes available, contact Wesco Customer Service.

■ Two climbing speeds: 6 steps/min. or 10 steps/min.

■ Average number of steps with fully charged battery:

440 lbs. of cargo - 220 steps

550 lbs. of cargo - 190 steps

725 lbs. of cargo - 120 steps.

■ Maximum stair height 8.25".

■ 1 year warranty on parts against defects in materials and workmanship.

■ 6 month warranty on battery.

Power LiftKar Options

■ **Part # 274103 - Snap-on toe plate** equipped with 4 dual casters.

Provides additional cargo space and the ability to move loads without tilting truck. Especially useful in confined areas. 21" W x 14" D.

■ **Part # 274102 - Fold-out rear wheel carriage** for Universal model only - slides easily into position to provide 4-wheel support.

■ **Part # 274116 - Extra quick-change battery pack.**

■ **Part # 274181 - In-transit 12 Volt DC auto charger.**

■ **Part # 274185 - Standard 110 Volt battery charger.**



OVERALL DIMENSIONS

w: 22"
h: 63"
d: 19"

OVERALL DIMENSIONS

w: 22"
h: 47" - folded / 63" unfolded
d: 19"

OVERALL DIMENSIONS

w: 22"
h: 53.5" - folded / 70" unfolded
d: 21.3"

HAND TRUCKS

Part #	274100	274101	274238
Model	Universal	Fold	Extended Height Fold
Battery	Single	Single	Single
Capacity	725 lbs	725 lbs	725 lbs
Height	63" straight frame	47" folded	70" straight frame
Belt	2 piece with clasp - 137" x 2"	2 piece with clasp - 137" x 2"	2 piece with clasp - 137" x 2"
Weight	96 lbs	97 lbs	105 lbs

4 EASY STEPS TO CONFIGURE YOUR LIFTKAR!

LIFTKAR® SAL

- Dual speed control on all models to fit your application.
- Quick-change battery and charger included.
- Pivoting and fixed handle configurations available to handle a wide variety of cargo.
- Choose from the long list of options to maximize the utility of your Liftkar.
- 240, 300 and 375 lb. capacity models.
- Climbs up to 48 steps per minute.
- All models include charger and battery.
- 1 year warranty on parts against defects in materials and workmanship.
- 6 month warranty on battery.

See the **LIFTKAR** video on our website!
www.wescomfg.com

1 Choose your frame.

Ergo

The ergo handle is the most popular all-purpose model with 3-handle gripping points providing proper balance for a variety of loads.

(Recommended maximum cargo height - 58".)

(Shown with "G" Toe Plate.)



2 Choose your capacity and tire type.

Base Model - 240 lb capacity
 Base Model - 300 lb capacity
 Base Model - 375 lb capacity

See page 37 for 725 lb capacity HD models.

Maximum number of steps with fully charged battery - all models:
 200 - 300 steps - ascending
 400 - 600 steps - descending

	Pneumatic Tire Part Number	Microcellular Tire Part Number	Capacity	Max. Steps per min	W x H	Weight
240 lb Capacity Models - includes battery and charger						
Ergo	274140	274152	240 lbs	48	18.5" x 63"	42.7 lbs
Fold	274141	274153	240 lbs	48	18" x 61" unfolded/ 39.5 folded	42.2 lbs
Uni	274142	274154	240 lbs	48	17.5" x 59"	41.8 lbs
Fold-L	274143	274155	240 lbs	48	19" x 64.5" unfolded/ 51 folded	44.9 lbs
300 lb Capacity Models - includes battery and charger						
Ergo	274144	274156	300 lbs	35	18.5" x 63"	42.7 lbs
Fold	274145	274157	300 lbs	35	18" x 61" unfolded/ 39.5 folded	42.2 lbs
Uni	274146	274158	300 lbs	35	17.5" x 59"	41.8 lbs
Fold-L	274147	274159	300 lbs	35	19" x 64.5" unfolded/ 51 folded	44.9 lbs
375 lb Capacity Models - includes battery and charger						
Ergo	274148	274160	375 lbs	29	18.5" x 63"	42.7 lbs
Fold	274149	274161	375 lbs	29	18" x 61" unfolded/ 39.5 folded	42.2 lbs
Uni	274150	274162	375 lbs	29	17.5" x 59"	41.8 lbs
Fold-L	274151	274163	375 lbs	29	19" x 64.5" unfolded/ 51 folded	44.9 lbs

3 Choose toe plate.

Add Toe Plate Part Number to Base Model Number.

	Toe Plate Part Number	Grooved or Smooth*	W x D	Weight
G	274164	Grooved	16.5" x 13.4"	4.6 lbs
GS	274165	Grooved	18.8" x 9.4"	4.1 lbs
LH	274166	Smooth	18.45" x 10.9"	3.7 lbs
GS-NG	274167	Smooth	18.74" x 9.4"	4.1 lbs
DS-NG	274168	Smooth	17.7" x 7.5"	4.1 lbs
WL	274169	Grooved	14" x 7"	2.2 lbs
XWL	274170	Grooved	23.25" x 7"	3.9 lbs

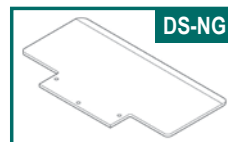
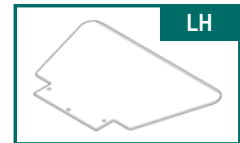

Uni

Ideal for tall, easily balanced loads. 2-handle gripping points. (Shown with "G" Toe Plate.)



Fold

This model allows user to place handle in optimum position. Ideal for short, heavy loads that require truck to be tilted to an extreme angle for proper balance. (Shown with "G" Toe Plate.)



Fold L

Similar to fold but has a longer frame and shorter folding handle. This makes it ideal for loads that require less tilt for proper balance than the Fold provides. (Shown with "G" Toe Plate.)



4 Choose accessories.

	Part Number	Weight
Keg Hook	274174	1.2 lbs
Center Strap w/ extra crossbar - Uni and Ergo only	274175	1.1 lbs
Center Bar provides flat surface - Uni and Ergo only	274176	1.8 lbs
55" x 1" Cargo Strap w/buckle	274177	1.1 lbs
107" x 1" Cargo Strap w/buckle	274178	1.1 lbs
137" x 2" Cargo Strap w/buckle	274199	1.5 lbs
Panel / Window / Door Holder	274179	35.6 lbs
Extension Wings (Uni, Ergo, Fold-L)	274180	3.3 lbs
Cigarette Lighter Charger	274181	0.9 lbs
Battery Retainer	274104	1.0 lbs
Lifting System (Uni, Ergo, Fold-L)	274237	51 lbs
Extra Battery	274116	9.5 lbs

For detailed information on accessories, contact Wesco®.



Part #274174
Keg Hook



Part #274199
2" Strap



Part #274177
or #274178 - 1" Strap



Part #274180
Extension Wings



Part #274237 Lift System in use
Not for use with toe plates WL or XWL.
Capacity: 265 lbs. Lift height: 35.5"



Part #274175
Center Strap



Part #274179 in use
Door/Window Holder



Part #274176
Center Bar

WESCO® STAIRKING APPLIANCE TRUCK & OPTIONS



230051



DC-66



StairKing Battery Powered Stair Climbing Appliance Truck

■ U.S. Pat. No. 7,137,464

- Welded aluminum construction.
- 1/2 Horsepower, 50 amp, high torque motor runs cooler under load.
- Industrial grade gear box transmits steady power and is preferable to other drive designs.
- Large 2" diameter, polyurethane lifting feet provide more secure stair gripping.
- Auto rewind ratchet works first to take the slack out of the cargo belt, and then provides a ratchet crank to securely tighten the load.
- Noseplate measures 24" by 4" deep. Welded lightweight frame and noseplate.
- 30" from noseplate to center of belt.
- Sealed maintenance-free battery. AC charger and circuit breaker included.
- 6" moldon rubber wheels.

■ Average number of steps with fully charged battery:

LOAD	STEPS
225 lbs	160
450 lbs	135
850 lbs	70

OVERALL DIMENSIONS

w: 24"
h: 66" or 72"
d: 12"

StairKing Battery Powered Stair Climbing Appliance Truck

Cargo Belt Tightening Ratchet

Auto-Rewind Assembly

Heavy Duty Motor and Geared Transmission

Rechargeable Battery

Continuous Tread Stair Climbers

2" Diameter Lifting Rollers on Sprocketed Drive Chains

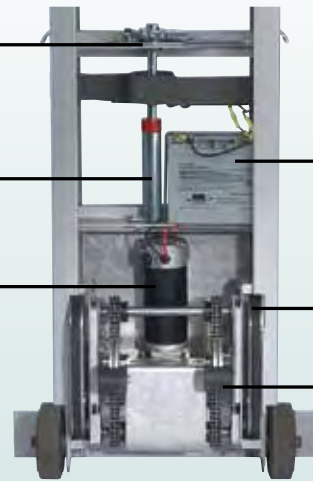

STAIRKING OPTIONS



MSWK Superwheel Option



- Superwheel attachment installs in seconds.
- Equipped with 10" x 4" full pneumatic tires. Provides 4 wheel support and eases transport over rough surfaces.

OVERALL DIMENSIONS

w: 11.5"
h: 4.5"
d: 20.5"



NE-28 Steel Nose Extension Option



- Toe plate extension. Easily clips on to standard toe plate and provides 12" deep x 28" wide cargo surface.

OVERALL DIMENSIONS

w: 28"
h: 4"
d: 12"



SP-20 Platform Option slips onto WLF forks

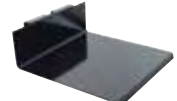

- Platform attachment. Slides in place over winch lift forks to provide a 20" x 20" lifting platform.

OVERALL DIMENSIONS

w: 20"
h: 7"
d: 20"

Part #	230051	230052
Model	DC-66	DC-72
Capacity	850 lbs	850 lbs
Ratchet	Auto rewind	Auto rewind
Belt	2 piece w/clasp	2 piece w/clasp
Height	66" tall frame	72" tall frame
Weight	101 lbs	102 lbs

Part #	270076	230055	260160
Model #	MSWK	NE-28	SP-20
Capacity	N/A	850 lbs	800 lbs
Description	Superwheel Option	Steel Nose Extension	Steel Slip on Platform
Weight	19 lbs	18 lbs	20 lbs



SINCE 1948

STAIRING OPTIONS

Accessory Winch Lift for StairKing



DC-66 with WLF Option

WLF Winch Lift Option

- Optional aluminum winch lift attachment has 800 lb capacity.
- 3-1/2" swivel casters for 4 wheel support and mobility.
- Winch equipped with autobraking system.
- 18" forks, adjustable width 8.5" to 19" outside dimension.
- 57.25" lift height.
- Factory or field installation.

OVERALL DIMENSIONS

w: 25"
h: 70"
d: 30"



Battery Charger Cord

- Charge battery while driving between stops.
- Plugs into cigarette lighter.
- Cable length 20'.
- Standard A.C. charger is included with truck purchase.



KOW Kick-out Wheel

- Kick-Out 3.5" casters for four wheel stability.

OVERALL DIMENSIONS

w: 25"
h: 70"
d: 30"

Part #	230053	230059	230060
Model #	WLF	KOW	BC
Capacity	800 lbs	850 lbs	N/A
Description	Aluminum Winch Lift Attachment	Kick-out Wheel	Cigarette Lighter Charger
Weight	67 lbs	14 lbs	2 lbs



Economical Aluminum Appliance and Vending Trucks

- **Exclusive Wesco ratchet design.**
- Lightweight aluminum frame with auto rewind ratchet.
- Model AAP-612 has double ratchet design for greater cargo security.
- Model AVT-61 has four wheel swing-out design to support heavy loads and help reduce the strain of balancing the cargo over long distances.
- 6" x 2" moldon rubber wheel, poly hub.
- Noseplate: 24" W x 5" D.

	OVERALL DIMENSIONS		
w: 24"	24"	24"	24"
h: 61"	61"	61"	61"
d: 12"	12"	12"	12"

Part #	272410	272411	272412
Model #	AAP-61	AAP-612	AVT-61
Capacity	550 lbs	550 lbs	550 lbs
Ratchet	Auto rewind	Auto rewind	Auto rewind
Belt	2 piece w/clasp	double 2 piece w/clasp	2 piece w/clasp
Wheel	6" x 2"	6" x 2"	6" x 2" (2" x 1" caster)
Weight	40 lbs	43 lbs	50 lbs

HAND TRUCKS

Features:

- **Welded frame and handles for maximum strength.**
- **Non-marking grey vinyl on all contact surfaces securely mounted to truck.**
- **2" wide heavy duty web belt.**



Improved kick-out design allows operator to kick-out wheels with both hands on the truck.



WRV-66



WRC

Wesco Steel Vending Machine Trucks

- Retractable moldon rubber casters (3.5" diameter) help support load.
- Heavy duty 8" cast iron center moldon rubber wheels with roller bearings - #150120.
- Available with "Auto-Rewind" or "Manual" belt tightening systems.
- 28.5" from noseplate to center of belt.
- 60" and 66" frame - 3/4"-14 Ga. steel tube.
- 72" frame - 1"-14 Ga. steel tube.
- Noseplate 24" wide x 5" deep.

OVERALL DIMENSIONS

w: 24"
h: 60" or 66" or 72"
d: 14.5"

Wesco Steel Appliance Trucks

- All joints double welded for maximum durability.
- Rugged tubular steel construction.
- Available with "Auto-Rewind" or "Manual" belt tightening systems.
- Available with 6" x 2" wheels with 5/8" precision ball bearings.
- 26.5" from noseplate to center of belt.
- Noseplate 24" wide x 5" deep.

OVERALL DIMENSIONS

w: 24"
h: 59"
d: 10"

Part #	230035	230017	230036	230018	230037	230019	230010	230028
Model #	WRV-60-EC	WRV-60	WRV-66-EC	WRV-66	WRV-72-EC	WRV-72	WRC	WRC-EC
Capacity	1,200 lbs	1,200 lbs	1,200 lbs	1,200 lbs	1,200 lbs	1,200 lbs	750 lbs	750 lbs
Ratchet	Manual	Auto rewind	Manual	Auto rewind	Manual	Auto rewind	Auto rewind	Manual
Belt	1 piece	2 piece clasp	1 piece	2 piece clasp	1 piece	2 piece clasp	2 piece clasp	1 piece
Wheel	HB	HB	HB	HB	HB	HB	A	A
Height	60"	60"	66"	66"	72"	72"	59"	59"
Weight	80 lbs	80 lbs	86 lbs	86 lbs	95 lbs	95 lbs	52 lbs	52 lbs

Super Wheel

Part #270075 Model # SSWK

- 10" pneumatic rear wheels .
- Quick and easy turnbuckle mounting system.
- Converts a 2 wheel truck into a 4 wheel truck.

Note: Cannot be used on 72" WRV-72 Models.

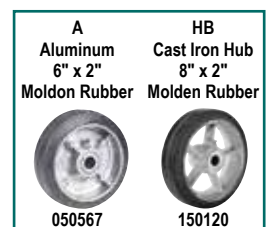



230074



230076

A Wesco Unique Design - Swivel casters may be deployed for easy steering and 4-wheel support



230020

Heavy Duty Vending Trucks

- **WHEEL LOCK FEATURE STANDARD:** Front wheels have wheel locks to allow truck to be placed in upright position without the danger of the truck rolling away from operator. Wheel lock is activated by a conveniently located lever at top of truck.
- In transport position load rests on (2) 10" poly hub moldon rubber wheels and (2) 5" poly hub moldon rubber front wheels.
- Rear main wheel design allows truck to be tilted back to clear doorways. Especially useful with tall vending machines or other tall cargo.
- Available in 72" and 78" heights.
- 2 webbed cargo belts with ratchet tighteners for maximum load security.
- Constructed of heavy duty 1" diameter steel tubing.
- Noseplate - 5" D x 24" W x .25" thick.
- Tilts back at 49° angle.

OVERALL DIMENSIONS

w: 27"	27"
h: 72"	78"
d: 17"	17"

Heavy Duty Auto-Rewind Appliance Truck with Swivel Casters

- Truck can be used in 2-wheel or 4-wheel mode.
- Dynamic lever activated fulcrum system – fulcrum point changes as truck is tilted to decrease break-over effort.
- Swivel caster carriage kickout for four wheel support, lever release.
- 10" poly hub main wheels, 6" rear swivel casters.
- Available in 72" and 78" heights.
- 2 webbed cargo belts with ratchet tighteners for maximum load security.
- Constructed of heavy duty 1" diameter steel tubing.
- Noseplate - 5" D x 24" W x .25" thick.

OVERALL DIMENSIONS

w: 27"	27"
h: 72"	78"
d: 16"	16"

Wesco Steel Vending Truck

- Dual handle control.
- 12" pneumatic wheels for rough terrain - #108484.
- Welded steel frame.
- One piece belt.
- 47" from noseplate to center of belt.
- 55" height.
- Noseplate - 4.94" D x 25" W x .25" thick.

OVERALL DIMENSIONS

w: 28.5"
h: 55"
d: 20"

Part #	230074	230075	230076	230077	230020
Model #	HDSV-72	HDSV-78	WRV-MAX-72	WRV-MAX-78	L-1
Capacity	1,800 lbs	1,800 lbs	1,800 lbs	1,800 lbs	700 lbs
Ratchet	Auto Rewind	Auto Rewind	Auto rewind	Auto rewind	N/A
Belt	2 piece w/clasp	2 piece w/clasp	2 piece w/clasp	2 piece w/clasp	1 piece clasp
Wheel	10" x 2.5" Poly	10" x 2.5" Poly	10" x 2.5" Poly	10" x 2.5" Poly	P-12
Noseplate	24"W x5"D	24"W x5"D	24"W x5"D	24"W x5"D	25"W x 5.2"D
Weight	126 lbs	129 lbs	120 lbs	130 lbs	62 lbs



WESCO DELUXE PALLET TRUCKS

ADJUSTABLE FORK WIDTHS
Two sizes of width, 16" - 20" and 21" - 27". Just loosen and reset front and rear adjusting bolts. **A Wesco exclusive. One truck to do the work of two!**



27" Fork Width Setting

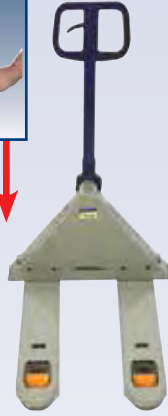

21" Fork Width Setting

272744

Deluxe Adjustable Fork Model

- **5 year pump warranty.**
- **US Patent No. 6,808,357.**
- Available in 16" or 21" widths.
- 7" non-marking moldon polyurethane steering wheel.
- 3" non-marking moldon polyurethane load wheels.
- 7.75" raised height; 3" lowered height.
- 6" wide gauge forks.
- 200° steering radius.

Deluxe Models feature 5 year pump warranty and 5,500 lb. capacity plus:

- Pump overload bypass.
- Rubber coated handle.
- Adjustable fork tie rods.
- Exit rollers
- 200° steering.
- Tapered fork tips.
- 8 gauge 6" wide reinforced forks.
- Non-marking.



Deluxe Quick Lift Model

- **5 year pump warranty.**
- **US Patent No. 9,102, 346.**
- Fastest/quickest lift on the market.
- Just step on the pedal. **No Pumping.** Lifts to 4.5".
- 7" non-marking moldon polyurethane steering wheel.
- 3" non-marking moldon polyurethane load wheels.
- All the same features and dimensions as Standard Deluxe models.
- Normal pump operation when load exceeds 300 lbs.
- 200° steering radius.

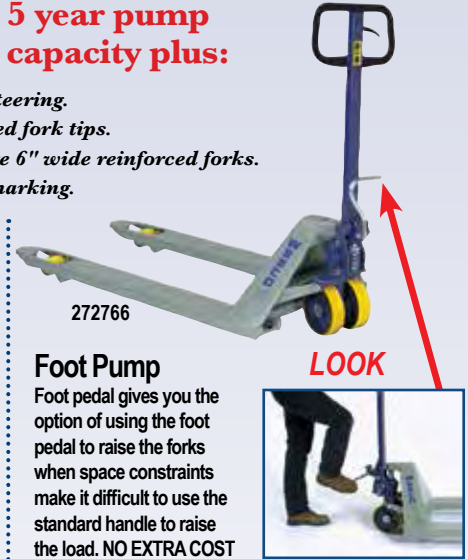

272766

Foot Pump

Foot pedal gives you the option of using the foot pedal to raise the forks when space constraints make it difficult to use the standard handle to raise the load. **NO EXTRA COST**



Deluxe Foot Pump Model

- **5 year pump warranty.**
- 7" non-marking moldon polyurethane steering wheel.
- 3" non-marking moldon polyurethane load wheels.
- All the same features and dimensions as Standard Deluxe Model 272748.
- 6" wide gauge forks.
- 200° steering radius.

Part #	272744	272747	272746	272861	272766
Capacity	5,500 lbs	5,500 lbs	5,500 lbs.	5,500 lbs /300 lb Q.L	5,500 lbs
W-1 x L-1	21"-27" x 48"	16" -20" x 36"	16" -20" x 48"	27" x 48"	27" x 48"
W-2	6"	6"	6"	6"	6"
L-2	61"	51"	61"	63"	63"
WHL-1 / WHL-2	7" / 3"	7" / 3"	7" / 3"	7" / 3"	8" / 3"
H-1 / H-2 / H-3	47" / 3" / 7.75"	47" / 3" / 7.75"	47" / 3" / 7.75"	48" / 3" / 8"	48" / 3" / 8"
Weight	180 lbs	147.5 lbs	157 lbs	166 lbs	170 lbs

Deluxe Lowboy Models

- **5 year pump warranty.**
- **2.125" lowered height.**
- 6" non-marking moldon polyurethane steering wheel.
- 2" steel load wheels.
- 6.25" raised height.
- 6" wide gauge forks.
- 200° steering radius.



272765

Standard Deluxe Models

- **5 year pump warranty.**
- 8" non-marking moldon polyurethane steering wheel.
- 3" non-marking moldon polyurethane load wheels.
- 8" raised height.
- 3" lowered height.
- 6" wide forks.
- 200° steering radius.



272748

Part #	272760	272761	272762	272765	272136	272142	272148	272736	272742	272748
Capacity	5,500 lbs	5,500 lbs	5,500 lbs	5,500 lbs	5,500 lbs	5,500 lbs	5,500 lbs	5,500 lbs	5,500 lbs	5,500 lb
W-1 x L-1	21" x 36"	21" x 42"	21" x 48"	27" x 48"	21" x 36"	21" x 42"	21" x 48"	27" x 36"	27" x 42"	27" x 48"
W-2	6"	6"	6"	6"	6"	6"	6"	6"	6"	6"
L-2	51"	57"	63"	63"	51"	57"	63"	51"	57"	63"
WHL-1 / WHL-2	6" / 2"	6" / 2"	6" / 2"	6" / 2"	8" / 3"	8" / 3"	8" / 3"	8" / 3"	8" / 3"	8" / 3"
H-1 / H-2 / H-3	46.5" / 2.125" / 6.25"	46.5" / 2.125" / 6.25"	46.5" / 2.125" / 6.25"	46.5" / 2.125" / 6.25"	48" / 3" / 8"	48" / 3" / 8"	48" / 3" / 8"	48" / 3" / 8"	48" / 3" / 8"	48" / 3" / 8"
Weight	134 lbs	143 lbs	148 lbs	157 lbs	143 lbs	152 lbs	157 lbs	151 lbs	161 lbs	166 lbs

SEE PAGE 45 FOR SCHEMATIC DRAWING.

REFERENCE SCHEMATIC FOR PAGES 44 & 45

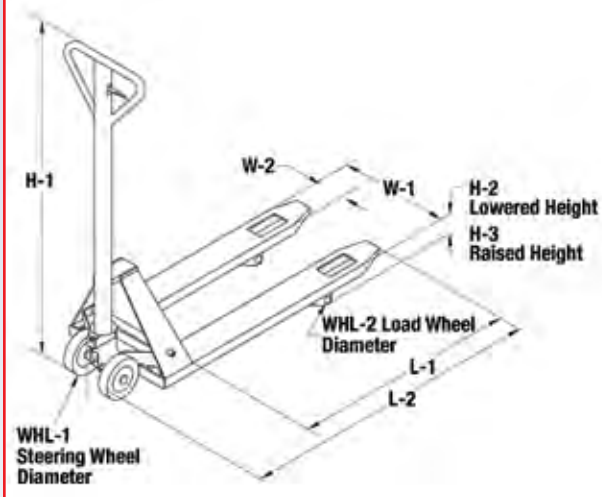

**Pallet Truck
Chock:
High
Visibility
Yellow**



**FOR MORE PALLET TRUCK OPTIONS
(Chocks and Guards) see page 54.**



272660

CPI Pallet Truck

- **2 year pump warranty.**
- **4 mm thick forks.**
- Adjustable fork connecting rods.
- Overload bypass.
- Rubber coated handle.

- 7" moldon polyurethane steering wheels.
- 3" moldon polyurethane load wheels.
- Entry and Exit Rollers.
- 6.25" wide forks.
- 210° steering radius.
- **NEW 18" wide fork model #272854.**



273448

CP3 Pallet Truck

- **2 year pump warranty.**
- **3 mm thick forks.**
- Adjustable fork connecting rods.
- Overload bypass.
- Rubber coated handle.
- 7" moldon polyurethane steering wheels.
- 3" moldon polyurethane load wheels.
- Entry and Exit Rollers.
- 210° steering radius.

Part #	272854	272655	272656	272657	272658	272659	272660	273453	273454	273448
Capacity	5,500 lbs	5,500 lbs	5,500 lbs	5,500 lbs	5,500 lbs	5,500 lbs	5,500 lbs	5,500 lbs	5,500 lbs	5,500 lbs
W-1 x L-1	18" x 48"	21" x 36"	21" x 42"	21" x 48"	27" x 36"	27" x 42"	27" x 48"	21" x 36"	21" x 48"	27" x 48"
W-2	6.25"	6.25"	6.25"	6.25"	6.25"	6.25"	6.25"	6.25"	6.25"	6.25"
L-2	63"	51"	57"	63"	51"	57"	63"	51"	63"	63"
WHL-1 / WHL-2	7" / 3"	7" / 3"	7" / 3"	7" / 3"	7" / 3"	7" / 3"	7" / 3"	7" / 3"	7" / 3"	7" / 3"
H-1 / H-2 / H-3	48.25" / 29" / 17.25"	48.25" / 29" / 17.25"	48.25" / 29" / 17.25"	48.25" / 29" / 17.25"	48.25" / 29" / 17.25"	48.25" / 29" / 17.25"	48.25" / 29" / 17.25"	48.25" / 29" / 17.25"	48.25" / 29" / 17.25"	48.25" / 29" / 17.25"
Weight	171 lbs	153 lbs	161.5 lbs	169.5 lbs	162 lbs	171 lbs	180 lbs	139 lbs	152.5 lbs	164.5 lbs

REFERENCE SCHEMATIC FOR PAGES 46 & 47

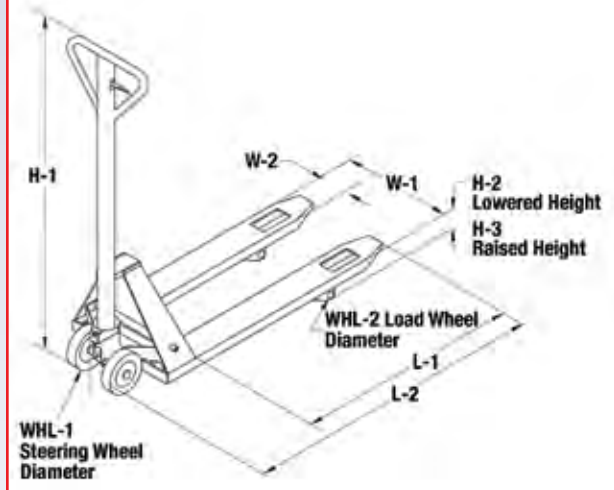

272778



272670

CPIIHD Pallet Truck

- 3 year pump warranty.
- High capacity rating.
- Adjustable fork connecting rods.
- Entry/exit rollers.
- Overload bypass.
- Reinforced forks - 4mm thick.
- Rubber coated handle.
- 7" wide forks.
- 8" moldon polyurethane or 8" nylon steering wheels.
- 3" moldon polyurethane load wheels.
- 180° steering radius.

CPII Pallet Truck

- 3 year pump warranty.
- 2 Models - polyurethane or nylon wheels.
- Adjustable fork connecting rods.
- Entry/exit rollers.
- Overload bypass.
- Reinforced forks - 11 Gauge.
- Rubber coated handle.
- Raised height: 8". Lowered height: 3".
- 7" wide forks.
- 8" moldon polyurethane or 8" nylon steering wheels.
- 3" moldon polyurethane or nylon load wheels.
- 180° steering radius.

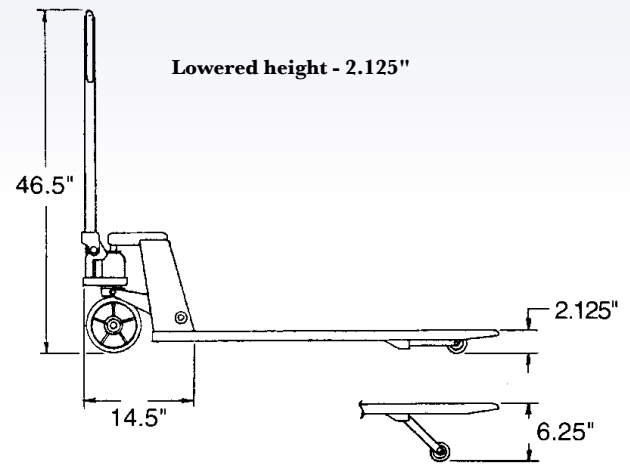

278748

CPII Lowboy Pallet Truck

- 3 year pump warranty.
- Many features are the same as CPII.
- Lowered height of 2.125".
- 7" wide 4mm thick forks.
- 7" moldon polyurethane steering wheels.
- 2" steel load wheels.
- 180° steering radius.

Polyurethane Wheels

Nylon Wheels

LOOK

Part #	272777	272778	272775	272776	272670	278136	278142	278148	278748
Capacity	5,500 lbs	5,500 lbs	5,500 lbs	5,500 lbs	6,600 lbs	4,400 lbs	4,400 lbs	4,400 lbs	4,400 lbs
W-1 x L-1	21" x 48"	27" x 48"	21" x 48"	27" x 48"	27" x 48"	21" x 36"	21" x 42"	21" x 48"	27" x 48"
W-2	7"	7"	7"	7"	7"	7"	7"	7"	7"
L-2	63"	63"	63"	63"	63"	51"	57"	63"	63"
WHL-1 / WHL-2	8" / 3"	8" / 3"	8" / 3"	8" / 3"	8" / 3"	7" / 2"	7" / 2"	7" / 2"	7" / 2"
H-1 / H-2 / H-3	48" / 3" / 8"	48" / 3" / 8"	48" / 3" / 8"	48" / 3" / 8"	48" / 3" / 8"	46.5" / 2.125" / 6.25"	46.5" / 2.125" / 6.25"	46.5" / 2.125" / 6.25"	46.5" / 2.125" / 6.25"
Weight	170 lbs	176 lbs	159.5 lbs	169 lbs	220 lbs	226 lbs	235 lbs	240 lbs	249 lbs



272936

NOT FOR LEGAL TRADE



**Pallet Truck
Chock:
High
Visibility
Yellow**



**FOR MORE PALLET TRUCK OPTIONS
(Chocks and Guards) see page 54.**



273384

Scale Truck

- **NOT FOR LEGAL TRADE.**
- **2 year pump warranty.**
- Weighing accuracy ± 4.4 lbs., or 2.0 Kg.
- LED display scale.
- Mettler-Toledo Hawk scale/sensor.
- UL approved scale operates on rechargeable battery. May be plugged into AC and used while recharging.
- Replacement Battery Pack **#272849.**
- Self-contained battery charger.
- Three position hand control.
- 205° steering radius.
- 7" wide forks.
- 7" moldon polyurethane steering wheels.
- 3" moldon polyurethane load wheels.

Powered Scale Truck

- **NOT FOR LEGAL TRADE.**
- **1 year warranty: DC motor drive, hydraulic pump, controllers and switches.**
- **90-day parts warranty.**
- Built-in battery charger.
- Two 12V-91Ah batteries.
- Requires higher fork clearance. Minimum 3.75" from floor to underside of skid.
- Pallets with bottom board require 4" clearance between top and bottom boards.
- **Part #170015** - Powered Scale Truck without battery.
- Weighing accuracy +/- .22 lbs, or 3.5 oz.
- 6 digit LED display.
- Display uses four "C" sized batteries.

Part #	272936	272938	273384
Model #	SPT27	SPT22	PST
Capacity	5,000 lbs	5,000 lbs	2,900 lbs
W-1 x L-1	27.5" x 47.5"	22.5" x 47.5"	26.5" x 47"
W-2	7"	7"	6.8"
L-2	62.5"	62.5"	64"
WHL-1 / WHL-2	7" / 3"	7" / 3"	8" / 3"
H-1/H-2/H-3	48.25" / 2.9" / 8"	48.25" / 2.9" / 8"	57.5" / 3.5" / 8.25"
Weight	336 lbs	314 lbs	728 lbs w/battery 613 lbs w/out battery

SEE PAGE 46 FOR SCHEMATIC DRAWING.

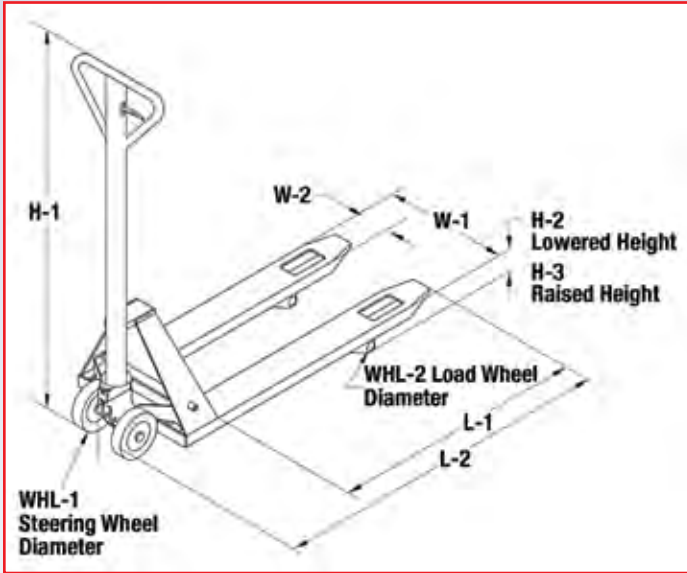

273400

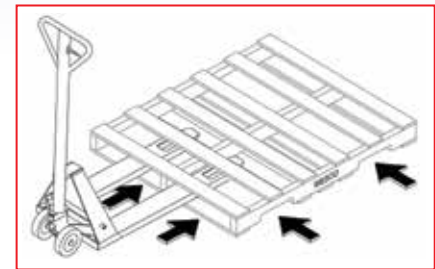

4-Way Pallet Truck

- 3 year pump warranty.
- Overload bypass.
- Reinforced forks - 4mm thick.
- Rubber coated handle.
- 180° steering radius.
- Can enter pallet from all 4 sides.
- Adjustable fork connecting rods.
- Steel 1.70" load wheels.
- 6" polyurethane steering wheels.



272149

MOST ECONOMICALLY PRICED PALLET TRUCK

Economizer Pallet Truck

- 1 year pump warranty.
- Fingertip control: raise - neutral - lower.
- Polyurethane load and steering wheels.
- 190° steering radius.
- 6" wide 3mm thick forks.

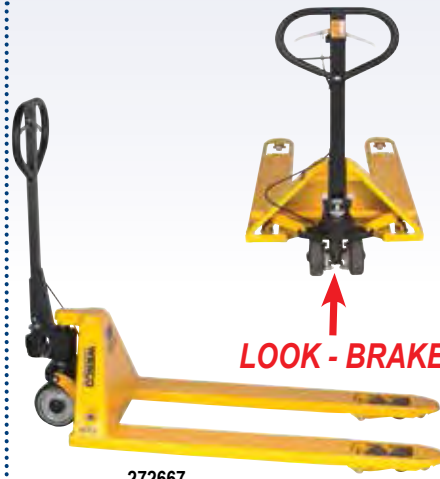

272667

LOOK - BRAKE

Pallet Truck With Hand Brake

- 2 year pump warranty.
- All the same features as the CPI model.
- 6" wide forks.
- 7" moldon rubber steering wheels.
- 3" moldon polyurethane load wheels.
- Disc brake.
- Tandem load wheels.
- Nylon entry rollers.
- 210° steering radius.

Part #	272149	272667	273400
Capacity	4,400 lbs	5,500 lbs	4,000 lbs
W-1 x L-1	27" x 48"	27" x 48"	33" x 48"
W-2	6"	6"	7"
L-2	63"	63"	63.5"
WHL-1 / WHL-2	6.25" / 3"	7" / 3"	6" / 1.70"
H-1 / H-2 / H-3	48.25" / 2.9" / 7.5"	48.25" / 2.9" / 7.25"	47" / 1.75" / 6"
Weight	136 lbs	206 lbs	241 lbs

UNIQUE DESIGN TRANS-ROLLER TRUCKS MOVE FORWARD OR SIDWAYS

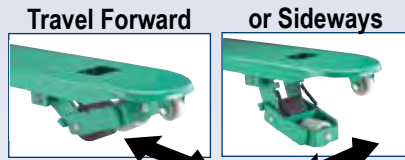

Unique side rolling pallet truck



272740

TransRoller Pallet Truck

- 3 year pump warranty.
- Lowered height 3.4". Raised height 8.5".
- Fork height in standard mode 3.4" lowered, 7" raised.
- Fork height for lateral movement 7.25" lowered, 8.5" raised.
- Adjustable fork connecting rods.
- Overload bypass.
- Ergonomic rubber coated handle.
- Nylon entry rollers.
- 7" wide forks.
- 8" moldon polyurethane steering wheels.
- 3" moldon polyurethane load wheels.
- 210° steering radius.

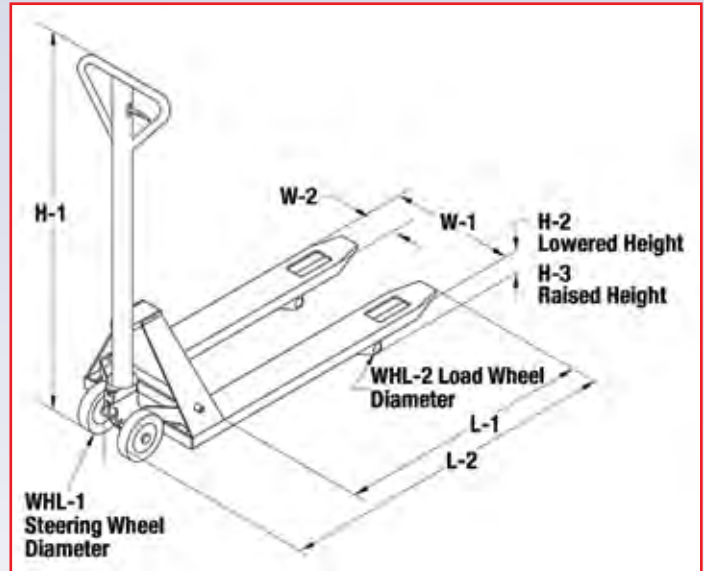

272701

Long Fork Pallet Truck

- 2 year pump warranty.
- Pump, load wheels and steering wheels same as CPI model.
- Overload bypass.
- Rubber coated handle.
- 7" moldon polyurethane steering wheels.
- 3" moldon polyurethane load wheels.
- 78" and 98" forks handle 2 standard size pallets.
- Nylon entry rollers.
- 210° steering radius.



272855

Galvanized Truck

- 1 year pump warranty.
- 7" nylon steering wheels.
- 3" nylon load wheels.
- Galvanized frame and handle.
- Nylon entry rollers.
- 210° steering radius.
- Comfort-grip coated handle.



272152

Stainless Steel Pallet Truck

- 1 year pump warranty.
- For use in food industry and areas where corrosive solutions are needed.
- 6 1/4" wide forks.
- 7" nylon steering wheels.
- 3" nylon load wheels.
- Nylon entry rollers.
- 210° steering radius.
- Comfort-grip coated handle.

Part #	272740	273585	272701	273519	273586	272855	272152
Model #		PT59	PT70	PT78	PT98	GPT	SSPT
Capacity	Standard - 5,000 lbs/ Lateral 2,200 lbs	4,400 lbs	4,400 lbs	4,400 lbs	3,300 lbs	5,500 lbs	5,500 lbs
W-1 x L-1	27" x 48"	27" x 59"	27" x 70"	27" x 78"	27" x 98"	27" x 48"	27" x 48"
W-2	7"	6"	6"	6"	6"	6.25"	6.25"
L-2	63"	75"	86"	93"	114"	62.5"	62.5"
WHL-1 / WHL-2	8" / 3"	7" / 3"	7" / 3"	7" / 3"	7" / 3"	7" / 3"	7" / 3"
H-1/H-2/H-3	Std. mode - 48" / 3.4" / 7" Lateral mode - 48" / 3.4" / 8.5"	48" / 3" / 7"	49" / 3" / 8"	49" / 3" / 8"	48" / 3" / 7"	47.5" / 3" / 7.25"	47.5" / 3" / 7.25"
Weight	210 lbs	220 lbs	244 lbs	256 lbs	347 lbs	155 lbs	164 lbs

REFERENCE SCHEMATIC FOR PAGES 50 & 51

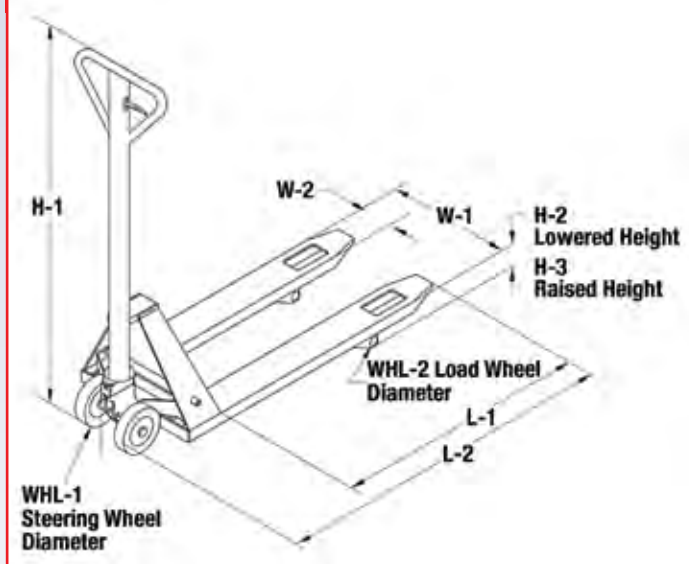

272950

Ergonomic Pallet Tilter

- 1 year pump warranty.
- 5" polyurethane swivel casters and 3" polyurethane load wheels.
- Handle height: 44 1/4"
- Load center: min 7 1/2", max. 15 1/2".
- Lifting range with forks in horizontal position: 3 1/4" to 11".
- Forks tilt up to 90° for accurate load positioning.
- Lifting range with back rest in horizontal position: 29" to 37".
- 6 1/2" wide forks.



273250

Drum Pallet Truck

- 1 year pump warranty.
- For 55-gallon steel drums.
- Lifts drum 4" off ground.
- 8" x 2" nylon steering wheels.
- 3" x 1" nylon load wheels.
- Drum ring raised height - 14.5"
- Drum ring lowered height - 10.25"



272153

Pallet Lifter

- 1 year pump warranty.
- Heavy duty steel construction.
- Pallets with bottom boards must be placed on top of forks.
- 6 1/2" wide forks.
- 6" polyurethane swivel casters.
- 2" polyurethane load wheels.



273286

Semi-Electric Pallet Truck

- 1 year pump warranty.
- Manual lift, power drive.
- Lowered/raised fork height: 3" / 7.5".
- 10" polyurethane drive wheel.
- 3" polyurethane load wheels.
- Speed: 1.6 - 2.4 mph with load.
- 2 batteries - 24V 38Ah.
- 24 volt 8 amp built-in charger.
- 61" steering radius.
- Two fork widths - 20.5" and 27".



273289

Heavy Duty Semi-Electric Pallet Truck

- 1 year pump warranty.
- Manual lift.
- Lowered/raised fork height: 3" / 7".
- 7.25" x 2" polyurethane drive wheel.
- 3" polyurethane load wheels.
- Speed: 2.80 mph with load.
- 2 batteries - 24V 38Ah.
- 24 volt 8 amp charger.
- 62" steering radius.

Part #	272950	273250	272153	273288	273286	273289
Model #	ERPT	PTDL	PLFTR	SEPT2.2-20.5	SEPT2.2-27	SEPT3.3
Capacity	2,200 lbs	660 lbs	1,100 lbs	2,200 lbs	2,200 lbs	3,300 lbs
W-1 x L-1	21.5" x 31"	28.5" x 26"	27" x 44"	20.5" x 48"	27" x 48"	27" x 48"
W-2	6.5"	2.5"	6.5"	6.25"	6.25"	6.25"
L-2	51.67"	41"	61.5"	65.75"	65.75"	69"
WHL-1 / WHL-2	5" / 3"	8" / 3"	6" / 2"	10" / 3"	10" / 3"	7.25" / 3"
H-1 / H-2 / H-3	44.25" / 3.25" / 11"	47.75" / 3" / 8"	40" / 3.5" / 35"	48.5" / 3" / 7.5"	48.5" / 3" / 7.5"	54" / 3" / 7"
Weight	392 lbs	115 lbs	258 lbs	397 lbs	402 lbs	518 lbs

Manual High Lifts

- 1 year pump warranty.
- Two models: Telescoping and Non-Telescoping.
- Moldon polyurethane wheels.
- Loop handles with inside hand control.
- Closed pallets must be placed on top of forks.
- 180° steering radius.
- Comfort coated handles.
- Two stage pump with Quick Lift.



Quick Lift
setting allows operator to raise the forks with fewer strokes. (See chart below.)

Stainless Steel Manual High Lift #272859

- 1 year pump warranty.
- 3" nylon load (WHL-2) and 8" nylon steering (WHL-1) wheels.
- 180° steering radius.
- 304 stainless steel construction, except for 316 stainless forks.



Stainless Model Available

272859
Stainless Steel Manual High Lift

304 Stainless Steel							
Part #	272859	272755	272754	272462	272463	272975	272976
Model #	SSTHL27M	TSHL21	TSHL27	NTSHL21	NTSHL27	TSHL20-33	TSHL27-33
Capacity	2,200 lbs	2,200 lbs	2,200 lbs	2,200 lbs	2,200 lbs	3,300 lbs	3,300 lbs
W-1 x L-1	27" x 46"	21" x 44.5"	27" x 44.5"	21" x 44.5"	27" x 44.5"	20" x 43"	27" x 43"
W-2	6.5"	6.5"	6.5"	6.5"	6.5"	6.5"	6.5"
L-2	61"	63"	63"	56"	56"	63"	63"
WHL-1 / WHL-2	8" / 3"	6" / 3"	6" / 3"	6" / 3"	6" / 3"	6" / 3"	6" / 3"
H-1/H-2/H-3	48"/3.3"/31.5"	48.5"/3.6"/31.5"	48.5"/3.3"/31.5"	48.5"/3.3"/31.5"	48.5"/3.6"/31.5"	48.5"/3.6"/31.5"	48.5"/3.6"/31.5"
Telescoping	Yes	Yes	Yes	No	No	Yes	Yes
Weight	278 lbs	219 lbs	228 lbs	275 lbs	300 lbs	260 lbs	276 lbs
# OF PUMP STROKES TO REACH FULL HEIGHT							
Quick Lift	28	28	28	28	28	21	21
Standard	69	67	67	35	35	63	63

Electric High Lifts

- 1 year pump warranty.
- Two models: Telescoping and Non-Telescoping.
- 12 volt battery charger included.
- 10-12 second lift time unloaded.
- Overload bypass.
- Polyurethane wheels.
- 180° steering radius.
- Comfort coated handles.
- 6 1/2" wide forks.
- 6" moldon polyurethane steering wheels.
- 3" moldon polyurethane load wheels.



272937
Telescoping Models - charger separate.



272461
Non-Telescoping Models - charger built in.

Stainless Steel Electric High Lift #272860

- 1 year pump warranty.
- 3" nylon load (WHL-2) and 8" nylon steering (WHL-1) wheels.
- 180° steering radius.
- 304 stainless steel construction, except for 316 stainless forks.



272860
Stainless Steel Electric High Lift



304 Stainless Steel					
Part #	272860	272939	272937	272460	272461
Model #	SSTHL27E	TEHL21	TEHL27	NTEHL21	NTEHL27
Capacity	2,200 lbs	3,000 lbs	3,000 lbs	2,200 lbs	2,200 lbs
W-1 x L-1	27" x 46"	21" x 45"	27" x 45"	21" x 45"	27" x 45"
W-2	6.5"	6.5"	6.5"	6.5"	6.5"
L-2	61"	60"	60"	60"	63"
WHL-1 / WHL-2	8" / 3"	6" / 3"	6" / 3"	6" / 3"	6" / 3"
H-1/H-2/H-3	48"/3.3"/31.5"	48.5"/3.3"/31"	48.5"/3.3"/31"	48.5"/3.3"/31"	48.5"/3.3"/31"
Telescoping	Yes	Yes	Yes	No	No
Weight	329 lbs	344 lbs	347 lbs	367 lbs	372 lbs

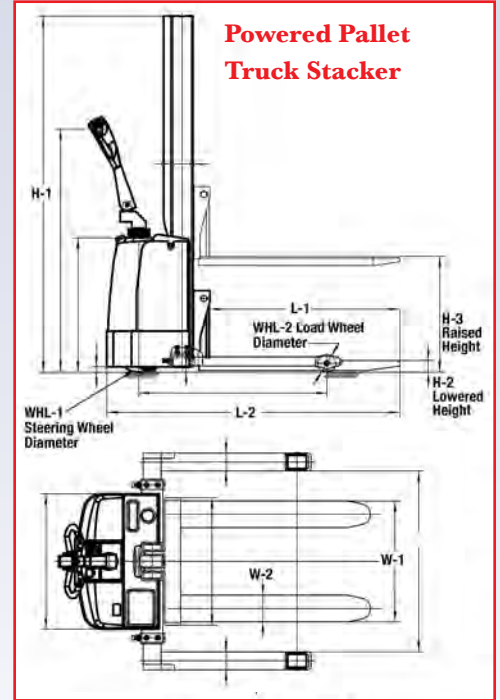
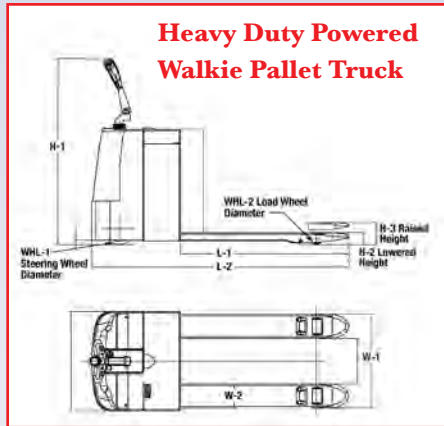
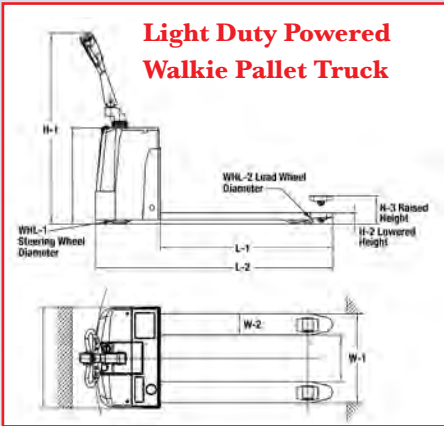

273386

Heavy Duty Powered Walkie Pallet Truck

- 1 year warranty: DC motor drive, hydraulic pump, controllers and switches.
- 90 day parts warranty.
- Three 8V/195 Ah batteries and charger.
- Turn radius of 65.5".
- Lift speed under load: 1.36"/second.
- Lowering speed under load: 1.36"/second.
- Ergonomic handle with:
 - throttle with forward and reverse speeds
 - lift/lower controls
 - belly reverse safety button
 - horn
 - electromagnetic disk brake with automatic dead-man feature when handle is released.
- Key operated.
- 10" polyurethane steering and 3" polyurethane load wheels.

Powered Pallet Truck Stacker

- 1 year warranty: DC motor drive, hydraulic pump, controllers and switches.
- 90 day parts warranty.
- Two 12V/106Ah batteries.
- Built-in 12V/15A charger.
- Turn radius of 53.5".
- Lift speed under load: 3"/second.
- Lowering speed under load: 4"/second.
- Ergonomic handle with:
 - throttle with forward and reverse speeds
 - lift/lower controls
 - belly reverse safety button
 - horn
 - electromagnetic disk brake with automatic dead-man feature when handle is released.
- Key operated.
- 10" polyurethane steering and 3" polyurethane load wheels.
- Adjustable forks.
- Adjustable outriggers - 38" - 52".
- **Optional guard available. Bolt on configuration. #273136.**



273129

Shown with
Optional Bolt On Guard
(#273136).

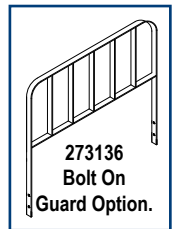

Part # - truck + battery + charger

273382

273129

Part # - truck - no battery

170013*

Capacity

4,400 lbs

2,200 lbs

W-1 x L-1

26.5" x 45"

32" x 45"

W-2

6.8"

4"

L-2

73.75"

69.5"

WHL-1 / WHL-2

10" / 3"

10" / 3"

H-1/H-2/H-3

59" / 3.3" / 8"

77.6" / 1.6" / 60"

Truck Weight with Battery
Truck Weight without Battery

1,370 lbs
860 lbs

1,490 lbs
N/A

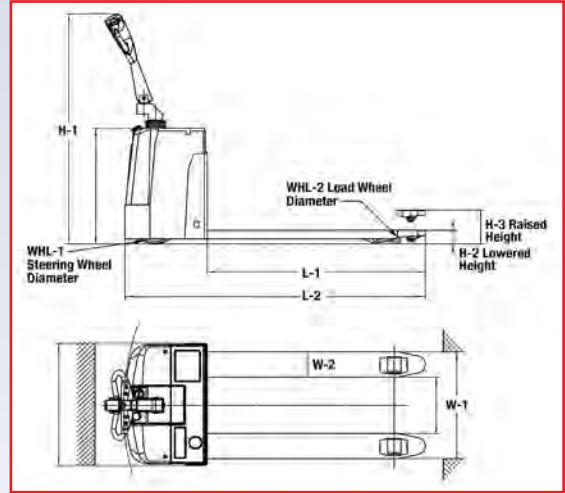

Light Duty
273445



Heavy Duty
273446

Power Pallet Trucks

- 1 year warranty: AC drive, hydraulic pump, controllers and switches.
- 90-day parts warranty.
- Trucks sold complete with battery and charger.
- Ergonomic control handle with:
 - throttle forward and reverse speeds
 - lift and lower controls
 - horn
 - belly reverse safety button
 - electromagnetic disc brake with automatic dead-man feature when handle is released.

Part #	273445	273446
Capacity	3,300 lbs	4,400 lbs
W-1 x L-1	25.5" x 48"	27" x 48"
W-2	6.25"	6.25"
L-2	65"	72"
WHL-1 / WHL-2	10" x 3.5" / 3" x 3.75"	9" x 3" / 3" x 3.75"
H-1 / H-2 / H-3	50" / 3" / 7.67"	50" / 3" / 7.67"
Battery	(2) 12V 80Ah	24V 210 Ah
Steering Angle	205°	180°
Weight	631 lbs	1,147 lbs

EASY AS 1-2-3-GO!

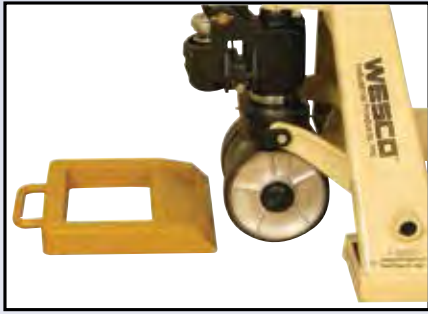

Two Models to Secure Your Pallet Jack

- Both models function well on any surface and will resist slipping.
- To secure pallet jack, simply roll steering wheels up the pallet jack stop or chock incline and into holding area.

Pallet Jack Stop

- Material: black hard rubber.

Part # 272949

Weight 3.5 lbs

OVERALL DIMENSIONS

w: 11.75"
h: 2"
d: 14"



Pallet Truck Chock - High Visibility Yellow

- Material: yellow hard rubber.

Part # 272175

Weight 3.4 lbs

OVERALL DIMENSIONS

w: 11.75"
h: 2"
d: 14"

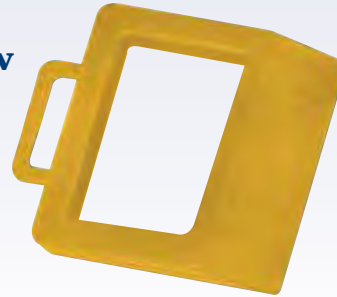

3 in 1 Guard Adapter

- Fits only specific Wesco 27" W pallet trucks: long fork, with brake, CPI and CP3 models.
- Easily attaches to Wesco CPI pallet truck.
- Factory or field installed.
- #272660 CPI Pallet Truck with Mounted Guard - Part #272654 - 245 lbs.
- Guard only kit, field install. Part #272004 - 54 lbs.



Milk Crate Guard



Box Guard

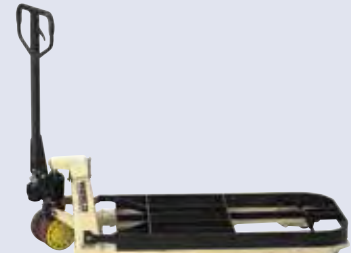

Skid Adapter

3 in 1 Guard featured as an option is three products in one compact design. You no longer need to purchase separate milk crate guards, box guards or skid adapters. Wesco's 3 in 1 guard does it all.

Cargo Backrest

- Fits only specific Wesco 27" W pallet trucks: long fork, with brake, CPI and CP3 models.
- Easy attachment, no drilling, can be field retrofitted.
- Field or factory installed.
- Backrest Only Kit - Part #271999 - 42 lbs.
- Part #272296 - 213 lbs. Assembled CPI Pallet Truck #272660 with Mounted Backrest #271999.

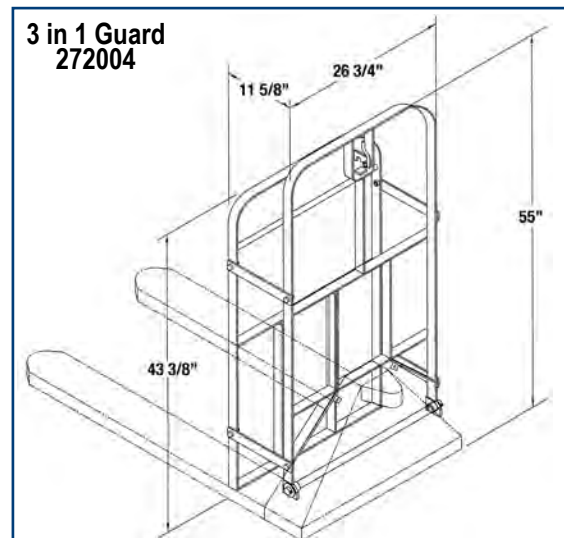
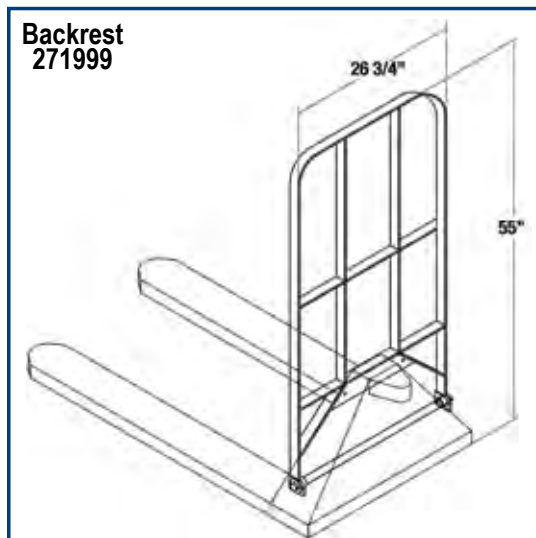

3 in 1 Guard and Cargo Backrest designed for use only on specific Wesco Pallet Trucks. Use on trucks other than Wesco void any and all warranties.

Steel Frame Pedalift Features:

- 750 lb lift capacity.
- Wheel locks are standard on all models.
- Frame and lift heights vary among models.



WPL-54-2222



WPL-54-F



WDPL-54-2222



WDPL-54-F

Two Wheeled Winch Models

- 1-year warranty.
- Manual winch with auto-brake.
- Low maintenance design.
- Front of platform touches the ground on two wheeled model.
- Wheel lock standard.
- All 54" lifts are 60.5" O.A.H. All 40" lifts are 48.5" O.A.H.
- 8" x 2" wheels with .75" precision ball bearings.
- Adjustable forks.

OVERALL DIMENSIONS

w:	22.5"	22.5"	30"	22.5"	22.5"
h:	48.5"	60.5"	60.5"	48.5"	60.5"
d:	32"	32"	32"	32"	32"

Four Wheeled Winch Models

- 1-year warranty.
- Manual winch with auto-brake.
- Low maintenance design.
- Platform on four wheeled model sits 5.75" above the floor.
- Wheel lock standard.
- All 54" lifts are 60.5" O.A.H. All 40" lifts are 48.5" O.A.H.
- 8"x2" wheels with .75" precision ball bearings.
- 3.5" diameter polyurethane ball bearing front swivel casters.
- Adjustable forks.

OVERALL DIMENSIONS

w:	22.5"	22.5"	30"	22.5"	22.5"
h:	48.5"	60.5"	60.5"	48.5"	60.5"
d:	32"	32"	32"	32"	32"

Part #	260015	260016	260017	260018	260019	260020	260021	260022	260023	260024
Model #	WPL-40-1620	WPL-54-2222	WPL-54-2230	WPL-40-F	WPL-54-F	WDPL-40-1620	WDPL-54-2222	WDPL-54-2230	WDPL-40-F	WDPL-54-F
Capacity	750 lbs	750 lbs	750 lbs	750 lbs	750 lbs	750 lbs	750 lbs	750 lbs	750 lbs	750 lbs
Platform or Fork W x L	Platform 20" X 16"	Platform 22" x 22"	Platform 30" x 22"	Fork 3" x 18"	Fork 3" x 18"	Platform 20" x 16"	Platform 22" x 22"	Platform 30" x 22"	Fork 3" x 18"	Fork 3" x 18"
Lift Height	40"	54"	54"	40"	54"	40"	54"	54"	40"	54"
Load Center	10"	10"	10"	10"	10"	10"	10"	10"	10"	10"
Weight	106 lbs	147 lbs	157 lbs	125 lbs	157 lbs	113 lbs	153 lbs	163 lbs	132 lbs	163 lbs



Two Wheeled Hydraulic Models

- 1-year warranty.
- WESCO manufactured hydraulic Pedalift Jack, over 40 years of proven quality.
- Front tip of nose plate touches floor.
- Foot operated hydraulic pump raises platform, foot release lowers platform.
- Wheel lock standard.
- All 54" lifts are 60.5" O.A.H. All 40" lifts are 48.5" O.A.H.
- 8" x 2" wheels with .75" precision ball bearings.
- Adjustable forks.

OVERALL DIMENSIONS

w:	22.5"	22.5"	30"	22.5"	22.5"
h:	48.5"	60.5"	60.5"	48.5"	60.5"
d:	32"	32"	32"	32"	32"



Four Wheeled Hydraulic Models

- 1-year warranty.
- WESCO manufactured hydraulic Pedalift Jack, over 40 years of proven quality.
- Available 304 stainless steel construction:
 - Stainless model has 8" x 2" polyurethane tread on polypropylene hub, non-marking wheels with 440 stainless sealed 3/4" precision ball bearing.
 - 304 stainless hydraulic jack.
 - 304 stainless swivel casters with plain bore 3.5" hard rubber wheels.
- Foot operated hydraulic pump raises platform, foot release lowers platform.
- Platform sits 5.75" above the floor.
- Wheel lock standard.
- All 54" lifts are 60.5" O.A.H. All 40" lifts are 48.5" O.A.H.
- 8" x 2" wheels with .75" precision ball bearings on steel models.
- 3.5" diameter polyurethane ball bearing front swivel caster on steel models.
- Adjustable forks.

OVERALL DIMENSIONS

w:	22.5"	22.5"	30"	22.5"	22.5"	22.5"	22.5"
h:	48.5"	60.5"	60.5"	48.5"	60.5"	60.5"	60.5"
d:	32"	32"	32"	32"	32"	32"	32"

304 Stainless Steel

Part #	260001	260002	260003	260006	260007	260008	260009	260010	260011	260012	260186	260197
Model #	PL-40-1620	PL-54-2222	PL-54-2230	PL-40-F	PL-54-F	DPL-40-1620	DPL-54-2222	DPL-54-2230	DPL-40-F	DPL-54-F	SSDPL-54-2222	SSDPL-54-F
Capacity	750 lbs	750 lbs	750 lbs	750 lbs	750 lbs	750 lbs	750 lbs	750 lbs	750 lbs	750 lbs	750 lbs	750 lbs
Platform or Fork W x L	Platform 20" x 16"	Platform 22" x 22"	Platform 30" x 22"	Fork 3" x 18"	Fork 3" x 18"	Platform 20" X 16"	Platform 22" x 22"	Platform 30" x 22"	Fork 3" x 18"	Fork 3" x 18"	Platform 22" x 22"	Fork 3" x 18"
Lift Height	40"	54"	54"	40"	54"	40"	54"	54"	40"	54"	54"	54"
Load Center	10"	10"	10"	10"	10"	10"	10"	10"	10"	10"	10"	10"
Weight	112 lbs	156 lbs	166 lbs	131 lbs	166 lbs	119 lbs	166 lbs	172 lbs	138 lbs	172 lbs	175 lbs	181 lbs

Cylinder Truck?

See page 28.



Universal Lift

- 1-year warranty.
- Two straps with buckles to help secure load, 9' wrap around and 5' front to back.
- Manual winch with auto brake.
- Two 8" wheels and two 3 1/2" polyurethane casters.
- Lowered platform sits 6" above ground.
- Ideal for placing rental equipment on to pickup truck or into van.

OVERALL DIMENSIONS

w: 29.25"
h: 61"
d: 46.4"

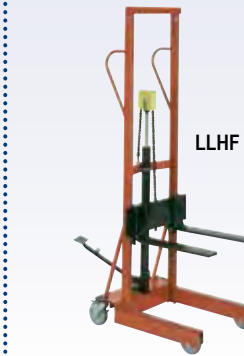

Hydraulic Lite-Lift

- 1-year warranty.
- WESCO manufactured hydraulic Pedalift Jack, over 40 years of proven quality.
- Foot operated hydraulic pump.
- Release foot pedal for controlled lowering.
- Casters with wheel locks.
- Adjustable forks.

OVERALL DIMENSIONS

w: 20" 20"
h: 70.5" 70.5"
d: 30" 30"



Platform Option

- Provides the utility of two units.
 - Easy installation - no tools required.
- Part # - 260157
Model # - POK



To order option, add Part # or Model # to Lite-Lift Part # or Model #.



Winch Lite-Lift

- 1-year warranty.
- Manual winch with auto-brake.
- No catches to release.
- Low maintenance.
- Casters with wheel locks.

OVERALL DIMENSIONS

w: 20" 20"
h: 70.5" 70.5"
d: 30" 30"



Hydraulic Cylinder Lift

- 1-year warranty.
- WESCO manufactured hydraulic Pedalift Jack, over 40 years of proven quality.
- Easily lifts and transports gas cylinders.
- Swivel casters make maneuvering in tight places easier.
- Two models:
 - Foot operated hydraulic pump.
 - Manual winch with auto-brake.
- Maximum cylinder diameter 9.5".
- Casters with wheel locks.

OVERALL DIMENSIONS

w: 20" 20"
h: 54" 58"
d: 29.25" 29.25"

Part #	260161	260163	260130	260150	260151	260152	260153
Model #	LLHPB	LLWPB	ULP2630	LLHP	LLHF	LLWP	LLWF
Capacity	300 lbs	300 lbs	750 lbs	500 lbs	500 lbs	500 lbs	500 lbs
Platform or Fork W x L	Platform 12" x 20"	Platform 12" x 20"	Platform 26" x 30"	Platform 20" x 20"	Fork 3" x 19" x .75"	Platform 20" x 20"	Fork 3" x 19" x .75"
Lift Height	40" / Hydraulic	40" / Winch	54"	54"	54"	54"	54"
Lowered Height	1/4"	1/4"	6"	5.75"	4.25"	5.75"	4.25"
Caster / Wheel Size	5"	5"	3.5" / 8"	5"	5"	5"	5"
Front Leg Span	N/A	N/A	N/A 19.75" OD	15.25" ID x 20" OD	15.25" ID 20" OD	15.25" ID 20" OD	15.25" ID 20" OD
Load Center	10"	10"	6"	10"	10"	10"	10"
Weight	165 lbs	152 lbs	224 lbs	139 lbs	157 lbs	103 lbs	124 lb

WESCO® TRIPLE TRUCK / ALUMINUM PEDALIFTS



261160 Frame w/
261161 Drum Lifter



261160 Frame w/
261162 Adjustable Forks



261160 Frame w/
261163 Platform

**A 5 Year Guarantee
Against Weld Failure.
A Wesco Quality Exclusive.**

Aluminum Frame Pedalifts features:

- Aluminum construction for lightweight ruggedness.
- 20" deep x 22" wide platform size.
- Wheel locks are standard on all models.
- Front of platform touches the floor.
- Frame and lift heights vary among models.

Triple Truck



1-YEAR WARRANTY, PATENT NO. US9,139,214B2.

- Handles most standard rim 30, 55 and 85 gal. steel, poly and fiber drums.
- Manual winch with auto brake.
- 3 Models of Lifting Attachments - **No tools required:**
 - #261161 - Gator Grip® Drum Lifter Attachment
 - #261162 - Adjustable Width Forks -6" to 19 1/2" O.D.
 - #261163 - Platform - 21 1/4" W x 28 1/2" D. (Optional slip-on over forks.) Requires adjustable fork option.

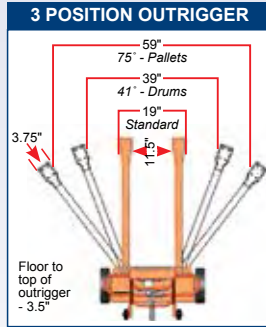

- Carriage lock, lock carriage in place at any position.
- Easy load rollers assist loading onto a truck bed.

HOW TO ORDER:

Frame and attachments ordered separately.

1. Purchase basic frame - **Part #261160.**
 2. Select lifting attachment.
 - a. Gator Grip® Drum Lifter - **Part #261161.**
 - b. Adjustable Forks - **Part #261162.**
 - c. Slip-on Platform* - **Part #261163.**
- (Requires adjustable fork option.)

- Low-profile 3" debris deflecting neoprene swivel casters.
- Floor to top of leg height - 3.75".
- 10" x 2.75" poly hub solid rubber wheels - **Part # 150698.**
- Wheel lock - pedal activated.
- Lever operated outrigger adjustment - 3 positions.
- Outrigger angle can be changed even under full load.

OVERALL DIMENSIONS

w:	30"	16"
h:	70.75"	33"
d:	52.25"	12"

LOOK



WMPL-54-2022
Winch/Platform

Two Wheeled Winch Models

- 1-year warranty.
- Manual winch with auto-brake.
- Light weight minimizes the effort required for moving and lifting.
- Wheel lock standard.
- 8"x2" wheels with .75" ball bearings.

OVERALL DIMENSIONS

w:	22.5"	w:	22.5"
h:	48.5"	h:	60.5"
d:	32"	d:	32"



MPL-54-2022
Hydraulic/Platform

Two Wheeled Hydraulic Models

- 1-year warranty.
- Foot operated hydraulic pump raises platform, foot release lowers platform.
- WESCO manufactured hydraulic Pedalift Jack, over 40 years of proven quality.
- Wheel lock standard.
- 8"x2" wheels with .75" ball bearings.

OVERALL DIMENSIONS

w:	22.5"	w:	22.5"
h:	48.5"	h:	60.5"
d:	32"	d:	32"

Part #	261160	261161	261162	261163	260025	260026	260004	260005
Model #	TTF	TTF-GG	TTF-AF	TTF-P	WMPL-40-2022	WMPL-54-2022	MPL-40-2022	MPL-54-2022
Capacity	750 lbs	750 lbs	750 lbs	750 lbs	400 lbs	400 lbs	400 lbs	400 lbs
Platform or Fork W x L	FRAME ONLY	GATOR GRIP	ADJ. FORKS 3" x 26.75"	PLATFORM* 21.25" x 28.125"	Platform 22" x 20"	Platform 22" x 20"	Platform 22" x 20"	Platform 22" x 20"
Front Leg Span	SEE CHART ABOVE				N/A	N/A	N/A	N/A
Lowered Height	N/A	28.75"	4"	5"	N/A	N/A	N/A	N/A
Lift Height	N/A	69"	62"	62.125"	40"	54"	40"	54"
Caster / Wheel Size	3" / 10"	N/A	N/A	N/A	8" x 2"	8" x 2"	8" x 2"	8" x 2"
Load Center	N/A	16"	16"	16"	10"	10"	10"	10"
Weight	224 lbs	32 lbs	30 lbs	6 lbs	61 lbs	68 lbs	71 lbs	77 lbs

*Requires Adjustable Fork Option



SINCE 1948



273510
Fixed Base
(Forks Down)



273510
Fixed Base
(Forks Up)

273516
Counter-balance Straddle
(Forks Down)



Hand Winch Lifters

- Capacities: 350, 400 and 500 lbs.
- Aluminum and steel construction.
- 8" rear wheels and 2" front swivel casters are non-marking.
- Forks can be inverted for two different lift heights. Fork size: 4"W x 22.5"L x 1.75"H.
- Winch crank handle locks to secure carriage.
- Three models:
 - **Fixed Base** used in narrow work spaces. Base legs: 13" inside width x 21.5" overall width.
 - **Adjustable Straddle** with adjustable legs 21.5" to 36" inside width and 29" to 44" outside width.
 - **Counter-balance Straddle**. Short legs get you close to load when there is no room for standard legs. 5" polyurethane rear swivel casters with brakes and 4" front wheels.
- Top of frame rollers facilitates laying truck horizontal for transport.



273513
Adjustable Straddle
(Forks Down)

OVERALL DIMENSIONS

w:	24"	24"	29"	29"	29"	29"	29"	29"
h:	68"	68"	79"	68"	68"	68"	68"	68"
d:	35"	35"	43"	43"	43"	47"	47"	47"

Part #	273510	273511	273512	273513	273514	273515	273516	273517
Model #	HWLFX-4	HWLFX-5	HWLSD-3.5	HWLSD-4	HWLSD-5	HWLCB-3.5	HWLCB-4	HWLCB-5
Capacity	400 lbs	500 lbs	350 lbs	400 lbs	500 lbs	350 lbs	400 lbs	500 lbs
Base	Fixed	Fixed	Adjustable Straddle	Adjustable Straddle	Adjustable Straddle	Counter-balance Straddle	Counter-balance Straddle	Counter-balance Straddle
Max. Lift Range*	98" / 120"	47" / 70"	120" / 142"	98" / 120"	47" / 70"	120" / 142"	98" / 120"	47" / 70"
Lowered Height Range*	3.5" / 25"	3.5" / 27.5"	1.25" / 21.5"	1.25" / 21.5"	1.25" / 21.5"	1.25" / 21.5"	2" / 25"	2" / 25"
Load Center	11.25"	11.25"	11.25"	11.25"	11.25"	11.25"	11.25"	11.25"
Weight	154 lbs	143 lbs	176 lbs	165 lbs	154 lbs	405 lbs	394 lbs	383 lbs

* Forks down / forks up dimensions.

Optional Removable Steel Platform

- Fits over forks.
- Size: 20.5"W x 24.25"L.
- Weight: 26 lbs.
- **Part #273518**

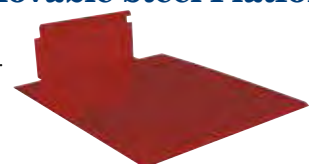



1,000 LB. HYDRAULIC & WINCH PLATFORM STACKERS

Hydraulic Stackers features:

- Floor locks, safety screen and foot guard are standard on all models.
- Forks touch the floor on all fork models.
- Front phenolic wheels are 5" diameter.
- Rear phenolic swivel casters are 4" diameter.
- Hydraulic jack manufactured by WESCO.
- "S"tandard line features one piece platform guide rail.
- "E"conomy line offers an economical price value.
- Foot pedal - pump and release.

**A 5 Year Guarantee Against Weld Failure.
A Wesco Quality Exclusive.**



SPL-60-2424



ESPL-60-2424



SPL-80-3032



ESPL-60-3032

Wesco Platform Models

- 1-year warranty.
- WESCO manufactured hydraulic Stacker Jack, over 40 years of proven quality.
- 24" x 24" heavy gauge platform with 5.75" lowered height.
- 15" load center.
- Base leg span - 15" inside, 21" outside.
- **NEW Low Profile Outrigger Option available.**

OVERALL DIMENSIONS

w:	25.5"	25.5"	25.5"	25.5"	25.5"	25.5"
h:	75"	72"	83"	80"	94"	92"
d:	40"	40"	38"	40"	40"	40"
	Standard	Economy	Standard	Economy	Standard	Economy

Wesco Large Platform Models

- 1-year warranty.
 - WESCO manufactured hydraulic Stacker Jack, over 40 years of proven quality.
 - 30" deep x 32" wide heavy gauge platform with 5.25" lowered height.
 - 18" load center.
 - Base leg span - 25.5" inside, 32" outside.
 - **NEW Low Profile Outrigger Option available.**
- See below.

OVERALL DIMENSIONS

w:	32"	32"	32"	32"	32"	32"
h:	75"	72"	83"	80"	94"	92"
d:	44.5"	44.5"	44.5"	44.5"	44.5"	44.5"
	Standard	Economy	Standard	Economy	Standard	Economy

Part #	260032	260044	260033	260045	260034	260046	260038	260050	260039	260051	260040	260052
Model #	SPL-60-2424	ESPL-60-2424	SPL-68-2424	ESPL-68-2424	SPL-80-2424	ESPL-80-2424	SPL-60-3032	ESPL-60-3032	SPL-68-3032	ESPL-68-3032	SPL-80-3032	ESPL-80-3032
Capacity	1,000 lbs	1,000 lbs	1,000 lbs	1,000 lbs	1,000 lbs	1,000 lbs	1,000 lbs	1,000 lbs	1,000 lbs	1,000 lbs	1,000 lbs	1,000 lbs
Platform/Fork W x L	24" x 24"	24" x 24"	24" x 24"	24" x 24"	24" x 24"	24" x 24"	32" x 30"	32" x 30"	32" x 30"	32" x 30"	32" x 30"	32" x 30"
Lift Height	60"	60"	68"	68"	80"	80"	60"	60"	68"	68"	80"	80"
Load Center	15"	15"	15"	15"	15"	15"	18"	18"	18"	18"	18"	18"
Weight	233 lbs	226 lbs	248 lbs	234 lbs	274 lbs	263 lbs	272 lbs	265 lbs	295 lbs	273 lbs	317 lbs	298 lbs
Low Profile Option	Yes	Yes	Yes	Yes	Yes	Yes	Yes	Yes	Yes	Yes	Yes	Yes

1,000 lb Capacity Winch Stacker

- 1-year warranty.
- Heavy duty 1,000 lb capacity.
- Heavy duty winch with auto brake.
- Floor lock and safety screen are standard.
- Swivel casters - 4" x 2" phenolic. Load wheels - 5" x 2" phenolic.
- Lowered height - 5.25".
- **NEW Low Profile Outrigger Option available.**



SWPL-68-2424

OVERALL DIMENSIONS

w:	24"
h:	83.25"
d:	41"

Part #	270214
Model #	SWPL-68-2424
Capacity	1,000 lbs
Platform/Fork W x L	24" x 24"
Lift Height	70"
Load Center	15"
Weight	238 lbs
Low Profile Option	Yes

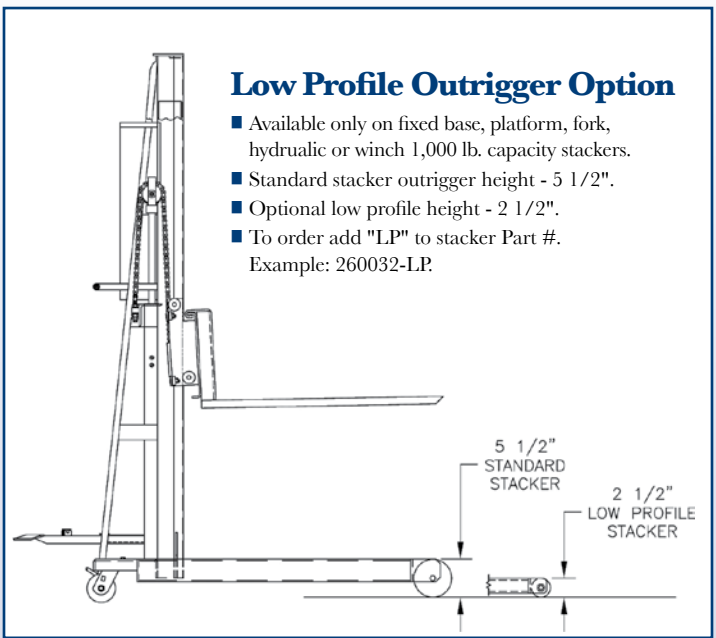

SINCE 1948



1,000 LB. FORK STACKERS

**A 5 Year Guarantee Against Weld Failure.
A Wesco Quality Exclusive.**

Wesco Fork Model

- **1-year warranty.**
- **1" thick x 3" wide x 25" long forks.**
- Adjustable fork range:
minimum - 6.125" O.D.
maximum - 25" O.D.
- 15" load center.
- 25.5" overall width; 40" depth.
- Base leg span - 15" inside, 21" outside.
- Forks lower to ground.
- **WESCO manufactured hydraulic Stacker Jack, over 40 years of proven quality.**
- **NEW Low Profile Outrigger Option available. (See page 60.)**



OVERALL DIMENSIONS

w:	25.5"	25.5"	25.5"	25.5"	25.5"	25.5"
h:	75"	72"	83"	80"	94"	92"
d:	44.5"	44"	44.5"	44"	44.5"	44"
	Standard	Economy	Standard	Economy	Standard	Economy

Part #	260035	260047	260036	260048	260037	260049
Model #	SFL-56-25	ESFL-56-25	SFL-64-25	ESFL-64-25	SFL-76-25	ESFL-76-25
Capacity	1,000 lbs	1,000 lbs	1,000 lbs	1,000 lbs	1,000 lbs	1,000 lbs
Platform/Fork W x L	3" x 25"	3" x 25"	3" x 25"	3" x 25"	3" x 25"	3" x 25"
Lift Height	56"	56"	64"	64"	76"	76"
Load Center	15"	15"	15"	15"	15"	15"
Weight	265 lbs	258 lbs	273 lbs	266 lbs	306 lbs	295 lbs
Low Profile Option	Yes	Yes	Yes	Yes	Yes	Yes

Straddle Fork Model

- **1-year warranty.**
- **1" thick x 3" wide x 30" long forks.**
- Adjustable fork range:
minimum - 6.125" O.D.
maximum - 25" O.D.
- 18" load center.
- 32" overall width; 44" depth.
- Base leg span - 25.5" inside, 32" outside.
- Forks lower to ground.
- **WESCO manufactured hydraulic Stacker Jack, over 40 years of proven quality.**
- **NEW Low Profile Outrigger Option available. (See page 60.)**



Wide Straddle Fork Model

- **1-year warranty.**
- **1" thick x 3" wide x 30" long forks.**
- Base leg span - 42" inside, 48.75" outside.
- Adjustable fork range:
minimum - 6.125" O.D.
maximum - 25" O.D.
- Overall width 48.75", depth 48.25".
- Forks lower to the ground.
- **NOT AVAILABLE - Low profile option.**
- **WESCO manufactured hydraulic Stacker Jack, over 40 years of proven quality.**



OVERALL DIMENSIONS

w:	32.5"	32.5"	32.5"	32.5"	32.5"	32.5"	48.5"
h:	75"	72"	83"	80"	94"	92"	72.5"
d:	48"	48"	48"	48"	48"	48"	49"
	Standard	Economy	Standard	Economy	Standard	Economy	Wide

Part #	260041	260053	260042	260054	260043	260055	260075
Model #	SFL-56-30S	ESFL-56-30S	SFL-64-30S	ESFL-64-30S	SFL-76-30S	ESFL-76-30S	ESFL-56-30-42S
Capacity	1,000 lbs	1,000 lbs	1,000 lbs	1,000 lbs	1,000 lbs	1,000 lbs	1,000 lbs
Fork W x L	3" x 30"	3" x 30"	3" x 30"	3" x 30"	3" x 30"	3" x 30"	3" x 30"
Lift Height	56"	56"	64"	64"	76"	76"	56"
Load Center	18"	18"	18"	18"	18"	18"	18"
Weight	288 lbs	281 lbs	298 lbs	289 lbs	333 lbs	322 lbs	352 lbs
Low Profile Option	Yes	Yes	Yes	Yes	Yes	Yes	No

Adjustable Fork Model
272940

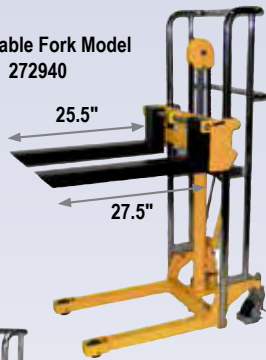

Chrome plated platform is an option.



With optional platform
#272942

Value Lift

- Adjustable 4" wide x 25.5" long forks.
- Optional, removable chrome plated 22" wide x 26" long platform.
- Foot operated hydraulic pump.
- Two 5" polyurethane swivel casters with brake and two 3" polyurethane rigid wheels.
- Two lift heights: 47" and 59".
- Chrome plated rails and handle.
- Ships KD.
- #272942 Optional Platform fits both Manual and Electric Value Lift Stackers.

OVERALL DIMENSIONS

w: 22.5"	22.5"	22"
h: 55"	70"	1"
d: 36"	37"	26"



Control Panel



VLP-59

Electric Value Lift Stackers

- Adjustable 4" wide x 25.5" long forks.
- Optional, removable 22" wide x 26" long platform.
- Two 5" polyurethane swivel casters with brake and two 3" polyurethane rigid wheels.
- Two lift heights: 47" and 59".
- Chrome plated rails and handles.
- UL approved charger.
- Sealed maintenance-free battery.
- Keyed on/off switch.
- Raise/lower controls.
- #272942 Optional Platform fits both Manual and Electric Value Lift Stackers.

OVERALL DIMENSIONS

w: 22.5"	22.5"
h: 55"	68"
d: 44"	44"

Manual and Electric Office Lifts

- Ideal for narrow aisles.
- Great for offices.
- Two models, manual and electric.
- Lightweight, but sturdy.
- Sealed battery and automatic charger built in.
- Remote up and down pendant for electric model.
- 9/16" thick plastic platform.

OVERALL DIMENSIONS

w: 23.5"	23.5"
h: 71.5"	78"
d: 32"	34"

With optional support backrest and foldable platform.



Premium Light Duty Winch Lift

- 1 Year Warranty on parts only.
- Zinc-plated finish.
- Suitable for clean environments.
- Swivel caster, 3/4" polyurethane dual wheel.
- Easy maneuvering in tight or narrow spaces.
- 2" lifting strap.
- Manual winch with auto brake.
- Optional zinc-plated cargo support backrest. Part #274531.
- Optional 304 stainless steel foldable platform. Part #274530.

OVERALL DIMENSIONS

w: 23.25"
h: 54.125"
d: 29.25"

Part #	Value Lift			Electric Value Lift Stackers		Manual and Electric Office Lifts		Premium Light Duty Winch Lift
	272940	272941	272942	273203	273204	272467	272468	
Model #	VL47	VL59	VLRP	VLP-47	VLP-59	MOL	EOL	DWL-43
Capacity	880 lbs	880 lbs	N/A	880 lbs	880 lbs	220 lbs	220 lbs	265 lbs
Platform or Fork W x L	Fork 4" x 25.5"	Fork 4" x 25.5"	Platform 22" x 26"	Fork 4" x 25.5"	Fork 4" x 25.5"	Platform 18" x 23"	Platform 18" x 23"	15.125" x 23.25"
Lift Height	3.5" - 47"	3.5" - 59"	N/A"	3.5" - 47"	3.5" - 59"	58.5"	66"	43"
Lowered Height	3.5"	3.5"	N/A	3.5"	3.5"	5"	5"	3.25"
Adj. Fork Width	8.5" - 19.5"	8.5" - 19.5"	N/A	8.25" - 21.5"	8.25" - 21.5"	N/A	N/A	N/A
Swivel Casters	5" Locking Polyurethane	5" Locking Polyurethane	N/A	5" Locking Polyurethane	5" Locking Polyurethane	5" x 1.25" Hard Rubber	5" x 1.25" Hard Rubber	3/4" Dual Wheel Polyurethane
Load Wheels	3" Rigid Polyurethane	3" Rigid Polyurethane	N/A	3" Rigid Polyurethane	3" Rigid Polyurethane	2.75" x 1.25" Hard Rubber	2.75" x 1.25" Hard Rubber	7.5" x 1.25" Rubber
Battery	N/A	N/A	N/A	12V 80AH	12V 80AH	N/A	12V	N/A
Load Center	12.75"	12.75"	N/A	12.75"	12.75"	9.25"	9.25"	15.25"
Weight	178 lbs	187 lbs	10 lbs	269 lbs	280 lbs	104 lbs	146 lbs	55 lbs

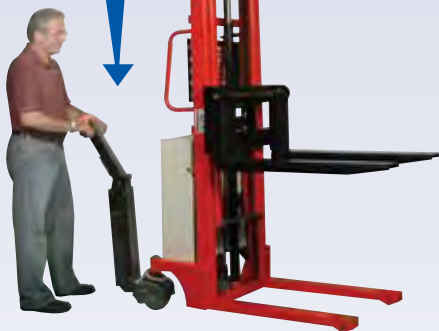

2,200 lb Capacity Power Drive Stackers

- **6 Month Warranty on parts only.**
- **Can not be used with pallets - only skids without bottom slates.**
- Lift height of 98 3/4". Dual chain lift.
- Includes two, 12 volt, 187 AH, sealed batteries and a separate UL approved charger.
- Power propulsion system takes the effort out of moving heavy loads. Also provides easy steering.
- Fingertip control provides variable forward and reverse speeds.
- Automatic safety stop on top of control post. Unit shuts down when safety stop comes into contact with an obstacle.
- Load wheels, steering wheel and drive wheel are all moldon polyurethane.
- Adjustable forks.

OVERALL DIMENSIONS

w: 35"
h: 70" - 117.5"
d: 64"

Part #	272943
Model	EKS-10
Capacity	2,200 lbs
Lowered Mast Height	70"
Raised Mast Height	117.5"
Leg ID/OD	19" / 27"
Fork Size W x L	5" x 35.25"
Outside Fork Spread	12" - 29" - Adjustable
Lowered Fork Height	2.6"
Raised Fork Height	98.25"
Load Center	17.5"
Weight	826 lbs

Features of Counter-Balance Powered Line of Stackers

- **Meets ANSI B56.10 specifications.**
- **Maximum lift capacity - 1,000 lbs.**
- **Remote control, floor lock, and safety screen are standard on all models.**
- **With a minimally charged battery, unit can be used while recharging.**
- **Easy to read illuminated battery status voltmeter - no extra cost!**



Standard features include:
remote control
voltmeter
on/off switch.



Counter-Balance Powered Stackers

- **1-year warranty.**
- **Proven quality: WESCO manufactured Hydraulic Cylinder.**
- Battery and charger included.
- Applications include:
 - Loading and unloading trucks.
 - Positioning dies.
 - Feeding material to presses.
- 25" long forks standard.
- 30" long fork models available, 850 lb. max. capacity.
- Order enough weight kits for your planned load. (See chart below.)
- **AC models not available.**



261039

Note: Counter-Balance Stackers require appropriate counter-weights. See chart below.

OVERALL DIMENSIONS

w: 26.5"	26.5"	26.5"
h: 75"	83"	94"
d: 59.5"	59.5"	59.5"

Part #	261037	261038	261039
Model #	PCBFL-56-25	PCBFL-64-25	PCBFL-76-25
Capacity	1,000 lbs	1,000 lbs	1,000 lbs
Fork W x L	3" x 25"	3" x 25"	3" x 25"
Outside Fork Spread	6" - 25" - Adjustable	6" - 25" - Adjustable	6" - 25" - Adjustable
Lift Height	56"	64"	76"
Wheel: Front Rear	5" 5"	5" 5"	5" 5"
Load Center	13"	13"	13"
Weight*	560 lbs	574 lbs	611 lbs

*Weight of stacker without counterweights.

Counter-Balance Weights

Part #	261041	261042	261043
Counterweight	200 lbs	400 lbs	600 lbs
Stacker Load Capacity	334 lbs	668 lbs	1,000 lbs

WESCO® 1,000 LB. POWER LIFT STACKERS



261024

Platform Model

- 1-year warranty.
- Proven quality: WESCO manufactured Hydraulic Cylinder.
- Battery and charger included.
- Lowered height 5.75"
- Phenolic wheels on front and phenolic casters on rear.
- Power Drive Option available: see page 67 for details. Add "-PD" to end of Part #.
- 110V AC models available (Special Order). Add AC to end of Part #.
- NEW Low Profile Outrigger Option available.

OVERALL DIMENSIONS

w:	25.5"	25.5"	25.5"
h:	72"	80"	92"
d:	36"	36"	36"

24" x 24" Platform Models



261033

Fork Model

- 1-year warranty.
- Proven quality: WESCO manufactured Hydraulic Cylinder.
- Battery and charger included.
- Forks lower to floor on all models.
- 5" phenolic wheels on front, 4" swivel on rear.
- Power Drive Option available: see page 67 for details. Add "-PD" to end of Part #.
- 110V AC models available (Special Order). Add AC to end of Part #.
- Adjustable fork range: minimum - 6" O.D. maximum - 25" O.D.
- NEW Low Profile Outrigger Option available.

OVERALL DIMENSIONS

w:	25.5"	25.5"	25.5"
h:	72"	80"	92"
d:	44.5"	44.5"	44.5"

Fork Models



261035

Adjustable Span Straddle Model

- 1-year warranty.
- Proven quality: WESCO manufactured Hydraulic Cylinder.
- Battery and charger included.
- Forks lower to floor on all models.
- Extra deep (40") straddle legs and forks for lifting pallets.
- Versatile adjustable span straddle legs can be set from 34" to 50" inside dimension to handle most standard pallets.
- Power Drive Option available: see page 67 for details. Add "-PD" to end of Part #.
- 110V AC models available (Special Order). Add AC to end of Part #.
- Adjustable fork range: minimum - 6" O.D., maximum - 25" O.D.
- NOT AVAILABLE - Low profile option.

OVERALL DIMENSIONS

w:	54" Max	54" Max	54" Max
h:	72"	80"	92"
d:	58.75"	58.75"	58.75"

Adjustable Straddle Fork Models

Part #	261022	261023	261024	261028	261029	261030	261034	261035	261036
Model #	PESPL-60-2424	PESPL-68-2424	PESPL-80-2424	PESFL-56-25	PESFL-64-25	PESFL-76-25	PASFL-56-40S	PASFL-64-40S	PASFL-76-40S
Capacity	1,000 lbs	1,000 lbs	1,000 lbs	1,000 lbs	1,000 lbs	1,000 lbs	1,000 lbs	1,000 lbs	1,000 lbs
Platform or Fork W x L	Platform 24" x 24"	Platform 24" x 24"	Platform 24" x 24"	Fork 3" x 25"	Fork 3" x 25"	Fork 3" x 25"	Fork 3" x 40"	Fork 3" x 40"	Fork 3" x 40"
Lift Height	60"	68"	80"	56"	64"	76"	56"	64"	76"
Leg ID/OD	15"/21"	15"/21"	15"/21"	15"/21"	15"/21"	15"/21"	34" to 50" ID Adj.	34" to 50" ID Adj.	34" to 50" ID Adj.
Wheel:									
Front	5" phenolic	5" phenolic	5" phenolic	5" phenolic	5" phenolic	5" phenolic	5" phenolic	5" phenolic	5" phenolic
Rear	4" phenolic swivel	4" phenolic swivel	4" phenolic swivel	4" phenolic swivel	4" phenolic swivel	4" phenolic swivel	4" phenolic swivel	4" phenolic swivel	4" phenolic swivel
Load Center	15"	15"	15"	15"	15"	15"	20"	20"	20"
Weight	418 lbs	428 lbs	457 lbs	452 lbs	460 lbs	489 lbs	510 lbs	518 lbs	554 lbs
Low Profile Option	Yes	Yes	Yes	Yes	Yes	Yes	No	No	No

30" x 32" Platform Models

Straddle Fork Models

Part #	261025	261026	261027	261031	261032	261033
Model #	PESPL-60-3032	PESPL-68-3032	PESPL-80-3032	PESFL-56-30S	PESFL-64-30S	PESFL-76-30S
Capacity	1,000 lbs	1,000 lbs	1,000 lbs	1,000 lbs	1,000 lbs	1,000 lbs
Platform or Fork W x L	Platform 32" x 30"	Platform 32" x 30"	Platform 32" x 30"	Fork 3" x 30"	Fork 3" x 30"	Fork 3" x 30"
Lift Height	60"	68"	80"	56"	64"	76"
Leg ID/OD	25.5" / 32"	25.5" / 32"	25.5" / 32"	25.5"/32"	25.5"/32"	25.5"/32"
Wheel:						
Front	5" rigid	5" rigid	5" rigid	5" phenolic	5" phenolic	5" phenolic
Rear	4" swivel	4" swivel	4" swivel	4" swivel	4" swivel	4" swivel
Load Center	18"	18"	18"	18"	18"	18"
Weight	404 lbs	427 lbs	452 lbs	442 lbs	456 lbs	465 lbs
Low Profile Option	Yes	Yes	Yes	No	No	No

Low Profile Outrigger Option

- Available only on fixed base, platform, fork, hydraulic or winch 1,000 lb. capacity stackers.
- Standard stacker outrigger height - 5 1/2".
- Optional low profile height - 2 1/2".
- To order add "LP" to stacker Part #.
Example: 260032-LP.

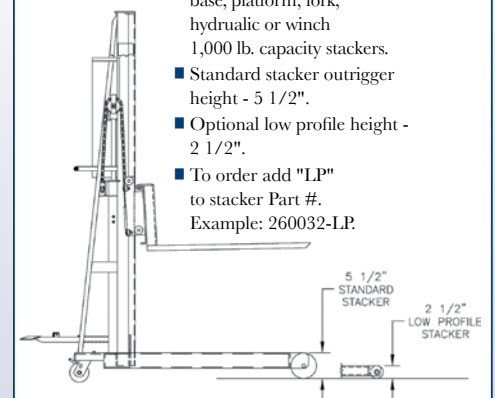

A 5 Year Guarantee Against Weld Failure. A Wesco Quality Exclusive.



Wesco® 1,500 and 2,000 lb Capacity Powered Telescoping Fork Stackers

- **1-year warranty.**
- **Proven quality: WESCO manufactured Hydraulic Cylinder.**
- **Meets ANSI B56.10 specifications.**
- **Adjustable forks.**
- Battery and charger included.
- Forks lower to floor on all models.
- Instant carriage stop for accuracy - no drifting.
- Heavy duty rigid frame and base.
- Double chain lift for better balance and load support.
- Heavy-duty pump.
- Ergonomic "D" handles.
- High strength mast for increased stability.
- Optional 5th wheel for easier overall mobility and turning in confined areas.
- **Power Drive Option NOT available on any telescoping stacker.**
- **SPECIAL ORDER: 110V AC available on 1,500 lb. capacity models only.**

■ To order add AC to the end of the battery powered stacker part #.

Example:

Battery Powered - **#261118**
110V AC Powered - **#261118AC**



Easily adjustable width legs



Adjustable Forks

261118
Shown with 261099
5th Wheel Option

OVERALL DIMENSIONS

w:	48.5"	48.5"	48.5"	48.5"
h:	70.5"	87.5"	70.5"	87.5"
d:	68"	68"	68"	68"

Telescoping Models – Fixed Width Base – 2,000 Lb Capacity

OVERALL DIMENSIONS

w:	57"	57"	57"	57"
h:	70.5"	87.5"	70.5"	87.5"
d:	68"	68"	68"	68"

Telescoping Models – Adjustable Width Base - 1,500 And 2,000 Lb Capacity

Part #	261120	261119	261124	261123	261117	261118	261115	261116
Model #	PTSFL-96-42-42S-2K	PTSFL-130-42-42S-2K	PTSFL-96-42-50S-2K	PTSFL-130-42-50S-2K	PTASFL-96-42-3550S-1.5K	PTASFL-130-42-3550S-1.5K	PTASFL-96-42-3550S-2K	PTASFL-130-42-3550S-2K
Capacity	2,000 lbs	2,000 lbs	2,000 lbs	2,000 lbs	1,500 lbs	1,500 lbs	2,000 lbs	2,000 lbs
Lift Range	1.5"-96"	1.5"-130"	1.5"-96"	1.5"-130"	1.5"-96"	1.5"-130"	1.5"-96"	1.5"-130"
Leg ID/OD	42"/48"	42"/48"	50"/56"	50"/56"	35"-50" ID Adj.	35"-50" ID Adj.	35"-50" ID Adj.	35"-50" ID Adj.
Fork Size D x W x L	1.5" x 3" x 42"	1.5" x 3" x 42"	1.5" x 3" x 42"	1.5" x 3" x 42"	1.5" x 3" x 42"	1.5" x 3" x 42"	1.5" x 3" x 42"	1.5" x 3" x 42"
Outside Fork Spread	7.4" to 30"	7.4" to 30"	7.4" to 30"	7.4" to 30"	7.4" to 30"	7.4" to 30"	7.4" to 30"	7.4" to 30"
Load Center	24"	24"	24"	24"	24"	24"	24"	24"
Weight	995 lbs	1,240 lbs	1,210 lbs	1,240 lbs	1,125 lbs	1,280 lbs	1,125 lbs	1,285 lbs



5th Wheel Steering Option for easier mobility and precision steering in confined areas. Available only on 1,500 and 2,000 lb models. 8" locking polyurethane wheels. Spring loaded handle. Turning radius: 73.5". Can be field installed. Order as separate option under Part # 261099

LIFT EQUIPMENT



1,500-2,000 LB. POWER LIFT FORK STACKERS

*A 5 Year Guarantee Against Weld Failure.
A Wesco Quality Exclusive.*

1,500 & 2,000 lb Capacity Powered Stackers - Fork Models

- 1-year warranty.
- Proven quality: WESCO manufactured Hydraulic Cylinder.
- Meets ANSI B56.10 specifications.
- Battery and charger included.

- Adjustable forks:
 - Lower to floor on all models.
 - 3" wide x 25", 30" and 42" long.
 - OD adjustment from 6" to 24.5" or 29" maximum width.
- Adjustable base legs available on fork models.
- Reinforced frame and base.
- Double chain, lift support.
- Heavy-duty pump.
- Ergonomic "D" handles.
- 5th wheel option see page 65.

- Power Drive Option available: see **page 67** for details. Add "-PD" to end of Part #.
- **SPECIAL ORDER: 110V AC available on 1,500 lb. capacity models only.**

■ To order add AC to the end of the battery powered stacker part #.

Example:

Battery Powered - **#261079**
 110V AC Powered - **#261079AC**
 #261055-PD with Power Drive Option



5.875" ↑↓

261053



30 Fixed and 6 Adjustable Base Leg Fork Models

Part #	Model #	Lift Height	Overall Height	Weight lbs	Capacity lbs	Load Center	Fork Width/Length	Base Leg ID/OD	Adj. Fork Min./Max. OD
261079	PSFL-56-25-15S-1.5K	56"	72"	512	1,500	15"	3"/25"	15"/21"	6" / 24.5"
261080	PSFL-64-25-15S-1.5K	64"	83"	532	1,500	15"	3"/25"	15"/21"	6" / 24.5"
261081	PSFL-76-25-15S-1.5K	76"	94"	596	1,500	15"	3"/25"	15"/21"	6" / 24.5"
261082	PSFL-86-25-15S-1.5K	86"	104"	642	1,500	15"	3"/25"	15"/21"	6" / 24.5"
261083	PSFL-56-25-20S-1.5K	56"	72"	523	1,500	15"	3"/25"	20"/26"	6" / 24.5"
261084	PSFL-64-25-20S-1.5K	64"	83"	543	1,500	15"	3"/25"	20"/26"	6" / 24.5"
261085	PSFL-76-25-20S-1.5K	76"	94"	607	1,500	15"	3"/25"	20"/26"	6" / 24.5"
261086	PSFL-86-25-20S-1.5K	86"	104"	654	1,500	15"	3"/25"	20"/26"	6" / 24.5"
261092	PSFL-56-25-20S-2K	56"	72"	523	2,000	15"	3"/25"	20"/26"	6" / 24.5"
261093	PSFL-64-25-20S-2K	64"	83"	558	2,000	15"	3"/25"	20"/26"	6" / 24.5"
261094	PSFL-76-25-20S-2K	76"	94"	611	2,000	15"	3"/25"	20"/26"	6" / 24.5"
261095	PSFL-86-25-20S-2K	86"	104"	659	2,000	15"	3"/25"	20"/26"	6" / 24.5"
261059	PSFL-64-30-30S-1.5K	64"	83"	566	1,500	18"	3"/30"	30"/36"	6" / 29"
261060	PSFL-76-30-30S-1.5K	76"	94"	630	1,500	18"	3"/30"	30"/36"	6" / 29"
261061	PSFL-86-30-30S-1.5K	86"	104"	677	1,500	18"	3"/30"	30"/36"	6" / 29"
261044	PSFL-64-30-30S-2K	64"	83"	571	2,000	18"	3"/30"	30"/36"	6" / 29"
261045	PSFL-76-30-30S-2K	76"	94"	635	2,000	18"	3"/30"	30"/36"	6" / 29"
261046	PSFL-86-30-30S-2K	86"	104"	682	2,000	18"	3"/30"	30"/36"	6" / 29"
261062	PSFL-64-42-42S-1.5K	64"	83"	571	1,500	24"	3"/42"	42"/48"	6" / 29"
261063	PSFL-76-42-42S-1.5K	76"	94"	637	1,500	24"	3"/42"	42"/48"	6" / 29"
261064	PSFL-86-42-42S-1.5K	86"	104"	688	1,500	24"	3"/42"	42"/48"	6" / 29"
261047	PSFL-64-42-42S-2K	64"	83"	577	2,000	24"	3"/42"	42"/48"	6" / 29"
261048	PSFL-76-42-42S-2K	76"	94"	642	2,000	24"	3"/42"	42"/48"	6" / 29"
261049	PSFL-86-42-42S-2K	86"	104"	693	2,000	24"	3"/42"	42"/48"	6" / 29"
261065	PSFL-64-42-50S-1.5K	64"	83"	577	1,500	24"	3"/42"	50"/56"	6" / 29"
261066	PSFL-76-42-50S-1.5K	76"	94"	642	1,500	24"	3"/42"	50"/56"	6" / 29"
261067	PSFL-86-42-50S-1.5K	86"	104"	693	1,500	24"	3"/42"	50"/56"	6" / 29"
261050	PSFL-64-42-50S-2K	64"	83"	582	2,000	24"	3"/42"	50"/56"	6" / 29"
261051	PSFL-76-42-50S-2K	76"	94"	647	2,000	24"	3"/42"	50"/56"	6" / 29"
261052	PSFL-86-42-50S-2K	86"	104"	698	2,000	24"	3"/42"	50"/56"	6" / 29"
261068	PASFL-64-42-3550S-1.5K	64"	83"	587	1,500	24"	3"/42"	35"-50" ID ADJ.	6" / 29"
261069	PASFL-76-42-3550S-1.5K	76"	94"	652	1,500	24"	3"/42"	35"-50" ID ADJ.	6" / 29"
261070	PASFL-86-42-3550S-1.5K	86"	104"	703	1,500	24"	3"/42"	35"-50" ID ADJ.	6" / 29"
261053	PASFL-64-42-3550S-2K	64"	83"	592	2,000	24"	3"/42"	35"-50" ID ADJ.	6" / 29"
261054	PASFL-76-42-3550S-2K	76"	94"	657	2,000	24"	3"/42"	35"-50" ID ADJ.	6" / 29"
261055	PASFL-86-42-3550S-2K	86"	104"	708	2,000	24"	3"/42"	35"-50" ID ADJ.	6" / 29"

Adjustable Width Legs
6 Models



SINCE 1948



1,500 & 2,000 lb Capacity Powered Stackers - Platform Models

- 1-year warranty.
- Proven quality: WESCO manufactured Hydraulic Cylinder.
- Meets ANSI B56.10 specifications.
- Battery and charger included.
- Platform models lowered height 6".
- Adjustable base legs available on fork models only.
- Fixed platforms 24" x 24", 24" x 27", 30" x 32".
- Reinforced frame and base.
- Double chain, lift support.
- Dual platform stacker #262056, call for details.
- Heavy-duty pump.
- Ergonomic "D" handles.
- 5th wheel option see page 65.
- Power Drive Option available: see below for details. Add "-PD" to end of Part #.
- To order add AC to the end of the battery powered stacker part #.

Example:

Battery Powered 110V AC Powered
 #261074 #261074AC
 #261087-PD with Power Drive Option

- **SPECIAL ORDER: 110V AC available on 1,500 lb. capacity models only.**

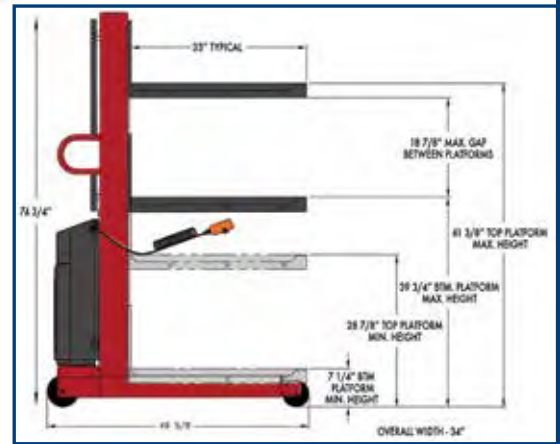

Fixed Base Leg Platform Models

Part #	Model #	Lift Height	Overall Height	Weight lbs	Capacity lbs	Load Center	Platform Width/Length	Base Leg ID/OD
261074	PSPL-60-2424-15S-1.5K	60"	72"	468	1,500	15"	24" x 24"	15"/21"
261075	PSPL-68-2424-15S-1.5K	68"	83"	482	1,500	15"	24" x 24"	15"/21"
261076	PSPL-80-2424-15S-1.5K	80"	94"	523	1,500	15"	24" x 24"	15"/21"
261077	PSPL-90-2424-15S-1.5K	90"	104"	563	1,500	15"	24" x 24"	15"/21"
261088	PSPL-60-2427-20S-2K	60"	72"	476	2,000	15"	27" x 24"	20"/26"
261089	PSPL-68-2427-20S-2K	68"	83"	487	2,000	15"	27" x 24"	20"/26"
261090	PSPL-80-2427-20S-2K	80"	94"	530	2,000	15"	27" x 24"	20"/26"
261091	PSPL-90-2427-20S-2K	90"	104"	569	2,000	15"	27" x 24"	20"/26"
261071	PSPL-60-3032-30S-1.5K	60"	72"	479	1,500	18"	32" x 30"	30"/36"
261072	PSPL-68-3032-30S-1.5K	68"	83"	492	1,500	18"	32" x 30"	30"/36"
261073	PSPL-80-3032-30S-1.5K	80"	94"	534	1,500	18"	32" x 30"	30"/36"
261078	PSPL-90-3032-30S-1.5K	90"	104"	573	1,500	18"	32" x 30"	30"/36"
261056	PSPL-60-3032-30S-2K	60"	72"	484	2,000	18"	32" x 30"	30"/36"
261057	PSPL-68-3032-30S-2K	68"	83"	497	2,000	18"	32" x 30"	30"/36"
261058	PSPL-80-3032-30S-2K	80"	94"	539	2,000	18"	32" x 30"	30"/36"
261087	PSPL-90-3032-30S-2K	90"	104"	578	2,000	18"	32" x 30"	30"/36"
262056	PDPL-61-3033-30S-2K	61.375"	74.75"	674	2,000	18.25"	33" x 30"	30"/36"



Model #
 PSFL-86-25-20S-2K-PD
 2,000 lb. capacity and
 86" lift height



Easy fingertip controls.



High torque motor drive.

Optional Power Drive System for Fork and Platform Stackers

- Variable speed, steerable power drive system allows a single user to easily control forward and reverse movement of stacker.
- Simple to use finger-tip controls are built into steering handle.
- 180° hinged design allows precision steering in confined spaces.
- Spring-loaded mechanism automatically compensates for uneven floors ensuring drive wheels maintain constant contact with floor.
- Two maintenance-free sealed batteries provide plenty of power for propulsion and lift.
- 1,000 - 2,000 lb. capacities.
- Automatic emergency safety switch instantly reverses direction if control post comes in contact with obstacle.



Model #
 PESPL-80-2424-PD
 1,000 lb. capacity
 platform model with
 80" lift height



Model # PCBFL-64-25-PD
 1,000 lb. capacity
 counter-balance model

Battery Powered System provides both propulsion and lift!
Eliminates the stress and strain of lifting and transporting heavy loads. All Wesco power lift stackers can be ordered as power drive models (except for telescoping models). All other operating specifications are the same as equivalent power lift-only models. To order, simply add "-PD" to the end of the Model #.

EQUIPMENT

Features:

- Capacity ranges from 200 to 6,000 lbs.
- Solid steel top and base construction.
- Casters provide easy mobility.
- Floor locks are standard on all 500 lb.+ capacity tables.



LT-02-1616



LT-10-1836



LT-60-2436

Wesco Standard Duty Tables (200 - 1,000 lb Capacities)

- 1-year warranty.
- LT-02-1616 has four 3" hard rubber swivel casters.
- LT-02-1616 ships via UPS knocked down.
- LT-05 and LT-10 models feature 2 rigid and 2 swivel 4" phenolic resin roller bearing wheel casters.
- 7 Gauge steel top and base.
- 3/8" lift per stroke.

	OVERALL DIMENSIONS			
w:	16"	18"	18"	18"
h:	28.5"	28.5"	30.5"	30.5"
d:	16"	16"	21.25"	39.25"

Wesco Medium & Heavy Duty Tables (2,000-6,000 lb Capacities)

- 1-year warranty.
- LT models feature 2 rigid and 2 swivel 6" phenolic resin roller bearing wheel casters.
- Four support posts and push handle.
- Foot operated floor lock.
- LTL models feature 2 rigid and 2 swivel 4" phenolic resin roller bearing wheel casters.
- Wesco made hydraulic pump with 3/8" lift per stroke.

	OVERALL DIMENSIONS							
w:	24"	32"	24"	32"	24"	32"	24"	32"
h:	30.5"	30.5"	37"	37"	37"	37"	37"	37"
d:	39.25"	51.25"	39.25"	51.25"	39.25"	51.25"	39.25"	51.25"

Part #	260059	260060	260061	260062	260063	260064	260065	260066	260067	260068	260069
Model #	LT-02-1616	LT-05-1818	LT-10-1836	LTL-20-2436	LTL-20-3248	LT-20-2436	LT-20-3248	LT-40-2436	LT-40-3248	LT-60-2436	LT-60-3248
Capacity	200 lbs	500 lbs	1,000 lbs	2,000 lbs	2,000 lbs	2,000 lbs	2,000 lbs	4,000 lbs	4,000 lbs	6,000 lbs	6,000 lbs
Table Size W x L	16" x 16"	18" x 18"	18" x 36"	24" x 36"	32" x 48"	24" x 36"	32" x 48"	24" x 36"	32" x 48"	24" x 36"	32" x 48"
Lowered Height	28.5"	30.5"	30.5"	30.5"	30.5"	37"	37"	37"	37"	37"	37"
Raised Height	46"	47.5"	47.5"	47.5"	47.5"	59"	59"	59"	59"	59"	59"
Caster Size	3"	4"	4"	4"	4"	6"	6"	6"	6"	6"	6"
Support Posts	None	2	2	4	4	4	4	4	4	4	4
Weight	54 lbs	122 lbs	168 lbs	308 lbs	350 lbs	339 lbs	465 lbs	349 lbs	475 lbs	359 lbs	485 lbs

Value Lift Tables

- Polyurethane casters.
- Foot operated pump and release.
- Ships KD.
- 36 pumps to fully raised height.



272469



272470

	OVERALL DIMENSIONS	
w:	16"	18"
h:	29"	30"
d:	16"	18"

Part #	272469	272470
Model #	VLT200	VLT500
Capacity	200 lbs	500 lbs
Table Size	16" x 16"	18" x 18"
Lowered Height	29"	30"
Raised Height	46"	48"
Support Posts	None	Two
Floor Lock (FL)	N/A	Yes
Caster Size	(4) swivel 3"	(2) rigid (2) swivel 4"
Weight	76 lbs	153 lbs

5 Table-Top Options

- Factory installed only.
- Call for price.
- Not available on 16" or 18" wide tables.
- For both manual and powered Wesco-made tables only.
- Table capacity determines option capacity.
- Roller: diameter 1.9" with 7/16" hex axle.
- 1 3/8" diameter ball transfer.
- Push-Pull and Roller Top options have two directions of travel: length or width.
- To order:
 - select table Part No. (manual or powered).
 - select Option and add as suffix to table Part No.
 - Example: 260062-PPL, 24" x 36", 2,000 lb. capacity, manual table with a Push-Pull option that travels the length of the table.



PPL (Push-Pull)

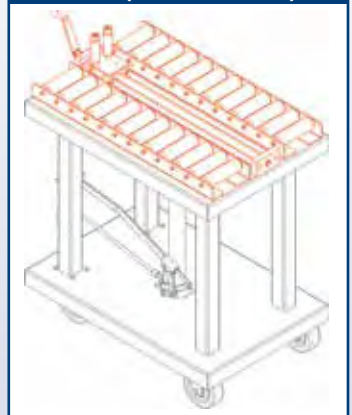

Travel: Length of table

Suffix Code: PPL

Table top to top of roller: 3"

Remote control for raising/lowering. Magnets on back of remote allow for storage anywhere on table.



261102



Powered Lift Tables

- 1-year warranty.
- Up to 6,000 lbs capacity.
- High volume output pump raises 1.5" per second without load.
- Standard floor lock holds table steady for loading and unloading.
- Easy to read illuminated battery status voltmeter.
- With a minimally charged battery, unit can be used while recharging.

Push-pull, roller and ball tops available on Wesco 24" x 36" and 32" x 48" manual and power tables.

Available with Power Drive

- Combines power lift and power drive capabilities.
- Power drive option weighs 160 lbs.
- To order Power Drive, add -PD to the end of Model #.

Example:

Lift Table Power Drive
#PLT-10-1836 #PLT-10-1836-PD



Shown With Power Drive Option - 261105-PD

OVERALL DIMENSIONS

w:	18"	24"	32"	24"	32"	24"	32"	24"	32"
h:	30.5"	30.5"	30.5"	37"	37"	37"	37"	37"	37"
d:	39.25"	39.25"	51.25"	39.25"	51.25"	39.25"	51.25"	39.25"	51.25"

Part #	261108	261100	261101	261102	261103	261104	261105	261106	261107
Model #	PLT-10-1836	PLTL-20-2436	PLTL-20-3248	PLT-20-2436	PLT-20-3248	PLT-40-2436	PLT-40-3248	PLT-60-2436	PLT-60-3248
Capacity	1,000 lbs	2,000 lbs	2,000 lbs	2,000 lbs	2,000 lbs	4,000 lbs	4,000 lbs	6,000 lbs	6,000 lbs
Table Top W x L	18" x 36"	24" x 36"	32" x 48"	24" x 36"	32" x 48"	24" x 36"	32" x 48"	24" x 36"	32" x 48"
Raised Ht	47.5"	47.5"	47.5"	59"	59"	59"	59"	59"	59"
Lowered Ht	30.5"	30.5"	30.5"	37"	37"	37"	37"	37"	37"
Caster Size	4"	4"	4"	6"	6"	6"	6"	6"	6"
Weight	415 lbs	472 lbs	597 lbs	567 lbs	607 lbs	597 lbs	607 lbs	597 lbs	607 lbs

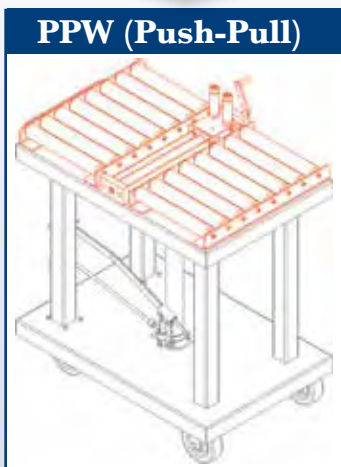

PPW (Push-Pull)

Travel: Width of table
 Suffix Code: PPW
 Table top to top of roller: 3"

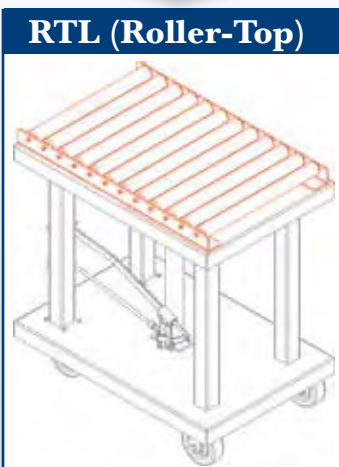

RTL (Roller-Top)

Travel: Length of table
 Suffix Code: RTL
 Table top to top of roller: 3"

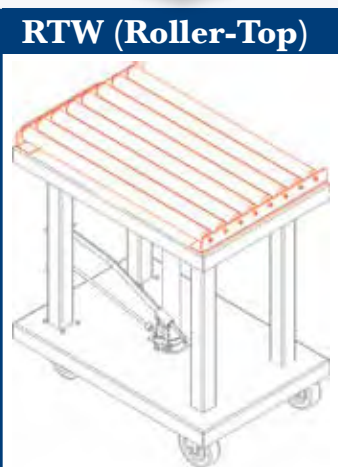

RTW (Roller-Top)

Travel: Width of table
 Suffix Code: RTW
 Table top to top of roller: 3"

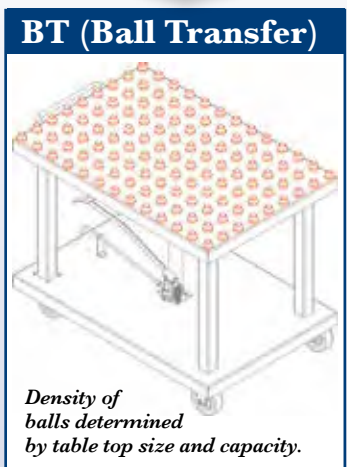

BT (Ball Transfer)

Density of balls determined by table top size and capacity.

1" diameter balls
 Suffix Code: BT
 Table top to top of ball: 1 3/8"



HT-200-FR

Also see Wesco Lift Tables on page 68.



LT-02-1616



LT-05-1818

200 lb. Capacity Foot Operated Hydraulic Lift Table

- 1-year warranty.
- Top and base 1/4" steel.
- Top rotates 360°.
- 4 swivel 2" diameter rubber casters.

300 lb. Capacity Foot Operated Hydraulic Lift Table

- 1-year warranty.
- Top and base 3/8" steel.
- 2 rigid and 2 swivel 3 1/2" diameter rubber casters.
- Optional phenolic resin and polyurethane caster wheels.
- Floor lock.
- Two posts.

Part #	492220	492221	492222	492223	492224	492225	492226	492227	492228
Model #	HT-200-FR	HT-203-FR	HT-201-FR	HT-209-FR	HT-300-FR	HT-318-FR	HT-316-FR	HT-314-FR	HT-312-FR
Capacity	200 lbs	200 lbs	200 lbs	200 lbs	300 lbs	300 lbs	300 lbs	300 lbs	300 lb
Table Size	16" x 16"	16" x 16"	16" x 16"	16" x 16"	18" x 18"	18" x 18"	18" x 18"	18" x 18"	18" x 18"
Lowered Height	26"	24"	22"	20"	30"	28"	26"	24"	22"
Raised Height	44"	40"	36"	32"	48"	46"	42"	38"	34"
Caster Size	2"	2"	2"	2"	3.5"	3.5"	3.5"	3.5"	3.5"
Lift	18"	16"	14"	12"	18"	18"	16"	14"	12"
Weight	53 lbs	52 lbs	51 lbs	50 lbs	135 lbs	131 lbs	128 lbs	124 lbs	121 lbs



400 lb. & 500 lb. Capacity Foot Operated Hydraulic Lift Table

- 1-year warranty.
- Top and base 12 gauge steel.
- 2 rigid and 2 swivel 5" diameter rubber casters.
- Floor lock.
- Optional phenolic resin, polyurethane and steel caster wheels.
- Precision telescoping guide tubes.



HT-500-FR

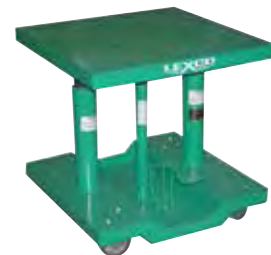

HT-2388-05-FR with Drop-Base

Part #	492229	492230	492231	492232	496037	492234	492235	492236	492237	492238
Model #	HT-400-FR	HT-416-FR	HT-414-FR	HT-412-FR	HT-500-FR	HT-2388-05-FR	HT-2368-05-FR	HT-2346-05-FR	HT-2324-05-FR	HT-2302-05-FR
Capacity	400 lbs	400 lbs	400 lbs	400 lbs	500 lbs	500 lbs	500 lbs	500 lbs	500 lbs	500 lbs
Table Size W x L	18" x 24"	18" x 24"	18" x 24"	18" x 24"	20" x 30"	20" x 30"	20" x 30"	20" x 30"	20" x 30"	20" x 30"
Lowered Height	30"	28"	26"	24"	30"	28"	26"	24"	22"	20"
Raised Height	48"	44"	40"	36"	48"	46"	44"	40"	36"	32"
Caster Size	5"	5"	5"	5"	5"	5"	5"	5"	5"	5"
Lift	18"	16"	14"	12"	18"	18"	18"	16"	14"	12"
Weight	119 lbs	115 lbs	112 lbs	108 lbs	142 lbs	173 lbs	180 lbs	176 lbs	170 lbs	164 lbs
Base	Flat	Flat	Flat	Flat	Flat	Drop	Drop	Drop	Drop	Drop



492204

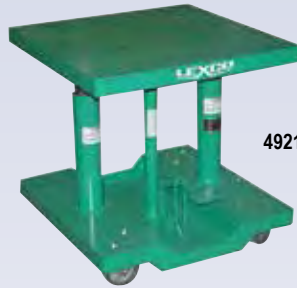

492199



499811
(20" x 30" #492205 Table with #499206 Optional Push-Pull attached.)



2,000 lb. Capacity Foot Operated Hydraulic Lift Table

- **1-year warranty.**
- Precision telescoping guide tubes.
- 1/4" reinforced steel top and base.
- 5" diameter steel caster wheels.
- 2 rigid/2 swivel/1 floor lock on 20" x 30" and 30" x 30" models.
- 4 swivel casters/2 floor locks on 30" x 48" models.
- AC & DC power custom tables available. **Call for details.**
- Compatible with optional Push Pull Conveyor Top.
- **Push Pull Die Conveyor Top may be ordered separately without table or attached to table top at factory.**

Part #	492204	492205	492206	492207	492208	492209
Model #	HT-2338-2F	HT-2388-2F	HT-2368-2F	HT-2346-2F	HT-2324-2F	HT-2302-2F
Capacity	2,000 lbs	2,000 lbs	2,000 lbs	2,000 lbs	2,000 lbs	2,000 lbs
Table Size	20" x 30"	20" x 30"	20" x 30"	20" x 30"	20" x 30"	20" x 30"
Lowered Height	30"	28"	26"	24"	22"	20"
Raised Height	48"	46"	44"	40"	36"	32"
5" Steel Caster	2 rigid/2 swivel	2 rigid/2 swivel	2 rigid/2 swivel	2 rigid/2 swivel	2 rigid/2 swivel	2 rigid/2 swivel
Lift	18"	18"	18"	16"	14"	12"
Weight	215 lbs	216 lbs	224 lbs	220 lbs	213 lbs	208 lbs

↓ TABLE WITH PUSH-PULL ATTACHED AT FACTORY ↓

Part #	499800	499811	499820	499821	499822	499823
Model #	HTP-2338-2F	HTP-2388-2F	HTP-2368-2F	HTP-2346-2F	HTP-2324-2F	HTP-2302-2F
Lowered Height	33"	31"	29"	27"	25"	23"
Raised Height	51"	49"	47"	43"	39"	35"

Part #	492193	492199	492200	492201	492202	492203	492210	492211	492212	492213	492214	492215
Model #	HT-3338-2F	HT-3388-2F	HT-3368-2F	HT-3346-2F	HT-3324-2F	HT-3302-2F	HT-3438-2F	HT-3488-2F	HT-3468-2F	HT-3446-2F	HT-3424-2F	HT-3402-2F
Capacity	2,000 lbs	2,000 lbs	2,000 lbs	2,000 lbs	2,000 lbs	2,000 lbs	2,000 lbs	2,000 lbs	2,000 lbs	2,000 lbs	2,000 lbs	2,000 lbs
Table Size	30" x 30"	30" x 30"	30" x 30"	30" x 30"	30" x 30"	30" x 30"	30" x 48"	30" x 48"	30" x 48"	30" x 48"	30" x 48"	30" x 48"
Lowered Height	30"	28"	26"	24"	22"	20"	30"	28"	26"	24"	22"	20"
Raised Height	48"	46"	44"	40"	36"	32"	48"	46"	44"	40"	36"	32"
5" Steel Caster	2 rigid/2 swivel	2 rigid/2 swivel	2 rigid/2 swivel	2 rigid/2 swivel	2 rigid/2 swivel	2 rigid/2 swivel	2 rigid/2 swivel	2 rigid/2 swivel	2 rigid/2 swivel	2 rigid/2 swivel	2 rigid/2 swivel	2 rigid/2 swivel
Lift	18"	18"	18"	16"	14"	12"	18"	18"	18"	16"	14"	12"
Weight	276 lbs	274 lbs	284 lbs	280 lbs	274 lbs	268 lbs	460 lbs	472 lbs	482 lbs	478 lbs	472 lbs	466 lbs

↓ TABLE WITH PUSH-PULL ATTACHED AT FACTORY ↓

Part #	499824	499825	499826	499827	499828	499829	499830	499831	499832	499833	499834	499835
Model #	HTP-3338-2F	HTP-3388-2F	HTP-3368-2F	HTP-3346-2F	HTP-3324-2F	HTP-3302-2F	HTP-3438-2F	HTP-3488-2F	HTP-3468-2F	HTP-3446-2F	HTP-3424-2F	HTP-3402-2F
Lowered Height	33"	31"	29"	27"	25"	23"	33"	31"	29"	27"	25"	23"
Raised Height	51"	49"	47"	43"	39"	35"	51"	49"	47"	43"	39"	35"

Optional Manual Push-Pull Conveyor Tops (Top only/without table.)

- **Optional top only, mounted on 1/4" steel plate. Table not included.**
- **1-year warranty.**
- Easier method for pushing and pulling loads to and from the unit.

- 5-lb. effort required to crank the handle.
- Sold as stand alone unit or assembled onto table.
- **Fits only 2,000 lb Lexco Model HT Lift Tables.**
- Fits 3 sizes of table tops: 20" x 30", 30" x 30" and 30" x 48" only.
- Drilling and layout required if purchased without table.

Part #	499206	499235	499237
Model #	1098	1106	SP-5746
Capacity	2,000 lbs	2,000 lbs	2,000 lbs
Fits Table Top W x L	20" x 30"	30" x 30"	30" x 48"
Max. Die Size W x L	20" x 23"	30" x 23"	30" x 41"
Direction of Travel	30"	30"	48"
Weight	123 lbs	143 lbs	225 lb



Photo illustrates Optional #499206 Push-Pull top. TABLE NOT INCLUDED.

EQUIPMENT

LEXCO HYDRAULIC PRECISION LIFT TABLES

3,000 - 6,000 lb. Foot Operated or Powered Portable Hydraulic Lift Tables

- **1-year warranty.**
- AC and DC power options available.
- 1/4" steel top and base.
- 2 rigid and 2 swivel steel wheel casters.
- Standard designs available in 2 sizes: 30" x 30" and 48" x 30".
- Available in 4 capacities: 3,000 4,000 5,000 and 6,000.
- Precision telescoping guide tubes.
- Stabilizers included on 4,000, 5,000 and 6,000 models.



HT-3043-23

30" x 30" Tables

Part #	496043	496044	496045	496046	496047	496048	496049	496050	496051	496038
Model #	HT-3033-23	HT-3033-22	HT-3033-20	HT-3033-18	HT-3033-16	HT-3034-23	HT-3034-22	HT-3034-20	HT-3034-18	HT-3034-16
Capacity	3,000 lbs	3,000 lbs	3,000 lbs	3,000 lbs	3,000 lbs	4,000 lbs	4,000 lbs	4,000 lbs	4,000 lbs	4,000 lbs
Table Size	30" x 30"	30" x 30"	30" x 30"	30" x 30"	30" x 30"	30" x 30"	30" x 30"	30" x 30"	30" x 30"	30" x 30"
Raised Height	54"	52"	48"	44"	40"	54"	52"	48"	44"	40"
Lowered Height	31"	30"	28"	26"	24"	31"	30"	28"	26"	24"
Casters	6"	6"	6"	6"	6"	6"	6"	6"	6"	6"
Weight - Foot Pedal	437 lbs	433 lbs	423 lbs	413 lbs	402 lbs	448 lbs	444 lbs	433 lbs	423 lbs	407 lbs
Weight - Electric	488 lbs	484 lbs	474 lbs	464 lbs	498 lbs	499 lbs	495 lbs	484 lbs	474 lbs	458 lbs

Part #	496052	496053	496054	496055	496056	496057	496058	496059	496060	496061
Model #	HT-3035-23	HT-3035-22	HT-3035-20	HT-3035-18	HT-3035-16	HT-3036-23	HT-3036-22	HT-3036-20	HT-3036-18	HT-3036-16
Capacity	5,000 lbs	5,000 lbs	5,000 lbs	5,000 lbs	5,000 lbs	6,000 lbs	6,000 lbs	6,000 lbs	6,000 lbs	6,000 lbs
Table Size	30" x 30"	30" x 30"	30" x 30"	30" x 30"	30" x 30"	30" x 30"	30" x 30"	30" x 30"	30" x 30"	30" x 30"
Raised Height	54"	52"	48"	44"	40"	54"	52"	48"	44"	40"
Lowered Height	31"	30"	28"	26"	24"	31"	30"	28"	26"	24"
Casters	6"	6"	6"	6"	6"	6"	6"	6"	6"	6"
Weight - Foot Pedal	476 lbs	472 lbs	461 lbs	451 lbs	435 lbs	480 lbs	476 lbs	465 lbs	454 lbs	437 lbs
Weight - Electric	527 lbs	523 lbs	512 lbs	502 lbs	486 lbs	531 lbs	527 lbs	516 lbs	505 lbs	488 lbs

48" x 30" Tables

Part #	496062	496063	496064	496065	496066	496067	496068	496069	496070	496071
Model #	HT-3043-23	HT-3043-22	HT-3043-20	HT-3043-18	HT-3043-16	HT-3044-23	HT-3044-22	HT-3044-20	HT-3044-18	HT-3044-16
Capacity	3,000 lbs	3,000 lbs	3,000 lbs	3,000 lbs	3,000 lbs	4,000 lbs	4,000 lbs	4,000 lbs	4,000 lbs	4,000 lbs
Table Size	48" x 30"	48" x 30"	48" x 30"	48" x 30"	48" x 30"	48" x 30"	48" x 30"	48" x 30"	48" x 30"	48" x 30"
Raised Height	54"	52"	48"	44"	40"	54"	52"	48"	44"	40"
Lowered Height	31"	30"	28"	26"	24"	31"	30"	28"	26"	24"
Casters	6"	6"	6"	6"	6"	6"	6"	6"	6"	6"
Weight - Foot Pedal	555 lbs	551 lbs	540 lbs	530 lbs	520 lbs	568 lbs	563 lbs	553 lbs	543 lbs	526 lbs
Weight - Electric	606 lbs	602 lbs	591 lbs	581 lbs	571 lbs	619 lbs	614 lbs	604 lbs	594 lbs	577 lbs

Part #	496072	496073	496074	496075	496076	496077	496078	496079	496080	496081
Model #	HT-3045-23	HT-3045-22	HT-3045-20	HT-3045-18	HT-3045-16	HT-3046-23	HT-3046-22	HT-3046-20	HT-3046-18	HT-3046-16
Capacity	5,000 lbs	5,000 lbs	5,000 lbs	5,000 lbs	5,000 lbs	6,000 lbs	6,000 lbs	6,000 lbs	6,000 lbs	6,000 lbs
Table Size	48" x 30"	48" x 30"	48" x 30"	48" x 30"	48" x 30"	48" x 30"	48" x 30"	48" x 30"	48" x 30"	48" x 30"
Raised Height	54"	52"	48"	44"	40"	54"	52"	48"	44"	40"
Lowered Height	31"	30"	28"	26"	24"	31"	30"	28"	26"	24"
Casters	6"	6"	6"	6"	6"	6"	6"	6"	6"	6"
Weight - Foot Pedal	600 lbs	596 lbs	585 lbs	575 lbs	559 lbs	604 lbs	600 lbs	589 lbs	578 lbs	562 lbs
Weight - Electric	651 lbs	647 lbs	636 lbs	626 lbs	610 lbs	655 lbs	651 lbs	640 lbs	629 lbs	613 lbs

Other sizes also available. Call for details.

- 30" wide x 60", 72", 96" and 120" long.
- 36" wide x 60", 72", 96" and 120" long.
- 48" wide x 60", 72", 96" and 120" long.
- These sizes with 2 rigid and 2 swivel 8" diameter steel wheel casters and two floor locks.



SINCE 1948

2,000 lb. Capacity Long-Deck Hydraulic Foot-Operated Lift Tables

- 1-year warranty.
- AC and DC power options available.
- Standard lift height 30" - 48".
- Optional lift ranges available, call factory.
- 10 gauge steel top.



- Foot operated.
- Precision telescoping guide tubes.
- 4 swivel 5" diameter steel wheels or optional polyurethane wheels.
- 2 floor locks.

Call for information on powered models.

Part #	492239	492240	492241	492242	492128	492129	492130	492131
Model #	STN-2005-2F	STN-2006-2F	STN-2008-2F	STN-2010-2F	STN-3005-2F	STN-3006-2F	STN-3008-2F	STN-3010-2F
Capacity	2,000 lbs	2,000 lbs	2,000 lbs	2,000 lbs	2,000 lbs	2,000 lbs	2,000 lbs	2,000 lbs
Table Size	5' x 20"	6' x 20"	8' x 20"	10' x 20"	5' x 30"	6' x 30"	8' x 30"	10' x 30"
Raised Height	48"	48"	48"	48"	48"	48"	48"	48"
Lowered Height	30"	30"	30"	30"	30"	30"	30"	30"
Casters	5"	5"	5"	5"	5"	5"	5"	5"
Weight	384 lbs	400 lbs	459 lbs	505 lbs	423 lbs	457 lbs	512 lbs	568 lbs

Call for information on powered models.

3,000 & 5,000 lb. Capacity Long-Deck Hydraulic Foot-Operated Lift Tables

- 1-year warranty.
- AC and DC power options available.
- Load stabilizer assembly on 5,000 lb models.
- 2 floor locks.
- Precision telescoping guide tubes.
- Table top 3,000 lb. models: .25" thick steel.
- Table top 5,000 lb. models: .25" thick steel.



STN-3608-5F
With Load Stabilizer

Part #	492250	492251	492252	492253	492254	492255	492256	492257
Model #	STN-3605-3F	STN-3606-3F	STN-3608-3F	STN-3610-3F	STN-3605-5F	STN-3606-5F	STN-3608-5F	STN-3610-5F
Capacity	3,000 lbs	3,000 lbs	3,000 lbs	3,000 lbs	5,000 lbs	5,000 lbs	5,000 lbs	5,000 lbs
Table Size	5' x 36"	6' x 36"	8' x 36"	10' x 36"	5' x 36"	6' x 36"	8' x 36"	10' x 36"
Raised Height	56.375"	56.375"	56.375"	56.375"	53.125"	53.125"	53.125"	53.125"
Lowered Height	36.375"	36.375"	36.375"	36.375"	33.125"	33.125"	33.125"	33.125"
Casters	8" steel wheels 4 / swivel	8" steel wheels 4 / swivel	8" steel wheels 4 / swivel	8" steel wheels 4 / swivel	8" steel wheels 2 swivel & brake 2 rigid	8" steel wheels 2 swivel & brake 2 rigid	8" steel wheels 2 swivel & brake 2 rigid	8" steel wheels 2 swivel & brake 2 rigid
Weight	811 lbs	846 lbs	954 lbs	1,026 lbs	1,010 lbs	1,074 lbs	1,397 lbs	1,486 lbs



Call for information on powered models.

Model DH-3005-43

The DH series hydraulic die handler is a cost effective mobile die cart that allows you to transport, separate, and present your dies for service and maintenance.

2,000, 3,000 & 4,000 lb. Capacity Die Handlers

- 1-year warranty.
- Heavy-duty steel adjustable clamps for gripping the upper die set for separation.
- Floor lock.
- Precision telescoping guide tubes.
- Rigid die hangers with 360° indexing plate.
- Optional gantry heights available upon request.

Part #	499243	499244	499245	499246
Model #	DH-3339-22	DH-3438-24	DH-3043-22	DH-3005-43
Capacity	2,000lbs	2,000lbs	3,000 lbs	4,000 lbs
Table Top W x L	30" x 30"	30" x 48"	30" x 48"	30" x 60"
Raised Height	48"	48"	52"	55"
Lowered Height	30"	30"	30"	32"
Minimum Clearance under Bar to Table Top	19.885"	19.885"	20.5"	20.5"
Caster Size/ Type	5" / 2 swivel / 2 rigid	5" / 4 swivel	6" / 4 swivel	8" / 2 swivel / 2 rigid
Max. Die Size	30" x 24"	42" x 30"	42" x 30"	54" x 30"
Weight	388 lbs	590 lbs	747 lbs	1,069 lbs



LT-330SL

Folding Handle Scissors Lift Table

- Folding handle lays flat on table top.
- Chrome plated handle and foot pedal.
- Lever release handle.
- Moldon polyurethane wheels and locking swivel casters.
- Foot operated pump.

OVERALL DIMENSIONS

w: 17.75"	20"	19.5"	20"
h: 37"	39"	39"	39"
d: 36"	37"	42"	37"



LT-700SL



Fixed Handle Scissors Tables

- Fixed handle.
- Foot operated pump.
- Easy to use spring loaded release lever.
- 5" x 1.5" moldon polyurethane wheels and locking casters.

OVERALL DIMENSIONS

w: 19.5"	19.5"
h: 37"	37"
d: 42"	42"



LT-770DSL



Double Scissors High Lift Tables

- Fixed handle.
- Chrome plated handle and foot pedal.
- Lever release handle.
- 5" x 1.5" moldon polyurethane wheels and locking swivel casters.
- Foot operated pump.

OVERALL DIMENSIONS

w: 19.5"	24"
h: 37"	37"
d: 45.5"	58"



LT-2200SL



LT-1650SL

Heavy Duty Scissors Lift Tables

- Fixed handle.
- Chrome plated handle and foot pedal.
- 5" x 2" moldon polyurethane wheels and locking swivel casters.
- Foot operated pump.

OVERALL DIMENSIONS

w: 20"	20"
h: 39.5"	39.5"
d: 49"	50"

Part #	260201	260207	272974	260208	260199	260200	260204	272862	272970	272973
Model #	LT-330SL	SLT-660-11	LT-660FHSL	SLT-1100-11	LT-700SL	LT-1000SL	LT-770DSL	LT-1540DSL	LT-1650SL	LT-2200SL
Capacity	330 lbs	660 lbs	660 lbs	1,100 lbs	700 lbs	1,000 lbs	770 lbs	1,540 lbs	1,650 lbs	2,200 lbs
Table Size	17.75" x 27.5"	20" x 32"	19.5" x 32"	20" x 32"	19.5" x 32"	19.5" x 32"	19.5" x 35.5"	24" x 48"	20" x 39"	20" x 40"
Raised Height	28.5"	35"	35"	35"	35"	35"	51"	59"	35.5"	39"
Lowered Height	8.5"	11"	14"	11"	14"	14"	14"	17.75"	16.5"	15"
Caster Size	4" x 1"	5" x 1.5"	5" x 1.5"	5" x 1.5"	5" x 1.5"	5" x 1.5"	5" x 1.5"	5" x 1.5"	5" x 2"	5" x 2"
Locking Caster (LC)	LC	LC	LC	LC	LC	LC	LC	LC	LC	LC
Weight	98 lbs	165 lbs	170 lbs	187 lbs	170 lbs	185 lbs	227 lbs	430 lbs	276 lbs	269 lbs

TABLE TOP SIZES

32" WIDE X 63" LONG
30" WIDE X 80" LONG



273261



Manually operated safety bars lock table in raised position.

Long Deck Scissors Table

- Oversized **63" long** x 32" wide and **80" long** x 30" wide table tops accommodate large cargo.
- Two wheels and two locking swivel casters.
- Handle height - 38" (32" x 63" table) 39" (30" x 80" table).
- Hydraulic foot pump.
- Safety bars.
- Table top thickness: .125" (3mm).

OVERALL DIMENSIONS

w: 32"	34.5"
h: 38"	53.5"
d: 74.25"	80.125"



273269



Scissors Table with Roller Top

- Roller top permits easy movement of cargo for loading and unloading.
- Two locking swivel casters - 5" x 1½" moldon polyurethane.
- Two 5" x 1½" moldon polyurethane casters.
- Handle height - 38¼".
- Two dual-position end stops help keep cargo in place.
- Eight 2" diameter rollers 18½" long.
- Hydraulic foot pump.
- Variable lowering speed valve.

OVERALL DIMENSIONS

w: 20.25"
h: 38.25"
d: 43"



273265

Hydraulic Die Lift Table

- Table top size - 24" x 36".
- Handle height - 36.75".
- Two swivel locking casters - 5" x 1½" moldon polyurethane.
- Hydraulic foot pump.
- Removable handle - may also be reversed for use in confined areas.
- Variable lowering speed.

OVERALL DIMENSIONS

w: 24"
h: 36.75"
d: 49.5"

Part #	273261	273230	273269	273265
Model #	LDT-3263	LDT-3080	DRT-2033	DT-2436
Capacity	1,100 lbs	2,200 lbs	660 lbs	2,000 lbs
Table Size	32" x 63"	30" x 80"	19.5" x 32.5"	24" x 36"
Raised Height	36"	53.5"	38.25"	36"
Lowered Height	11.25"	14.2"	12.5"	24.25"
Caster Size/Type	5" x 1.5" Moldon Polyurethane	Nylon 3" x 1.5" swivel 7" x 2" wheel	5" x 1.5"	5" x 1.5"
Weight	340 lbs	440 lbs	210 lbs	265 lbs



273710



273713



273711



273712



270662



Powered Lift Scissors Table

- 12 volt rechargeable, deep cycle batteries with onboard charger and battery gauge.
- Moldon polyurethane wheels and locking swivel casters.
- Chrome plated handle.
- Keyed on/off switch.
- Raised-height limit switch.
- Push-button pendant can be removed for hand held operation.
- Overload bypass valve.
- Emergency stop button.

OVERALL DIMENSIONS

w: 19.75"	20.5"	24.5"	19.625"
h: 36"	38"	36.25"	36"
d: 45.25"	52"	53.75"	47.75"

Mini Electric Lift Table

- Heavy duty to handle tough loads.
- Small and light enough to move.
- Full perimeter safety bar stops table from lowering if it contacts an obstruction.
- 110V 60 Hz.
- Push button station.

OVERALL DIMENSIONS

w: 24"
h: 30"
d: 35"

Part #	273710	273711	273712	273713	270662
Model #	PSLT-660	PSLT-1100	PSLT-1650	PSLT-770-DS	MELT
Capacity	660 lbs	1,100 lbs	1,650 lbs	770 lbs (Double Scissors)	2,200 lbs
Table Size W x L	19.75" x 33.5" x 2"	20.5" x 39.75" x 2.25"	20" x 39.5" x 2.25"	19.625" x 35.875" x 2.25"	24" x 35"
Raised Height	34.25"	40.5"	39.5"	51.5"	30"
Lowered Height	11.25"	17.25"	17"	14.5"	7"
Caster Size	5" x 1.25"	6" x 1.5"	6" x 2"	5" x 1.25"	N/A
Qty. of batteries	4	2	4	4	N/A
Weight	256 lbs	346 lbs	353 lbs	300 lbs	283 lbs



272986



Protective Skirt - Part # 275001

- Option must be ordered as a separate item.
- Only available as factory installed.
- Fits both spring and pneumatic pallet levelers.

Pallet Leveler

- The pallet leveler progressively lowers as pallet is loaded and raises as pallet is unloaded.
- 3 Heavy duty calibrated springs used in combination according to desired load range.
- Bearing supported carousel for easy turning.
- Built in fork pockets for ease of transport.
- Helps reduce fatigue and injury from bending and lifting.

OVERALL DIMENSIONS

w: 36"
h: 9.25" Compressed / 29" Raised
d: 45.5"



272696

Pneumatic Pallet Leveler

- The pneumatic pallet leveler progressively lowers as pallet is loaded and raises as pallet is unloaded.
- Pneumatic bellows actuates raising and lowering of loads.
- 80 PSI of initial air pressure required.
- Air tank and controls are self-contained and do not require constant air pressure.
- Removable tank and controls for remote operation; 48" of hose included.

OVERALL DIMENSIONS

w: 36"
h: 12.55" Compressed / 28.5" Raised
d: 45.5"

Part #	272986	272696
Model #	PL	PPL
Capacity	400-4,500 lbs	4,500 lb maximum
Raised Height	29"	28.5" (without load)
Lowered Height	9.25"	12.5"
Carousel Diameter	40.75"	40.75"
Rotating Ring Diameter	43.5"	43.5"
Fork Pocket L x W	39" x 5.75"	39" x 5.75"
Load Size	72" x 50" x 50"	72" x 50" x 50"
Weight	352 lbs	322 lbs

WESCO® RAIS-N-ROL™ MACHINERY MOVERS

A 5 Year Guarantee Against Weld Failure. A Wesco Quality Exclusive.

Features:

- Heavy duty capacities up to 5 tons - the most economical way to lift and move large bulky loads.
- Swivel casters allow movement in any direction.
- Hand operated hydraulic jack for easy lifting and controlled lowering of loads.
- All models supplied with hooks for recommended optional LB-1 or LB-2 load binders.



RNR-2



**Rais-N-Rol™
2,000 lb
Capacity
Per Pair**

- 23" wide x 12.5" deep x 48.375" high (lowered height).
- I.D. fork span range 7.25" to 17.5".

OVERALL DIMENSIONS

w: 23"
h: 48.375"
d: 15.5"



RNR-4



**Rais-N-Rol™
4,000 lb
Capacity
Per Pair**

- 23" wide x 16.5" deep x 43.625" high (lowered height).
- I.D. fork span range 5" to 19.5".

OVERALL DIMENSIONS

w: 23"
h: 43.625"
d: 19.75"



RNR-6P



**Rais-N-Rol™ 6,000 lb
Capacity Per Pair**

- 23" wide x 16.5" deep.
- RNR-6(P): 41.375" H; RNR-64(P): 43.625" H.
- I.D. fork span range 6" to 19.5".

OVERALL DIMENSIONS

w: 23"
h: 41.375"
d: 18.75"



RNR-8



**Rais-N-Rol™
8,000 lb
Capacity
Per Pair**

- 23" wide x 16.5" deep x 43.375" high (lowered height).
- I.D. fork span range 6" to 19.5".

OVERALL DIMENSIONS

w: 23"
h: 41.375"
d: 20.75"



RNR-10



**Rais-N-Rol™
10,000 lb
Capacity
Per Pair**

- 23" wide x 16.5" deep x 47.625" high (lowered height).
- I.D. fork span range 6" to 19.5".

OVERALL DIMENSIONS

w: 24"
h: 47.625"
d: 21.75"

Part #	260086	260091	260087	260092	260088	260093	260138	260139	260089	260094	260090	260095
Model #	RNR-2	RNR-2P	RNR-4	RNR-4P	RNR-6	RNR-6P	RNR-64	RNR-64P	RNR-8	RNR-8P	RNR-10	RNR-10P
Capacity	2,000 lbs	2,000 lbs	4,000 lbs	4,000 lbs	6,000 lbs	6,000 lbs	6,000 lbs	6,000 lbs	8,000 lbs	8,000 lbs	10,000 lbs	10,000 lbs
Lift	5"	5"	12"	12"	12"	12"	12"	12"	6"	6"	6"	6"
Casters	5" x 2" Phenolic	5" x 2" Polyurethane	6" x 2" Steel	6" x 2" Polyurethane	6" x 2.5" Steel	6" x 2.5" Polyurethane	6" x 2.5" Steel	6" x 2.5" Polyurethane	8" x 2.5" Steel	8" x 2.5" Polyurethane	8" x 2.5" Steel	8" x 3" Polyurethane
Weight	170 lbs/PR	176 lbs/PR	315 lbs/PR	313 lbs/PR	325 lbs/PR	306 lbs/PR	359 lbs/PR	359 lbs/PR	390 lbs/PR	402 lbs/PR	480 lbs/PR	475 lbs/PR

Option: Load Binder Accessory

- Two 12' long nylon belts with heavy duty ratchet tighteners.
- Highly recommended for stabilizing large loads.

Part	Model #	Description
260096	LB-1	Delta rings secure belt to Rais-N-Rol
260147	LB-2	"E" track hooks secure belt to Rais-N-Rol

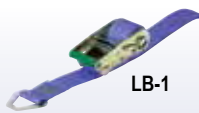

LB-1

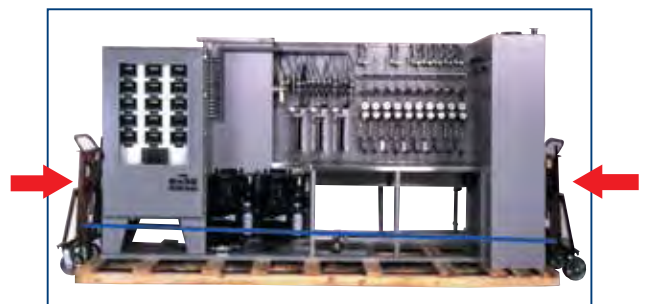

Panel becomes its own dolly.

LIFT EQUIPMENT

Furniture Mover

- Sold in pairs only.
- Two models: Manual Lift / Hydraulic Lift
- Economically priced.
- Great for moving furniture or odd shaped loads.
- Straps to secure load standard.
- Hydraulic unit with ratcheting strap tightener.
- 6" swivel casters.



Hydraulic
272952



Manual
272951

OVERALL DIMENSIONS

w:	23"	26.5"
h:	32"	42"
d:	15"	16"

Part #	272951	272952
Model #	MFM	HFM
Capacity	1,320 lbs per pair	3,950 lbs per pair
Lift Plate L x D	8.5" x 4.5"	23" X 2.25"
Lift Height	12"	10"
Casters	6" Moldon Polyurethane	6" Moldon Polyurethane
Weight	72 lbs	195 lbs



480020

Steel Deck Machine Dolly

- .25" thick steel plate.
- 2" x .5" aircraft quality, heat treated steel wheels.

OVERALL DIMENSIONS

w:	8.5"
h:	2.5"
d:	11.75"

Part #	480020	480001	480002	480003	480004	480019
Model #	HMS-2	HMS-8	HMS-15	HMS-30		HMS-2K
Capacity	10,000 lbs	2,000 lbs	8,000 lbs	15,000 lbs	30,000 lbs	4 HMS - 2's @ 2,000 lbs ea.
Wheel Size	2" x .5"	N/A	N/A	N/A	N/A	N/A
Roller Width	NA	1.875"	3.25"	3.25"	4"	1.875"
Roller Diameter	NA	.6875"	.9375"	1.1875"	1.1875"	.6875"
Weight	11.5 lbs	10 lbs	31 lbs	39 lbs	52 lbs	55 lbs

HeviMovers™ are made with precision ground and hardened steel rollers that form an endless chain which revolves around a central load-bearing plate in the frame. Weight of the load is transferred directly from load-bearing plate to rollers. This eliminates axle friction and requires less power to start and move the load. HeviMovers™ roll easily over cracks and pitted floor areas to reduce possible damage to goods.

HeviMover™ Machine Rollers

- Swivel-top for maximum maneuverability, full 360° rotation.
- Spring-loaded locking mechanism at 45° intervals.
- Only periodic cleaning and light re-oiling of roller chain needed.

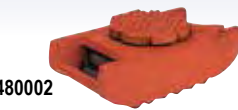

480002



HeviMover™ Kit #480019

- Includes 4 HMS-2 HeviMovers and 2 29" knocked down steering handles in a rugged steel tool box.

OVERALL DIMENSIONS

w:	16"
h:	7"
d:	7"

HeviMover™ Options

- Steering handles.
- Turning bar.

Part #	480005	480006
Model #	HMH-36-1	HMH-48-1
Description	36" steering handle for HMS-2	48" steering handle for HMS-2
Weight	6 lbs	7 lbs

Part #	480007	480008
Model #	HMH-36-2	HMH-48-2
Description	36" steering handle for HMS-8, 15, 30	48" steering handle for HMS-8, 15, 30
Weight	6 lbs	7 lbs

Part #	480009
Model #	HMH-TB-2
Description	36" turning bar for HMS-8, 15, 30
Weight	14.5 lbs

Aluminum Platform Truck Features:

- Aluminum is corrosion resistant and maintains clean appearance.
- Strong enough to handle up to 3,000 lbs (depending upon caster selection).
- Lightweight aluminum allows for easy maneuverability.
- Handle included.
- Corner sockets at both ends allow handles to be used on either or both ends of truck.
- For truck platform height, add 2.5" to caster height (see caster option chart).
- Bolt on casters. (Casters Sold Separately)—choose from caster option chart.



DO NOT EXCEED
3,000 LB
STRUCTURAL
CAPACITY



ATP-3048-MR6



DO NOT EXCEED
3,000 LB
STRUCTURAL
CAPACITY



ASD-3048-PN8

ATP Series - Aluminum Treadplate Mode

- Structural capacity of any size platform **NOT** to exceed 3,000 lbs.
- Slip-resistant diamond pattern surface.
- Solid one piece platform surface construction.

OVERALL DIMENSIONS

w:	24"	24"	30"	30"	36"	36"
h:	2.5"	2.5"	2.5"	2.5"	2.5"	2.5"
d:	36"	48"	48"	60"	60"	72"

ASD Series - Aluminum Smooth Deck

- Structural capacity of any size platform **NOT** to exceed 3,000 lbs.
- Smooth surface that is easy to keep clean.
- Solid one piece platform surface construction.

OVERALL DIMENSIONS

w:	24"	24"	30"	30"	36"	36"
h:	2.5"	2.5"	2.5"	2.5"	2.5"	2.5"
d:	36"	48"	48"	60"	60"	72"

Part #	350036	350037	350039	350040	350042	350043	350027	350028	350030	350031	350033	350034
Model #	ATP-2436	ATP-2448	ATP-3048	ATP-3060	ATP-3660	ATP-3672	ASD-2436	ASD-2448	ASD-3048	ASD-3060	ASD-3660	ASD-3672
Structural Capacity	NOT TO EXCEED 3,000 LBS						NOT TO EXCEED 3,000 LBS					
Platform	24" x 36"	24" x 48"	30" x 48"	30" x 60"	36" x 60"	36" x 72"	24" x 36"	24" x 48"	30" x 48"	30" x 60"	36" x 60"	36" x 72"
Weight	32 lbs	40 lbs	45 lbs	54 lbs	61 lbs	71 lbs	27 lbs	33 lbs	37 lbs	44 lbs	49 lbs	59 lbs

Actual capacity of assembled platform is dependent upon caster capacity but should never exceed the platform's structural capacity, regardless of caster type.

Caster Options for ATP and ASD Series Platform Trucks

(Two rigid, two swivel per set)

Part #	250046	250047	250049	250050	250051	250052	250053	250055	250056	250250
Model #	SR-5A	SR-5	SR-6	MR-6	MP-6	PR-6	MR-8	MP-8	PR-8	PN-8
Capacity	750 lbs	2,000 lbs	2,000 lbs	2,000 lbs	3,000 lbs	3,000 lbs	2,400 lbs	3,000 lbs	3,000 lbs	1,200 lbs
Wheel Size	5" x 1.5"	5" x 2"	6" x 2"	6" x 2"	6" x 2"	6" x 2"	8" x 2"	8" x 2"	8" x 2"	8" x 2.5"
Wheel Type	Polyolefin	Polyolefin	Polyolefin	Moldon Rubber	Moldon Polyurethane	Phenolic	Moldon Rubber	Moldon Polyurethane	Phenolic	Pneumatic
"H" Dimension Floor to Platform Top	9"	9.25"	10"	10"	10"	10"	12"	12"	12"	12.5"
Caster Height	6.50"	6.75"	7.5"	7.5"	7.5"	7.5"	9.5"	9.5"	9.5"	10"
Weight	14 lbs per set	20 lbs per set	26 lbs per set	26 lbs per set	24 lbs per set	26 lbs per set	28 lbs per set	27 lbs per set	30 lbs per set	29 lbs per set

Actual capacity of assembled platform is dependent upon caster capacity but should never exceed the platform's structural capacity, regardless of caster type.

Corner Bumper Option

- Part #250022 Model #CB
- Includes 4 bumpers.
- To order, add -CB to the end of Truck Model #.

Example: ASD-2436-CB

Perimeter Bumper Option

- Part #250023 Model #PB
- To order, add -PB to the end of Truck Model #.

Example: ASD-2436-PB

Extra Push Handle Option

- Truck Width - 24" Part #052574
- 30" #052575
- 36" #052576
- To order, add -PH2 to the end of Truck Model #.

Example: ASD-2436-PH2



**DO NOT EXCEED
2,400 LB
STRUCTURAL
CAPACITY**

273601



**DO NOT EXCEED
1,200 LB
STRUCTURAL
CAPACITY**

273607

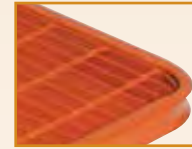

Close-up of grid deck



273297

Steel Grid Deck Platform Truck

Thrifty Plate Aluminum Tread Platform Trucks - Commercial Quality (Import)

- Structural capacity of any size platform **not** to exceed 2,400 lbs.
- Platforms and casters sold separately.
- Casters determine capacity - 2,400 lbs or less.
- Non-marking gray corner bumpers.
- Platform top to top of handle - 32".
- **Replacement Corner Bumper Option - Part # 273611 (includes 4 bumpers + hardware).**
- **24" Extra Push Handle - Part # 273609.**
- **30" Extra Push Handle - Part # 273610.**

Thrifty Plate Aluminum Tread Platform Trucks - Light Duty (Import)

- Structural capacity of any size platform **not** to exceed 1,200 lbs.
- Platforms and casters sold separately.
- Casters determine capacity - 1,200 lbs or less.
- Non-marking gray corner bumpers.
- Platform top to top of handle - 27.625".
- **Replacement Corner Bumper Option - Part # 273616 (includes 4 bumpers + hardware).**
- **24" Extra Push Handle - Part # 273614.**
- **30" Extra Push Handle - Part # 273615.**

- Sturdy open grate design provides high strength and prevents accumulation of water and small debris.
- Durable powder coat paint finish.
- (2) 8" x 2" rigid casters and (4) 6" x 1.5" swivel end casters.
- Tilt design allows truck to pivot on its own radius.
- Platform height 10.75", height to top of handle 35.5".

OVERALL DIMENSIONS			
w: 25"	25"	31"	31"
h: 2.625"	2.625"	2.625"	2.625"
d: 37"	49"	49"	61"

OVERALL DIMENSIONS			
w: 25"	25"	31"	31"
h: 1.625"	1.625"	1.625"	1.625"
d: 37"	49"	49"	61"

OVERALL DIMENSIONS	
w: 30"	30"
h: 35.5"	35.5"
d: 63"	63"

Part #	273601	273602	273603	273604	273605	273606	273607	273608	273297
Model #	CQ2436	CQ2448	CQ3048	CQ3060	LD2436	LD2448	LD3048	LD3060	
Structural Capacity	NOT TO EXCEED 2,400 LBS				NOT TO EXCEED 1200 LBS				1,750 lbs
Platform	24" x 36"	24" x 48"	30" x 48"	30" x 60"	24" x 36"	24" x 48"	30" x 48"	30" x 60"	30" x 50"
Weight	28 lbs	36 lbs	43 lbs	53 lbs	19 lbs	23 lbs	28 lbs	34 lbs	170 lbs

Actual capacity of assembled platform is dependent upon caster capacity but should never exceed the platform's structural capacity, regardless of caster type.

Caster Options for Thrifty Plate Platform Trucks

- Each Caster Set includes 2 rigid, 2 swivel casters.

Part #	273612	273613	172244	172245
Capacity	2,000 lbs	2,400 lbs	1,200 lbs	1,500 lbs
Wheel Size	6" x 2"	8" x 2"	8" x 2.5"	10" x 3.5"
Wheel Type	Moldon Rubber Aluminum Hub	Moldon Rubber Aluminum Hub	Full Pneumatic Zinc Steel Hub	Full Pneumatic Zinc Steel Hub
H-CQ Dimension - Floor to Platform Top	10.375"	12.125"	12.625"	14.625"
H-LD Dimension - Floor to Platform Top	9.375"	11.125"	11.625"	13.625"
Caster Height	7.75"	9.5"	10"	12"
Weight	26 lbs per set	28 lbs per set	26 lbs per set	34 lbs per set

Actual capacity of assembled platform is dependent upon caster capacity but should never exceed the platform's structural capacity, regardless of caster type.

Steel Platform Truck Features:

- Heavy duty 12 gauge steel reinforced welded construction.
- Constructed for both standard corner or diamond caster mounting pattern.
- Removable two cross-brace handle can be inserted in either end.
- Choose your caster. Platforms and casters sold separately, except #272265.
- All platforms include one handle. Additional handles available as an option. (except #272265)
- All listed capacities are based on evenly distributed loads.

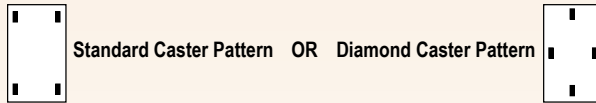

Steel Platform Trucks (Casters sold separately)

- 32" high handles from platform top.

	OVERALL DIMENSIONS						
w:	24"	24"	27"	30"	30"	36"	36"
h:	2"	2"	2"	2"	2"	2"	2"
d:	39.5"	48"	57.5"	51.5"	63.5"	63.5"	75.5"

Economy Steel Platform Truck

- Ships complete. Platform, one handle, four 5" x 1.25" casters.
- Deck height - 5.75", handle height - 41".
- Maximum capacity 750 lbs.

OVERALL DIMENSIONS

w:	24"
h:	41"
d:	42"

Part #	272266	272267	272268	272269	272270	272271	272272	272265
Structural Capacity	NOT TO EXCEED 4,000 LBS							750 lbs
Platform W x L	24" x 36"	24" x 48"	27" x 54"	30" x 48"	30" x 60"	36" x 60"	36" x 72"	24" x 42"
Caster	chart selection	chart selection	chart selection	chart selection	chart selection	chart selection	chart selection	5" x 1.25" rubber
Weight	86 lbs	65 lbs	82 lbs	115 lbs	135 lbs	126 lbs	172 lbs	62 lbs

Actual capacity of assembled platform is dependent upon caster capacity but should never exceed the platform's structural capacity, regardless of caster type.

Caster Sets

- Each caster set contains 2 swivel and 2 rigid casters.

Extra Handles for Trucks with

24" Wide Platform 27" Wide Platform 30" Wide Platform 36" Wide Platform

Part #	272191	272192	272193	272194	272195	272201	272202	272203	272197	272198	272199	272200
Set Capacity	1,600 lbs	2,500 lbs	4,000 lbs	1,600 lbs	1,600 lbs	1,600 lbs	1,800 lbs	2,200 lbs	N/A	N/A	N/A	N/A
Description	6" x 1.375" Polyolefin	8" x 2" Polyolefin	8" x 2" Moldon Polyurethane on cast iron hub	8" x 2.5" Full Pneumatic	10" x 3.5" Full Pneumatic	5" x 2" Moldon Rubber on cast iron hub	6" x 2" Moldon Rubber on cast iron hub	8" x 2" Moldon Rubber on cast iron hub	N/A	N/A	N/A	N/A
"H" Dimension Floor to Platform Top	9"	11.5"	11.5"	12.25"	14.00"	8.5"	9.5"	12.5"	N/A	N/A	N/A	N/A
Caster Height	7"	9.5"	9.5"	10.25"	12"	6.5"	7.5"	10.25"	N/A	N/A	N/A	N/A
Weight	9 lbs	31 lbs	42 lbs	31 lbs	40 lbs	32 lbs	29 lbs	39 lbs	15 lbs	16 lbs	17 lbs	19 lbs

Actual capacity of assembled platform is dependent upon caster capacity but should never exceed the platform's structural capacity, regardless of caster type.

Power Drive Platform Truck

- 47¼" turning radius.
- Deck height from floor: 12.375".
- Finger tip variable speed controller with forward and reverse modes. Illuminated battery status indicator.
- Key lock and emergency stop.
- Motor: 370 watts.
- Maximum climbing incline: 8°.
- (2) 12v 40 A.H. batteries and charger included.
- Charge time: 7-8hr. / Continuous run time: 6 hr.
- Motor controller: Curtis 110 amp.
- Front wheels: 10" pneumatic.
- Rear swivel polyurethane casters: 5" x 2".
- Reverse direction safety beeper and reduced speed in reverse for added safety.
- Full perimeter bumper helps prevent wall damage.
- Rear panel grid helps keep cargo in place.
- Durable white powder coat finish with black rubber deck mat.
- 43" handle height.
- Steel thickness 2.5 mm.



272416



272413

OVERALL DIMENSIONS

w: 24"	24"	30"	30"
h: 43"	43"	43"	43"
d: 38.5"	50.5"	50.5"	62.5"

Part #	272413	272414	272415	272416
Capacity	1,100 lbs	1,100 lbs	1,100 lbs	1,100 lbs
Shelf Size	24" x 36"	24" x 48"	30" x 48"	30" x 60"
Wheel Type	10" Pneumatic	10" Pneumatic	10" Pneumatic	10" Pneumatic
Casters	5" x 2"	5" x 2"	5" x 2"	5" x 2"
Weight	243 lbs	254 lbs	276 lbs	300 lbs



Optional Tow Handle and Eye Hook
Part #272073



Solid Platform
272055



Flush Open Deck
272058



Open Deck
Carpet Ends
272060



Open Deck
Rubber Ends
272062

Wood Dollies

- 4 swivel casters/3" hard rubber or 4" hard plastic.
- Seasoned hardwood with flush top bolted construction.
- Optional tow handle and eye hook.
- Ships KD and boxed via ground service.

Description	Size	Part # 3" Casters	Part # 4" Casters
		(Weight / Capacity)	(Weight / Capacity)
Solid Platform	24" x 16"	272053 (18 lbs / 900 lbs)	272063 (20.5 lbs / 1,200 lbs)
	27" x 18"	272054 (20.5 lbs / 900 lbs)	272064 (23 lbs / 1,200 lbs)
	30" x 18"	272055 (23.5 lbs / 900 lbs)	272065 (26 lbs / 1,200 lbs)
	36" x 24"	272056 (32 lbs / 900 lbs)	272066 (34.5 lbs / 1,200 lbs)
Flush Open Deck	24" x 16"	272057 (14.5 lbs / 900 lbs)	272067 (17 lbs / 1,200 lbs)
	30" x 18"	272058 (16.5 lbs / 900 lbs)	272068 (19 lbs / 1,200 lbs)
	36" x 24"	272059 (21.5 lbs / 900 lbs)	272069 (24 lbs / 1,200 lbs)
Open Deck Carpet Ends	30" x 18"	272060 (16.5 lbs / 900 lbs)	272070 (19 lbs / 1,200 lbs)
	36" x 24"	272061 (18.5 lbs / 900 lbs)	272071 (21 lbs / 1,200 lbs)
Open Deck Rubber Ends	30" x 18"	272062 (18 lbs / 900 lbs)	272072 (20.5 lbs / 1,200 lbs)



270456



270461

Wire Caged Steel Platform Trucks

- Great for moving loose materials or small boxes.
- Two models, regular or heavy duty.
- Moldon non-marking TPR rubber wheels.
- Removable cages.
- Ships KD and boxed.
- Casters: two swivel, two rigid.

OVERALL DIMENSIONS

w:	23"	30"
h:	36"	40"
d:	35"	48"



270388

Commercial Quality Steel Panel Cart

- 8" Moldon non-marking TPR rubber wheels.
- Wraparound corner bumpers.
- Great for commercial applications.
- Casters: two swivel, two rigid.
- Removable side rails.

OVERALL DIMENSIONS

w:	30"
h:	37"
d:	48"



272226

Standard Greenline Steel Panel Carts

- Removable plastic basket for carrying tools.
- Detachable center bar for moving bulky items like tables and partitions.
- Great for sheet products like dry wall and plywood.
- 4" x 2" Phenolic casters 2 swivel/2 rigid withbrakes.
- Ships KD.

OVERALL DIMENSIONS

w:	27"
h:	43"
d:	32"



272227

Heavy Duty Greenline Steel Panel Carts

- Heavy duty steel platform and supports.
- 5" x 2" Moldon polyurethane casters, 2 swivel/2 rigid with brakes.
- 12 1/8" spacing between removable vertical supports.
- Ships KD.

OVERALL DIMENSIONS

w:	29"
h:	34"
d:	36"



273298

Steel Panel Cart

- Steel, powder coat paint finish.
- Deck dimensions: 48" x 30.25".
- 2 rigid, 2 swivel rubber casters - 4" x 2".

OVERALL DIMENSIONS

w:	30.25"
h:	45.5"
d:	51.5"

Part #	270456	270461	270388	272226	272227	273298
Capacity	660 lbs	1,100 lbs	1,100 lbs	1,540 lbs	4,400 lbs	1,750 lbs
Platform/Deck Size	23" x 35"	30" x 48"	30" x 48"	27" x 32"	29" x 36"	30.25" x 48"
Handle Height	36"	40"	37"	43"	34"	45.5"
Deck Height	8.5"	11.5"	11.5"	10.5"	10.5"	10"
Caster Size	5" x 2"	5" x 2"	8" x 2"	4" x 2"	5" x 2"	4" x 2"
Weight	66 lbs	124 lbs	118 lbs	138 lbs	199 lbs	150 lbs



270339



273565

*Steel Shelf Option for 273291



273292



273293



273296

Folding Handles



273291



273295



273294

U-boats

- 8 models and a variety of sizes to suit your application.
- Painted steel, galvanized steel, aluminum, wood deck models available.
- Tilting and non-tilting models.
- Removable handles, except on folding handle model.
- 2 rigid center casters and 4 swivel end casters allow trucks to turn on their own radius. Provides easy maneuverability in narrow aisles and confined areas.
- **#273565 galvanized steel shelf option for #273291 U-boat only (16"W x 60"L). 350 lb. maximum capacity with evenly distributed load.**

* #273291 U-boat can handle two shelves.

OVERALL DIMENSIONS

w:	16"	16"	16"	18"	24"	17.5"	16.25"
h:	61"	61"	60"	60"	60"	61.25"	60"
d:	64"	63"	63"	63"	63"	53"	63"

Part Number	273296	270339	273291	273292	273295	273293	273294
Capacity	1,750 lbs	1,322 lbs	1,750 lbs	1,750 lbs	1,750 lbs	1,750 lbs	1,750 lbs
Platform (W x L)	16" x 59.5"	16" x 63"	16" x 60"	18" x 60"	24" x 60"	16" x 48"	16" x 60"
Material	Aluminum	Aluminum	Galvanized steel	Galvanized steel	Galvanized Steel	Painted Steel	Painted Steel
Deck Type	Open	Open	Tread plate	Tread plate	Tread plate	Smooth	Wood
Tilting	Yes	Yes	No	No	Yes	Yes	Yes
2 Rigid Wheels (center)	6" x 2" Polyurethane	6" x 2" Polyurethane	8" x 2" Polyurethane	8" x 2" Polyurethane	8" x 2" Polyurethane	6" x 2" Moldon Rubber	8" x 2" Moldon Rubber
4 Swivel Casters (ends)	5" x 1.25" Polyurethane	5" x 1.25" Polyurethane	4" x 1.25" Polyurethane	4" x 1.25" Polyurethane	4" x 1.25" Polyurethane	4" x 1.25" Moldon Rubber	4" x 1.25" Moldon Rubber
Deck (h) (at center)	9.5"	9.5"	10.75"	10.75"	10.75"	7.5"	11.5"
Height - Handle top	62"	61"	60"	60"	53.25"	61.25"	60"
Weight (lbs.)	63.5 lbs	91 lbs	97 lbs	109 lbs	116.5 lbs	82 lbs	115.5 lbs

TWO MODELS:
Deluxe - Best quality truck on the market.
Economy - For the price-conscious buyer



272019



272235



Look
Pneumatic tires

ALL
STAINLESS
STEEL:
Handle, Platform
and Caster Rigs



270458



Stainless
Steel Folding
Handle Truck

- Fold down handle for easy storage.
- Caster: sealed bearing with stainless rig.
- TPR rubber non-marking caster wheels.
- Vinyl perimeter bumper.
- Boxed and UPS shippable.

Steel Folding Handle Trucks

- Fold down handle for easy storage.
- Enameled finish with non-skid heavy vinyl deck surface.
- Protective vinyl perimeter bumpers.
- 4" & 5" caster wheels TPR non-marking rubber.
- Boxed and UPS shippable.

OVERALL DIMENSIONS - DELUXE SERIES

w: 19"	23"	23"
h: 32.5"	37.5"	43.5"
d: 29"	35"	35"

OVERALL DIMENSIONS - ECONOMY SERIES

w: 19"	23"	23"
h: 32.5"	32.5"	38.5"
d: 29"	35"	35"

OVERALL DIMENSIONS

w: 19"	22.5"
h: 34.5"	34"
d: 29"	34"

Part #	272019	272035	272235	272238	272239	278762	270457	270458
Model #	Deluxe	Deluxe	Deluxe	Economy	Economy	Economy	Deluxe	Deluxe
Capacity	440 lbs	660 lbs	660 lbs	275 lbs	400 lbs	400 lbs	440 lbs	770 lbs
Platform Size	19" x 29"	23" x 35"	23" x 35"	19" x 29"	23" x 35"	23" x 35"	19" x 29"	22.5" x 34"
Caster Size	4"	5"	8" Pneumatic	4"	5"	8" Pneumatic	2 swivel/2 rigid	2 swivel/2 rigid
	2 swivel/2 rigid	2 swivel/2 rigid	2 swivel/2 rigid	2 swivel/2 rigid	2 swivel/2 rigid	2 swivel/2 rigid	4" Stainless Rigs	4" Stainless Rigs
Handle Height	32.5"	37.5"	43.5"	32.5"	32.5"	38.5"	34.5"	34"
Weight	28 lbs	47 lbs	69.7 lbs	21 lbs	41 lbs	69 lbs	26 lbs	37 lb



270382



Aluminum Folding Ergo-Handle Truck

- Ergonomic European style handle.
- Corner bumpers.
- Boxed and UPS shippable.

OVERALL DIMENSIONS

w: 24"
h: 41"
d: 35.5"



272076



Aluminum Folding Handle Truck

- TPR rubber non-marking caster wheels.
- Lightweight aluminum deck.
- Wrap around corner bumper.
- Boxed and UPS shippable.

OVERALL DIMENSIONS

w: 18.5" 24"
h: 34.5" 35.5"
d: 29" 35.5"



270389



Aluminum Folding Handle Long Deck Truck

- TPR rubber non-marking caster wheels.
- Lightweight aluminum deck.
- Wrap around corner bumper.
- Six 5" casters, four swivel on ends, two rigid in center.
- Boxed and UPS shippable.

OVERALL DIMENSIONS

w: 18.5"
h: 35.5"
d: 58.5"



272048

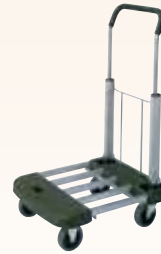

Aluminum Professional Series Telefolding Truck

- Deck extends from 21" to 29.5".
- Push button, quick conversion.
- Anti-impact, non-skid polypropylene and aluminum deck.
- Non-marking 4" moldon rubber wheels.
- Sponge rubber coated handle.
- Boxed and UPS shippable.

OVERALL DIMENSIONS

w: 17.5"
h: 36.5"
d: 21" - 29.5"



272250



Aluminum Economy Telefolding Truck

- Deck extends from 20" to 28".
- Full size platform truck that folds to briefcase size.
- Strong, lightweight aluminum frame.
- Protective vinyl corner bumpers.
- Boxed and UPS shippable.
- Rubber wheel with plastic hub.
- Swivel casters with brake.

OVERALL DIMENSIONS

w: 16"
h: 36.5"
d: 20" - 28"

Part #	270382	272076	272112	270389	272048	272250
Capacity	660 lbs	350 lbs	550 lbs	660 lbs	330 lbs	300 lbs
Platform W x L	24" x 35.5"	18.5" x 29"	24" x 35.5"	18.5" x 58.5"	17.5" x 21" - 29.5"	16" x 20" - 28"
Handle Height	41"	34.5"	35.5"	35.5"	36.5"	37.75"
Caster Size	7" 2 swivel/2 rigid	4" 2 swivel/2 rigid	5" 2 swivel/2 rigid	5" 4 swivel/2 rigid	4" 2 swivel/2 rigid	4" 2 swivel w/brake/2 rigid
Weight	46 lbs	26 lbs	33 lbs	44 lbs	19 lbs	21 lbs



260290



260291



260292



260293



260294

Stainless Steel Carts

- 430 Stainless Steel shelf and frame construction.
- NSF Approved.
- 4 swivel, zinc plated casters with non-marking rubber tread polyurethane hub wheels.
- 3 shelves
 - .040" thick
 - top and center 1" lip, 3 sides
 - bottom flat, no lip.
- Sound deadening aluminum pad on underside of top shelf.
- Welded construction.
- Protection bumpers on legs and handle.
- Shelves have reinforced hemmed front.
- Overall capacity based upon evenly distributed loads.*

OVERALL DIMENSIONS

w:	27.5"	30.75"	27.625"	31"	39.25"
h:	32.125"	33"	32"	32"	37.25"
d:	16.25"	18.375"	16.75"	19"	22.375"

Part #	260290	260291	260292	260293	260294
Model #	SS3C11	SS3C22	SS4C11	SS4C22	SS4C44
Overall Capacity	300 lbs	300 lbs	500 lbs	500 lbs	500 lbs
* Capacity Per Shelf	100 lbs	100 lbs	166 lbs	166 lbs	166 lbs
Shelf Size (L x W)	24" x 15.5"	27.125" x 17.625"	24" x 15.75"	27.375" x 18"	35.125" x 21"
Shelf Lip Height	1"	1"	1"	1"	1"
Distance Between Shelves	12.75"	13.25"	12.5" top/14.625" bottom	13" top/14.5" bottom	14.375" top/14.5" bottom
Caster Wheel	3.5" dia. x .75" w	3.5" dia. x .75" w	4" dia. x .75" w	4" dia. x .75" w	5" dia. x 1.25" w
Weight	30.5 lbs	40 lbs	36 lbs	42 lbs	67 lbs



270166



270169

Steel Service Carts

- 500 lb. capacity, evenly distributed load.
- 5" x 1.25" hard rubber casters - 2 swivel, 2 rigid.
- 20 gauge steel trays and 14 gauge corner posts.
- 3.5" tray depth.
- Baked enamel paint finish.
- 2 sizes, 16" x 30" and 24" x 36".
- Top tray can be inverted for flat work surface.
- Drawer with roller glides for easy operation.
- Shipped KD and boxed.

OVERALL DIMENSIONS

w:	16"	16"	24"	24"
h:	32"	3.5"	32"	3.5"
d:	33"	30"	39"	39"



270434 cart with
270454 3rd tray



270434

Deluxe Plastic Service Cart

- 550 lb. capacity, evenly distributed load.
- Available in two sizes: 16" x 30" and 24" x 36".
- Optional 3rd shelf.
- Heavy duty construction resists chips, dents, and rust.
- Push handle has compartments to accommodate a variety of tools, labels, small parts, etc.
- Shipped KD, boxed, and includes 5" non-marking casters - 2 swivel, 2 rigid.
- Caster wheels; 5" TPR (thermoplastic rubber tread) molded onto polypropylene hub.
- Shelf depth 2.625".

OVERALL DIMENSIONS

w:	16.5"	16.5"	25"	25"
h:	33.5"	4.125"	35.5"	4.125"
d:	37.5"	31"	43.5"	37.25"

Part #	270166	270167	270168	270169	270433	270453	270434	270454
Model #	SC-1630	SCT-1630	SC-2436	SCT2-436	DPC-1630	DES-1630	DPC-2436	DES-2436
Capacity	500 lbs	N/A	500 lbs	N/A	550 lbs	N/A	550 lbs	N/A
No. of Trays	2	Optional	2	Optional	2	Optional	2	Optional
Description	Cart	3rd tray	Cart	3rd tray	Service cart	3rd tray	Service cart	3rd tray
Dimensions	16" x 30"	16" x 30"	24" x 36"	24" x 36"	16" x 30"	16" x 30"	24" x 36"	24" x 36"
Weight	35 lbs	11 lbs	48 lbs	17 lbs	37 lbs	9 lbs	50 lbs	13 lbs



270482



270483



270493
Flat Work Surface

Standard Plastic Service Cart

- 500 lb. maximum capacity, evenly distributed load.
- Available in two sizes: 16" x 30" and 24" x 36".
- Optional 3rd shelf.
- Shipped KD, boxed, and includes 5" non-marking casters - 2 swivel, 2 rigid.
- Caster wheels; 5" TPR (thermoplastic rubber tread) molded onto polypropylene hub.
- Very economical.
- Shelf depth 2.625".

OVERALL DIMENSIONS

w:	17.375"	17.375"	25.5"	25.5"	25.5"
h:	32.5"	4.125"	32.5"	4.125"	32.5"
d:	34.25"	34.25"	40.25"	40.25"	40.25"

Part #	270482	270484	270483	270485	270493
Model #	SD-1630	SDES-1630	SD-2436	SDES-2436	SDF-2436
Capacity	500 lbs	N/A	500 lbs	N/A	500 lbs
No. of trays	2	Optional	2	Optional	2
Description	Cart	3rd tray	Cart	3rd tray	Flat top cart
Dimensions	16" x 30"	16" x 30"	24" x 36"	24" x 36"	25.5" x 34"
Weight	36 lbs	9 lbs	49 lbs	13 lbs	43 lbs

Economy Plastic Service Cart

- 330 lb. maximum capacity, evenly distributed load.
- Optional 3rd shelf.
- Shipped KD, boxed, and includes 5" non-marking casters - 2 swivel, 2 rigid.
- Value priced.
- Caster wheels; 5" TPR (thermoplastic rubber tread) molded onto polypropylene hub.
- Shelf depth 2".



270494

OVERALL DIMENSIONS

w:	17.25"	17.25"
h:	30.635"	3.125"
d:	34"	34"

Part #	270494	270496
Model #	EPC-1630	EES-1630
Capacity	330 lbs	N/A
No. of Trays	2	Optional
Description	Cart	3rd tray
Dimensions	16" x 30"	16" x 30"
Weight	36 lbs	9 lbs

Value Plastic Platform Trucks

- Economically priced.
- Fixed and folding handle designs.
- Plastic platform with steel handle.
- Steel reinforced platform.
- Platform height - 8".



272281



OVERALL DIMENSIONS

w:	19.25"	22"
h:	34.5"	34.5"
d:	27.5"	33.5"

Part #	272281	272282	272946
Capacity	265 lbs	265 lbs	400 lbs
Folded (H x W x D)	N/A	N/A	2.5" x 20" x 34"
Wheel Size	5" x 1" rubber caster	5" x 1" rubber caster	5" swivel caster
Platform W x D	119.25" x 22.25"	22" x 30.5"	20" x 31"
Handle Type	34.5" fixed	34.5" fixed	37.5" folding
Construction	Plastic	Plastic	Polyurethane
Weight	20 lbs	26.5 lbs	24 lbs

Bi-Mode Poly Folding Handle Truck

- Push/Pull mode - handle is tilted allowing truck to be pulled or pushed.
- Dolly mode - handle folds flush with surface of deck allowing truck to be used as a dolly without cargo coming in contact with handle. Cargo stays flat and secure on deck.
- Casters—two swivel, two rigid 5" non-marking rubber wheels.

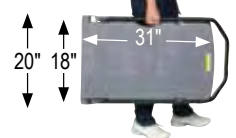

272946



OVERALL DIMENSIONS

w:	20"
h:	37.5"
d:	34"



272231
Deluxe Large
Office Cart

272228
Standard Compact
Office Cart



272230
Deluxe Compact
Office Cart

Wire Office Carts

- Ideal for carrying hanging files (letter and legal) mail, packages and tools.
- Swivel casters.
- Removable baskets.
- 1" diameter, 18 gauge tubular construction.
- All metal surfaces plated for long life.
- Shipped KD and boxed via UPS.

OVERALL DIMENSIONS

w:	20"	23.75"	23.75"
h:	37.5"	38.25"	38.5"
d:	33"	33.5"	43"



272233

Foldaway Table Top Cart

- Folds for easy storage.
- Ideal for transporting instruments and office equipment.
- Laminate surface with vinyl edge.
- Four 4" swivel ball bearing casters.
- Lower basket: 21" x 13".

OVERALL DIMENSIONS

w:	19"
h:	28.75"
d:	28"



272079



272156



ADAPTER
#272150

Office Caddy

- Multi-purpose service truck ideal for offices and service vehicles.
- Fits in most car trunks.
- Easily converts for use as a four wheel rolling table or two or four wheel hand truck. 7 possible positions.
- Oak color top with vinyl edge.
- 8" x 1.75" easy roll semi-pneumatic wheels and 2.5" hard rubber swivel casters.

OVERALL DIMENSIONS

w:	19"
h:	55"
d:	18"

Desk Mover & Pedestal Adapter

- Move a desk without emptying drawers or clearing the top.
- Easy operation, automatically locks in the raised position.
- Vinyl coated lift rack prevents damage and slipping.
- Adjustable pedestal adapter required to move desks with single pedestal - **Part # 272150**.
- Capacity 600 lbs.
- Boxed and UPS shippable.
- Swivel casters.

OVERALL DIMENSIONS

w:	31.75"	31.75"	31.75"
h:	39.5"	39.5"	39.5"
d:	23"	23"	23"

Part #	272228	272230	272231	272233	272079	272155	272156	272157
Capacity	200 lbs	200 lbs	250 lbs	200 lbs	as 2 wheel truck: 200 lbs as 4 wheel truck: 400 lbs as 4 wheel table: 100 lbs	600 lbs	600 lbs	600 lb
Basket/Table Size	25" x 17.25" x 11"	25 x 17.25" x 11"	36 x 17.25" X 11"	28" x 19"	19" x 23.5"	N/A	N/A	N/A
Lower Basket	25" x 17.25" x 7.5"	25 x 17.25" x 7.5"	36 x 17.25" X 7.5"	N/A	N/A	N/A	N/A	N/A
Handle Height	N/A	N/A	N/A	N/A	55"	39.5"	40"	41.25"
Deck Height	N/A	N/A	N/A	28.75"	32"	N/A	N/A	N/A
Collapsed Size	N/A	N/A	N/A	6"	11.5"	N/A	N/A	N/A
Raised Height	N/A	N/A	N/A	N/A	N/A	9.75"	10.25"	11.25"
Lowered Height	N/A	N/A	N/A	N/A	N/A	4.25"	4.75"	6"
Caster Size	4" hard rubber	5" hard rubber	5" hard rubber	4"	2.5"	2.5"	3"	4"
Wheel Size	4" hard rubber	10" semi-pneumatic	10" semi-pneumatic	N/A	8" x 1.75"	N/A	N/A	N/A
Weight	41 lbs	49 lbs	62 lbs	32 lbs	42 lbs	44 lbs	45 lbs	46 lbs



220646

WESCO® lightweight folding trucks

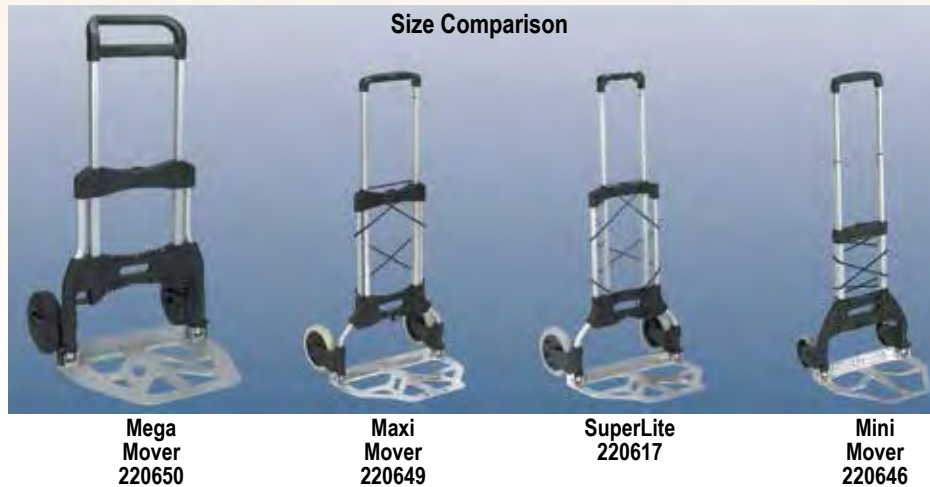

Mega Mover, Maxi Mover, Superlite & Mini Mover Folding Trucks

- Space saving folding design. Fits into small storage spaces or car trunks.
- Elastic straps for securing load.
- Aluminum or steel construction.
- **Non-marking wheels.**
- Mini Mover fits into overhead airline compartments.

OVERALL DIMENSIONS EXTENDED

w: 26.5"	19"	19"	15.5"
h: 47"	42"	42"	41"
d: 25.5"	19"	19"	17.5"

Part #	220650	220649	220617	220646
Capacity	550 lbs	275 lbs	175 lbs	110 lbs
Folded (H x W x D)	34" x 23.5" x 4.75"	29.5" x 19" x 2"	29.5" x 19" x 2"	24" x 15.25" x 2"
Wheel Size	8" x 2.5" pneumatic wheel	7" x 1.5" rubber tread / poly hub	7" x 1.5" rubber tread / poly hub	5" x 1.25" rubber tread / poly hub
Noseplate/Platform Dimensions (W x D)	23.5" x 18" Noseplate	19" x 12" Noseplate	19" x 12" Noseplate	15" x 12.5" Noseplate
Handle Type	34" - 47"	29.5" - 42"	29.5" - 42"	24" - 41"
Construction	Aluminum	Steel	Aluminum	Aluminum
Weight	33 lbs	14 lbs	11.5 lbs	9 lbs

WESCO® TILT CARTS

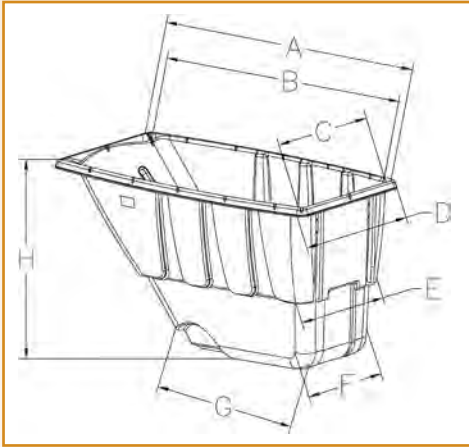

Fork Pocket



**272577
Standard/Recycle**



**272575
Utility**



**272583
Standard**

Tilt Carts

- Heavy-duty, molded, FDA compliant material, polyethylene bin.
- Easy to move and dump.
- Wheels: 10" x 2.75" / 12" x 3" black rubber tread tire, molded to polyolefin hub.
- Swivel casters, polyurethane wheels.
- 1/2 and 1 cubic yard bins.

- All models include bin, frame, handle, wheels and casters.
- Optional black polyethylene hinged lids:
#272586 - 1/2 cu. yd. and #272587 - 1 cu. yd. (304 stainless hinge).
- Four grades: utility, standard, heavy duty and forklift.
- **Blue recycle** 1/2 cubic yard bin available: #272577.

Part #	272575	272576	272577	272578	272579	272580	272581	272582	272583	272584	272585
Model #	1/2 U450B	1/2 S850B	1/2 S850BLRC	1/2 S850R	1/2 HD1400B	1/2 FL850B	1U850B	1S1250B	1S1250R	1HD2100B	1FL1250B
Type	Utility	Standard	Standard/Recycle	Standard	Heavy Duty	Fork Lift	Utility	Standard	Standard	Heavy Duty	Fork Lift
Cubic Yard	1/2	1/2	1/2	1/2	1/2	1/2	1	1	1	1	1
Capacity	450 lbs	850 lbs	850 lbs	850 lbs	1,400 lbs	850 lbs	850 lbs	1,250 lbs	1,250 lbs	2,100 lbs	1,250 lbs
Color	Black	Black	Blue	Red	Black	Black	Black	Black	Red	Black	Black
Wheel	10" x 2.75"	10" x 2.75"	10" x 2.75"	10" x 2.75"	12" x 3"	12" x 3"	10" x 2.75"	12" x 3"	12" x 3"	12" x 3"	12" x 3"
Caster	(2) 4" x 1.5"	(2) 3" x 1.25"	(2) 3" x 1.25"	(2) 3" x 1.25"	(2) 4" x 2"	(1) 4" x 2"	(2) 4" x 1.25"	(2) 4" x 1.25"	(2) 4" x 1.25"	(2) 4" x 2"	(2) 4" x 2"

DIMENSIONS

	272575	272576	272577	272578	272579	272580	272581	272582	272583	272584	272585
A,B	60.75", 57"	61.5", 57"	61.5", 57"	61.5", 57"	61.5", 57"	61.5", 57"	72.5", 69"	72.75", 69"	72.75", 69"	72.75", 69"	73.75", 69"
C,D	21.5", 26.5"	21.5", 26.5"	21.5", 26.5"	21.5", 26.5"	21.5", 26.5"	21.5", 27"	24.5", 29.25"	24.5", 29.25"	24.5", 29.25"	24.5", 29.25"	24.5", 29.25"
E,F	18.75", 16"	18.75", 16"	18.75", 16"	18.75", 16"	18.75", 16"	18.75", 16"	22", 19.25"	22", 19.25"	22", 19.25"	22", 19.25"	22.5", 19.25"
G,H	29", 31"	29", 31"	29", 31"	29", 31"	29", 31"	29", 31"	37", 37"	37", 37"	37", 37"	37", 37"	37", 37"
Overall Height	36.5"	36.5"	36.5"	36.5"	37.5"	37.25"	43"	43"	43"	43.25"	43.5"
Weight	51 lbs	65.5 lbs	65.5 lbs	65.5 lbs	83.5 lbs	88 lbs	74 lbs	94.5 lbs	94.5 lbs	107.5 lbs	119 lbs



1/2 and 1 Cubic Yard Lids

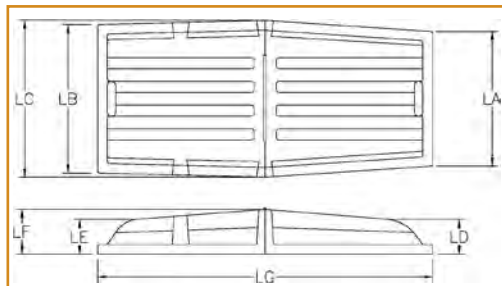

Lid Part #	272586	272587
Size	1/2 Cu. Yd.	1 Cu. Yd.
LA, LB, LC	24", 26.5", 28.375"	27.125", 29", 33.125"
LD, LE, LF, LG	6.5", 6.25", 7.5", 6.1"	6.625", 6.625", 8.25", 7.150"
Weight	11 lbs.	16.5 lbs

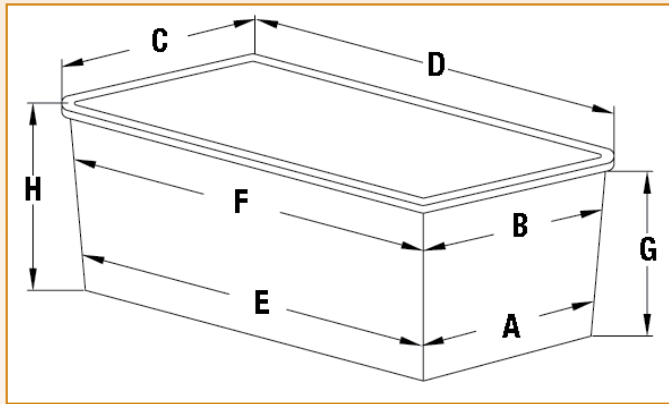

Standard
Caster
Pattern



OR
Diamond
Caster
Pattern



To order the diamond caster pattern, add DP to Part #. Example: 272513DP.



Look!
8" Pneumatic Casters

Plastic Box Trucks

- Material: polyethylene.
- Five sizes and color choices.
- Two caster choices: 5" Polyurethane or 8" Pneumatic. Two swivel, two rigid mounted on 5-Ply Plywood base for extra rigidity (except 4 bushel models).
- Can ship KD and nested on quantity orders.
- Caster pattern Standard or Diamond.
- White color, only, produced from FDA compliant polyethylene material.***

5" caster adds 6.75" to height, except 4 bushel adds 6"

8" caster adds 10.75" to height, except 4 bushel adds 10"

	32 gal. 4 bushels	64 gal. 8 bushels	96 gal. 12 bushels	128 gal. 16 bushels	160 gal. 20 bushels
Volume					
Capacity	350 lbs	450 lbs	550 lbs	600 lbs	600 lbs
Dimensions (inches): A-B-C-D E-F-G-H	17 - 17.75 - 20.75 - 32 27.75 - 29 - 13.75 - 15.25	19 - 21 - 24 - 35 30 - 31.75 - 21.5 - 23	22.75 - 25 - 28 - 38 33 - 35 - 27 - 28.25	24.25 - 27 - 30 - 42 36 - 38 - 28.25 - 29.75	28 - 30.75 - 34 - 46 39.75 - 43 - 31.25 - 33
Weight: Tub Only	10 lbs	16.5 lbs	25 lbs	33 lbs	42.5 lbs
Weight: Assembled Tub					
5" Caster	20 lbs	43 lbs	50 lbs	54 lbs	65 lbs
8" Caster	24 lbs	47 lbs	54 lbs	58 lbs	69 lbs
GREY Part #: 5" Caster	272503	272508	272513	272518	272523
8" Caster	272530	272531	272532	272533	272534
BLUE Part #: 5" Caster	272504	272509	272514	272519	272524
8" Caster	272535	272536	272537	272538	272539
* WHITE Part #: 5" Caster	272505	272510	272515	272520	272525
8" Caster	272540	272541	272542	272543	272544
RED Part #: 5" Caster	272506	272511	272516	272521	272526
8" Caster	272545	272546	272547	272548	272549
YELLOW Part #: 5" Caster	272507	272512	272517	272522	272527
8" Caster	272550	272551	272552	272553	272554

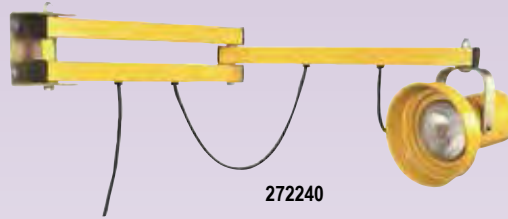

272240



Light with fan kit installed
272340

UL Approved Dock Lights

- Spring-loaded pushup socket for easy bulb changing.
- 7 gauge wall mount standard.
- 18" two speed fan accessory.
- Use with incandescent lamps or LED only: PAR-38: up to 150W. R40: up to 300W.
- For indoor use.
- Ready for hardwiring or plug attachment.
- 272328 & 272329 arm and fan only (NO LIGHT). Fan has a 62" long cord with a 3 prong plug. Fan plugs directly into outlet. No hard wiring or plug attachment required. On & Off switch on fan.

Part #	272224	272240	272260	272290	272330	272328	272329	272340	272360
Description	24" Light	40" Light	60" Light	90" Light	Fan only	Fan with 40" arm	Fan with 60" arm	Light & fan w/40" arm	Light & fan w/60" arm
Weight	15.5 lbs	17.7 lbs	22 lbs	31 lbs	20 lbs	41 lbs	45 lbs	38 lbs	39 lbs



272286

Universal Strapping Truck

- Automatic brake to reduce strap spillage.
- Tray for storing tools and seals.
- Handles steel and non-metallic strapping.
- Accepts 3", 6" and 8" face coils; 8" and 16" core sizes.
- 10" x 1.75" steel semi-pneumatic wheel.

OVERALL DIMENSIONS

w: 27"
h: 39"
d: 25"



272008



272009

Poly Strapping System

- Tools for tightening and sealing poly and plastic strap.
- High quality tensioner tightens and cuts .5" to .625" plastic strap.

BOXED OVERALL DIMENSIONS

w: 4.25"	4.25"	4.25"
h: 3"	1.5"	1.5"
d: 10.75"	17"	17"



272011



272024

Steel Strapping System

- Tools for tightening and sealing steel banding.
- Cast steel tensioner for most sizes (.375" to .75").

BOXED OVERALL DIMENSIONS

w: 4"	6.25"	6.25"	6.25"
h: 3.5"	1.75"	1.75"	1.75"
d: 15.5"	13.5"	13.5"	13.5"



272015

Strap Cutters

- One hand operation.

BOXED OVERALL DIMENSIONS

w: 1.75"
h: 1.75"
d: 12"



272022

Tensioner/ Crimper

- Push/windless type for steel strapping.
- With cutter and hammer knob for seal closing.
- For use with wing seals.
- Use for on .375" - .75" wide and up to .030" thick steel strap.

BOXED OVERALL DIMENSIONS

w: 4"
h: 2.5"
d: 12.75"

Part #	272286	272008	272009	272010	272011	272023	272024	272025	272015	272022
Description	Truck	Tensioner	Sealer	Sealer	Tensioner	Sealer	Sealer	Sealer	Deluxe	Tensioner/Crimper
Size	N/A	.375" - .75"	.5" only	.625" only	.375" - .75"	.375" only	.5" only	.75" only	up to .75"	.375" - .75"
Weight	54 lbs	3 lbs	4 lbs	4 lbs	5 lbs	2 lbs	2 lbs	2 lbs	2 lbs	3.25 lbs

WESCO® EASY MOUNT STRIP DOORS

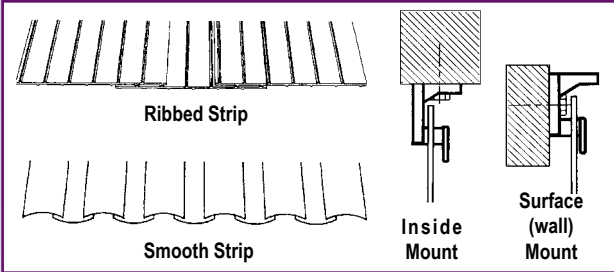

Note: Models and sizes shown are for inside mount. For outside or surface mount select next highest width and height or select size as required.

Easy Mount Strip Doors

- Molded plastic, high-strength, Easy-Mount Bracket. No bolts or screws, just hook it on.
- Energy conserving
- Reduces noise, dirt, dust and odors. Helps meet OSHA noise rules.
- Two-way visibility.
- No wasted space for swinging door.
- High quality flexible vinyl.



- Functional from -20° to 150° F as an effective thermal barrier. Special compound reduces bruising and lacerations and fading UV rays.
- Two styles: **Smooth** – concave/convex overlap for best seal in 12" and 8" widths. **Ribbed** – reduced scratching and improved sealing.
- Orange end panels on doors with 12" strips.
- 12" strips are .120 thick; 8" strips are .080" thick.
- Can be ordered as complete doors, individual strips, and bulk lengths.
- Custom sizes available.
- Note: The length of the strip is dependent on the type of mount used.
- 12 ft. maximum length.

HEAVY DUTY – 12" STRIP WIDTH 66% OVERLAP

WALK THROUGH DOORS – 8" STRIP WIDTH 50% OVERLAP

Opening W.x H.	Smooth Part #	Ribbed Part #	Opening W. x H.	Smooth Part #	Ribbed Part #
6' x 7'	272813	272863	3' x 7'	272801	N/A
6' x 8'	272814	272864	3' x 8'	272802	N/A
6' x 9'	272815	272865	4' x 7'	272803	N/A
6' x 10'	272816	272866	4' x 8'	272804	N/A
6' x 12'	272817	272867	5' x 7'	272805	N/A
7' x 7'	272818	272868	5' x 8'	272806	N/A
7' x 8'	272819	272869	6' x 7'	272807	N/A
7' x 9'	272820	272870	6' x 8'	272808	N/A
7' x 10'	272821	272871	7' x 7'	272809	N/A
7' x 12'	272822	272872	7' x 8'	272810	N/A
8' x 7'	272823	272873	8' x 7'	272811	N/A
8' x 8'	272824	272874	8' x 8'	272812	N/A
8' x 9'	272825	272875	REPLACEMENT STRIPS – CLEAR		
8' x 10'	272826	272876	Size	Smooth Part #	Ribbed Part #
8' x 12'	272827	272877	8" x 7"	171001	N/A
9' x 7'	272828	272878	8" x 8"	171002	N/A
9' x 8'	272829	272879	12" x 7"	171003	171012
9' x 9'	272830	272880	12" x 8"	171004	171013
9' x 10'	272831	272881	12" x 9"	171005	171014
9' x 12'	272832	272882	12" x 10'	171006	171015
10' x 7'	272833	272883	12" x 12'	171007	171016
10' x 8'	272834	272884	REPLACEMENT STRIPS – ORANGE		
10' x 9'	272835	272885	Size	Smooth Part #	Ribbed Part #
10' x 10'	272836	272886	12" x 7"	171022	171032
10' x 12'	272837	272887	12" x 8"	171023	171033
12' x 7'	272838	272888	12" x 9"	171024	171034
12' x 8'	272839	272889	12" x 10'	171025	171035
12' x 9'	272840	272890	12" x 12'	171026	171036
12' x 10'	272841	272891	BULK STRIP – ORDER BY THE FOOT		
12' x 12'	272842	272892	Color/ Width	Smooth Part #	Ribbed Part #
14' x 7'	272843	272893	Clear 8"	172003	N/A
14' x 8'	272844	272894	Clear 12"	172004	172006
14' x 9'	272845	272895	Orange 12"	172005	172007
14' x 10'	272846	272896	REPLACEMENT HANGERS		
14' x 12'	272847	272897	Length	Part #	
			24"	172001	

DOCK/SHIPPING EQUIPMENT/SHELVING/WHEELS

WESCO® CHROME-PLATED WIRE SHELVING

Features:

- Open wire design that provides maximum visibility and air circulation while minimizing dust accumulation.
- All units are NSF® Approved for use in the food industry.
- Sets up easily without tools.
- Shelves adjust at 1" increments on numbered posts.
- Adjustable floor levelers compensate for surface irregularities.
- Begin with "starter" units and then "add-on" additional units.
- Not suitable for refrigerated or freezer cold storage environments.
- Capacity of wire shelving sets are reduced to 880 lbs. when using Wesco caster sets. All capacities based upon evenly distributed loads.



Wire Shelving Starter Unit

- Kit consists of 4 posts, 4 shelves and 16 post sleeves that secure shelves to posts.
- Posts are numbered around diameter in 1" increments.
- 24 sizes to choose from: shelves available in 18" and 24" depth and 36", 48", 60", and 72" length; posts are available in 63", 74", and 86" heights.



Add-On Kit

- Kit consists of 2 posts, 4 shelves, 8 "S" hooks and 8 post sleeves that secure shelves to posts.
- "S" hooks attach Add-on Kits to existing shelving units.
- 24 sizes to choose from: shelves available in 18" and 24" depth, and 36", 48", 60", and 72" length; posts are available in 63", 74", and 86" heights.

STARTER UNITS

ADD-ON KITS

Part #	Size (D x W x H)	Total Unit Capacity*	Capacity Per Shelf*	Part #	Size (D x W x H)	Total Unit Capacity*	Capacity Per Shelf*
272640	18" x 36" x 63"	2,400 lbs	600 lbs	272646	18" x 36" x 63"	2,400 lbs	600 lbs
272641	18" x 36" x 74"	2,400 lbs	600 lbs	272647	18" x 36" x 74"	2,400 lbs	600 lbs
272642	18" x 36" x 86"	2,400 lbs	600 lbs	272648	18" x 36" x 86"	2,400 lbs	600 lbs
272703	18" x 48" x 63"	2,400 lbs	600 lbs	272721	18" x 48" x 63"	2,400 lbs	600 lbs
272704	18" x 48" x 74"	2,400 lbs	600 lbs	272722	18" x 48" x 74"	2,400 lbs	600 lbs
272705	18" x 48" x 86"	2,400 lbs	600 lbs	272723	18" x 48" x 86"	2,400 lbs	600 lbs
272706	18" x 60" x 63"	2,400 lbs	600 lbs	272724	18" x 60" x 63"	2,400 lbs	600 lbs
272707	18" x 60" x 74"	2,400 lbs	600 lbs	272725	18" x 60" x 74"	2,400 lbs	600 lbs
272708	18" x 60" x 86"	2,400 lbs	600 lbs	272726	18" x 60" x 86"	2,400 lbs	600 lbs
272709	18" x 72" x 63"	2,000 lbs	500 lbs	272727	18" x 72" x 63"	2,000 lbs	500 lbs
272710	18" x 72" x 74"	2,000 lbs	500 lbs	272728	18" x 72" x 74"	2,000 lbs	500 lbs
272711	18" x 72" x 86"	2,000 lbs	500 lbs	272729	18" x 72" x 86"	2,000 lbs	500 lbs
272643	24" x 36" x 63"	2,400 lbs	600 lbs	272649	24" x 36" x 63"	2,400 lbs	600 lbs
272644	24" x 36" x 74"	2,400 lbs	600 lbs	272650	24" x 36" x 74"	2,400 lbs	600 lbs
272645	24" x 36" x 86"	2,400 lbs	600 lbs	272651	24" x 36" x 86"	2,400 lbs	600 lbs
272712	24" x 48" x 63"	2,400 lbs	600 lbs	272730	24" x 48" x 63"	2,400 lbs	600 lbs
272713	24" x 48" x 74"	2,400 lbs	600 lbs	272731	24" x 48" x 74"	2,400 lbs	600 lbs
272714	24" x 48" x 86"	2,400 lbs	600 lbs	272732	24" x 48" x 86"	2,400 lbs	600 lbs
272715	24" x 60" x 63"	2,400 lbs	600 lbs	272733	24" x 60" x 63"	2,400 lbs	600 lbs
272716	24" x 60" x 74"	2,400 lbs	600 lbs	272734	24" x 60" x 74"	2,400 lbs	600 lbs
272717	24" x 60" x 86"	2,400 lbs	600 lbs	272735	24" x 60" x 86"	2,400 lbs	600 lbs
272718	24" x 72" x 63"	2,000 lbs	500 lbs	272737	24" x 72" x 63"	2,000 lbs	500 lbs
272719	24" x 72" x 74"	2,000 lbs	500 lbs	272738	24" x 72" x 74"	2,000 lbs	500 lbs
272720	24" x 72" x 86"	2,000 lbs	500 lbs	272739	24" x 72" x 86"	2,000 lbs	500 lbs

*Capacity in pounds based on evenly distributed loads.

Accessories for Wire Shelving

- 5" x 1.25" stem casters. Choice of polyurethane or rubber wheels.
- Foot plates to bolt racks to the floor.
- Shelf edges to prevent items from falling.
- Extra shelves sold in pairs only.
- Leveling feet protect flooring and level racks on uneven surfaces.
- Post clamps join units together and "S" hooks are needed when adding shelves.
- Snap in 8" high shelf dividers keep shelves organized.
- Replacement posts sold in pairs only.



Shelf Sets

2 Shelves/Set

OVERALL DIMENSIONS

w:	36"	48"	60"	72"	36"	48"	60"	72"
h:	1.3"	1.3"	1.3"	1.3"	1.3"	1.3"	1.3"	1.3"
d:	18"	18"	18"	18"	24"	24"	24"	24"

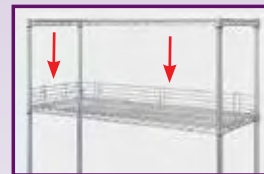

Shelf Edges

OVERALL DIMENSIONS

w:	18"	24"	36"	48"	60"	72"
h:	3"	3"	3"	3"	3"	3"
d:	.25"	.25"	.25"	.25"	.25"	.25"

Part #	170278	170264	170265	170266	170279	170267	170268	170269	170247	170248	170273	170249	170251	170252
Description	(2) 18" x 36" shelves	(2) 18" x 48" shelves	(2) 18" x 60" shelves	(2) 18" x 72" shelf	(2) 24" x 36" shelf	(2) 24" x 48" shelves	(2) 24" x 60" shelves	(2) 24" x 72" shelves	18" shelf edge	24" shelf edge	36" shelf edge	48" shelf edge	60" shelf edge	72" shelf edge
Weight	21 lbs	26.2 lbs	32 lbs	43 lbs	29 lbs	37 lbs	48 lbs	56.5 lbs	2 lbs	2.4 lbs	2.5 lbs	2.76 lbs	4 lbs	4 lbs



Shelf Dividers

Shelf Post Sets

2 Posts/Set



Caster Sets

- 4 swivel casters per set. 2 with brakes; 2 without.
- Wire shelving sets with Wesco casters have a maximum capacity of 880 lbs. with an evenly distributed load.



Leveling Feet



"S" Hooks



Post Clamps

Part #	170253	170254	170261	170262	170263	170258	170270	170256	170255	170260
Description	18" W 8" H	24" W 8" H	(2) 63" long	(2) 74" long	(2) 86" long	5" Rubber wheels A. 8.625" B. 6.437"	5" Polyurethane wheels A. 8.562" B. 6.375"	A. .50"		
Weight	1.75 lbs	2.4 lbs	7 lbs	9 lbs	10 lbs	11.25 lbs	10 lbs	.31 lb	.05 lb	1 lb



Foot Plates



Replacement Sleeves

Part #	170257	170259
Weight	.15 lb	.11 lbs

Trailer Stabilizing Jacks

- High strength steel construction.
- Adjustable height for leveling of trailers parked on uneven ground.
- Broad base prevents trailer dollies from sinking into soft surfaces.
- Prevents up-ending of semi-trailers when not connected to a truck during loading/unloading.
- **TSJE Economy**, manually turned ACME threaded screw raises and lowers jack. 14" dia. base, 5" x 5" top plate.
- **TSJS Standard**, ratchet with ACME threaded screw raises and lowers jack. 14" diameter x 1/2" thick base plate, 8" semi-pneumatic wheels, 8" diameter top plate.
- **TSJHD Heavy duty**, two way reversible hand ratchet, 6" x 24" long beam, 5" triangular base, 8" semi-pneumatic wheels, and 4" semi-steel wheels.
- **Wesco recommends always using at least two jacks per trailer. Meets OSHA requirements.**



272957



272955



272956

OVERALL DIMENSIONS

w:	13.75"	13.75"	14.5"
h:	44"-51"	39.5" - 51"	39.5" - 51"
d:	13.75"	13.75"	26.5"

Part #	272957	272955	272956
Model #	TSJE	TSJS	TSJHD
Static Capacity	50,000 lbs	100,000 lbs	100,000 lbs
Lifting Capacity	5,000 lbs	40,000 lbs	50,000 lbs
Service Range	44" - 51"	39.5" - 51"	39.5" - 51"
Weight	45 lbs	125 lbs	160 lbs



Cargo Bars, Hoops and Decking Beams

- Helps secure loads to prevent shifting.
- One or two piece construction.
- Materials of construction are lightweight aluminum and heavy duty steel.
- **#272962 optional hoops available for models #272958 and #272961 only.**
- Cargo bars with quick release feature.



272962 HOOPS

OVERALL DIMENSIONS

w:	1.5" dia.	1.5"	1.75"	1.5"	24" W x 36" L	2.625"	2.625"
h:		1.5"	1.75"	1.5"		3.1875"	3.1875"
l:	87" - 103"	87" - 115"	64" - 130"	82.5" - 110"		91" - 102"	91" - 102"

Part #	272958	272959	272960	272961	272962	273130	273138
Model #	CBA1000	CBS2000	CBGS3000	CBS4000	CBHOOP	E-TRACK DECKING BEAM	E-TRACK DECKING BEAM
Static Capacity	N/A	N/A	N/A	N/A	N/A	2,000 lbs	3,000 lbs
Length Adjustment	87" - 103"	87" - 116"	80" - 139"	86" - 115"	N/A	91" - 102"	91" - 102"
Articulating Foot Pads	4" x 2.5"	4" x 4"	4" x 4"	4" x 4"	N/A	E-track clips	E-track clips
Construction	Aluminum Round Tube	Galvanized Sq. Steel Tube	Galvanized Sq. Steel Tube	Galvanized Steel	Galvanized Steel	Aluminum & zinc-plated steel	Aluminum & zinc-plated steel
Weight	11 lbs	18 lbs	24 lbs	17 lbs	15 lbs	22 lbs	24 lbs

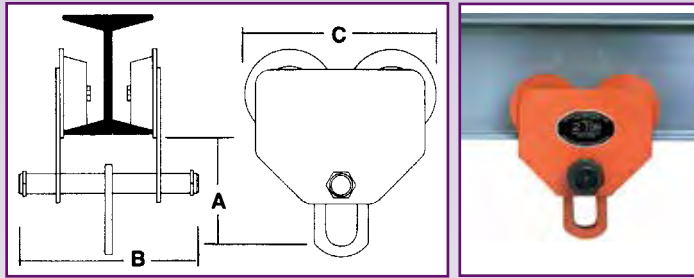

272159

Wesco Trolleys

- Heavy duty trolleys designed for flexibility of installation.
- Usable on straight or curved track.
- Adjusts for wide variety of beam widths; simply remove end nut and adjust spacers.
- Can be installed or removed from any point in the track.

Part #	272158	272159	272160	272161	272162
Capacity	1,000 lbs	2,000 lbs	4,000 lbs	6,000 lbs	10,000 lbs
Fits I-Beam Flange Width	3.5" to 5.5"	3.5" to 5.875"	4.125" to 7"	4" to 7"	5" to 7"
A	4"	5"	5.75"	6.75"	7.75"
B	10.25"	12.5"	13.25"	14"	14.625"
C	7.875"	9.5"	11.375"	13.25"	15.375"
Weight	18 lbs	31 lbs	48 lbs	76 lbs	104 lbs

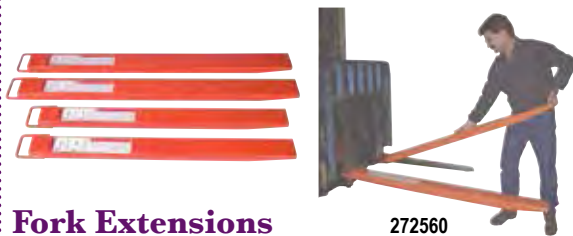

272560

Fork Extensions

- Heavy duty welded steel construction.
- Steel restraining strap prevents extensions from sliding off fork.
- Sold in pairs.
- Maximum lift truck fork thickness 2".

NOTES:

1. OSHA requires contacting the manufacturer of your fork truck for written approval for the use of any fork truck attachment.
2. OSHA standards require that the length of fork extensions do not exceed the lift truck fork length by more than 50%. (e.g., Fork extension used on 48" long lift truck forks should not exceed 72".)
3. The use of extensions effect lift truck capacity. Contact lift truck manufacturer for load capacity reductions.

	OVERALL DIMENSIONS				
w:	6.75"	6.75"	7.75"	7.75"	8.75"
h:	2.375"	2.375"	2.375"	2.375"	2.375"
d:	63.375"	75.375"	63.375"	75.375"	75.375"

Part #	272558	272559	272560	272561	272562
Capacity	N/A	N/A	N/A	N/A	N/A
Size	4" x 60"	4" x 72"	5" x 60"	5" x 72"	6" x 72"
Fits Fork Width	4"	4"	5"	5"	6"
Weight	95 lbs	114 lbs	108 lbs	121 lbs	139 lbs

Battery Transfer Cart

- For use with a standard pallet truck (sold separately).
- Pallet trucks easily locate in 6.75" W x 3.5" H fork pockets.
- One person can easily remove and replace forklift batteries.
- (12) 2.25" diameter steel rollers.
- Swing tabs help to hold battery in place while on rollers.
- Winch with 2" wide nylon belt and safety latch hook.
- Height to top of rollers 6.5".
- Platform roller base:
I.D. 26.75" W x 43.25" L.
O.D. 27.25" W x 43.625" L.
- Adjustable winch height:
Lowered - 29.625".
Raised - 35.50".



OVERALL DIMENSIONS

w: 27.25"
h: 41.50"
d: 55.875"

Part #	274260
Model #	BAT-TC
Capacity	4,000 lbs
W x L	26.75" W x 43.25" L (usable deck)
Weight	131 lbs



272571

Foldable Maintenance Platform

- (4) swivel casters - 4" x 1.5" moldon polyurethane.
- Fork Pockets: 7.75"W x 3.5"H. Centers: 26".
- Replacement **caster set #272572**, 13.2 lbs.

	OVERALL DIMENSIONS
w:	37.5"
h:	81" w/o casters; 87.25" w/casters
d:	42.25"

Part #	272571
Capacity	600 lbs
Size	Platform Deck - 37" x 37" I.D.
Fits Fork Width	N/A
Weight	220 lbs

Cellular Foam Wheel / Microcellular Polyurethane – will not go flat



CF

Part No.	Model	Diameter	Hub Type	Tread Width	Hub Length	Bore Id	Approx. Weight	Bearing Type	Capacity Lbs.
053446	CF	10"	Steel	3"	2.25"	.625"	5 LBS.	BALL	280
053490	CFB	10"	Steel	3"	2.25"	.75"	5 LBS.	BALL	280

Solid Rubber Wheels



Z2

Part No.	Model	Diameter	Hub Type	Tread Width	Hub Length	Bore Id	Approx. Weight	Bearing Type	Capacity Lbs.
150698	Z2	10"	Poly	2.75"	2.25"	.625"	5 LBS. 12 OZ.	BALL	550
150697	Z8	8"	Poly	2.0"	2.25"	.625"	3.5 LBS.	BALL	300
108479	SR	10"	Poly	2.5"	2.25"	.625"	9 LBS.	BALL	250
109486	Z-12	12"	Poly	3"	3.25"	.625"	8 LBS.	BALL	750

Semi-Pneumatic Wheels



Z

Part No.	Model	Diameter	Hub Type	Tread Width	Hub Length	Bore Id	Approx. Weight	Bearing Type	Capacity Lbs.
052859	Z8B	8"	Poly	2.5"	2"	.75"	4.25 Lbs.	Ball	250
150589	Z	10"	Zinc/Steel	2.75"	2.25"	.625"	6.25 Lbs.	Ball	350

Pneumatic Wheels



P

Part No.	Model	Diameter	Hub Type	Tread Width	Hub Length	Bore Id	Approx. Weight	Bearing Type	Capacity Lbs.
050602	P	10"	Zinc/Steel	3.50"	2.25"	.625"	4 LBS.	BALL	350
108478	PB	10"	Zinc/Steel	3.50"	2.25"	.75"	4 LBS.	BALL	350
108484	P-12	12"	Zinc/Steel	4"	3.25"	.75"	7 LBS.	BALL	460
151507	PWT	10"	Zinc/Steel	3.625"	2.25"	.625"	4 LBS.	BALL	350
151551	PE	10"	Zinc/Steel	3.50"	2.25"	.625"	3.5 LBS.	BALL	350

Aluminum Center Moldon Rubber Wheels



R

Typical aluminum center moldon wheel



R3

Part No.	Model	Diameter	Hub Type	Tread Width	Hub Length	Bore Id	Approx. Weight	Bearing Type	Capacity Lbs.
050567	A	6"	Solid	2"	2.375"	.625"	2.5 LBS.	BALL	500
053706	AB	6"	Solid	2"	2.1875"	.625"	2.5 LBS.	ROLLER	500
053707	-	6"	Solid	2"	2.1875"	.75"	2.5 LBS.	ROLLER	500
052870	RB	8"	Solid	1.625"	2"	.75"	3 LBS.	BALL	500
108545	R	8"	Solid	1.625"	2"	.625"	3 LBS.	BALL	500
052868	H-1B	8"	Solid	2"	2.25"	.75"	3.75 LBS.	BALL	550
053708	H-1R	8"	Solid	2"	2.1875"	.625"	3.75 LBS.	ROLLER	600
150131	H-1RB	8"	Solid	2"	2.1875"	.75"	3.75 LBS.	ROLLER	600
108561	R3	8"	Spoke	1.625"	1.625"	.625"	2.5 LBS.	BALL	300

Balloon Cushion TPR Rubber



BC-10

Part No.	Model	Diameter	Tread Width	Hub Length	Bore Id	Approx. Weight	Bearing Type	Capacity Lbs.	Hub Type
*150228	BC-10	10"	2.165"	2.25"	.625"	4 LBS. 12 OZ.	BALL	300	Polyolefin
*150229	BC-8	8"	2.165"	2.25"	.625"	2 LBS. 12 OZ.	BALL	300	Polyolefin
050566	RK-8	8"	2.25"	2.25"	.750"	3 LBS. 10 OZ.	BALL	450	Aluminum

* BC-8 is gray non-marking TPR rubber. BC-10 is charcoal-gray non-marking TPR rubber.

Moldon Rubber on Cast Iron Hubs



BT

Part No.	Model	Diameter	Tread Width	Hub Length	Bore Id	Approx. Weight	Bearing Type	Capacity Lbs.
053722	-	5"	2"	2.1875"	.75"	3.25 LBS.	ROLLER	500
108838	-	6"	1.5"	2"	.75"	3.50 LBS.	BALL	400
108839	-	6"	1.5"	2"	.625"	3.50 LBS.	BALL	400
053723	-	6"	2"	2.1875"	.625"	4.25 LBS.	ROLLER	500
053724	-	6"	2"	2.1875"	.75"	4.25 LBS.	ROLLER	500
050579	H	8"	2"	2.1875"	.625"	6.25 LBS.	ROLLER	600
150120	HB	8"	2"	2.1875"	.75"	6.25 LBS.	ROLLER	600
150596	BT	10"	2.5"	2.75"	1.00"	13.75 LBS.	ROLLER	800

Moldon Polyurethane on Polypropylene Hub



Part No.	Model	Diameter	Tread Width	Hub Length	Bore Id	Approx. Weight	Bearing Type	Capacity Lbs.
053730	PP10	10"	2.5"	2.75"	1.00"	6 LBS.	ROLLER	1200
053733	PP8	8"	2"	2.1875"	.75"	2.5 LBS.	BALL	800

Moldon Rubber on Polyolefin Hub



R2

Part No.	Model	Diameter	Tread Width	Hub Length	Bore Id	Approx. Weight	Bearing Type	Capacity Lbs.
150692	R2	8"	1.625"	2.187"	.625"	1 LB.	PLAIN	375

Solid Polyolefin Wheels



BTW

Part No.	Model	Diameter	Tread Width	Hub Length	Bore Id	Approx. Weight	Bearing Type	Capacity Lbs.
150103	CWP-1	2.5"	1.125"	1.25"	.5"	2.5 OZ.	PLAIN	200
150197	-	3"	1.25"	1.56"	.375"	3 OZ.	PLAIN	300
101355	-	4"	1.25"	1.56"	.5"	5 OZ.	PLAIN	350
108300	CT-3	5"	1.5"	1.62"	.5"	8 OZ.	PLAIN	400
150693	E-2	6"	1.5"	1.625"	.625"	13 OZ.	PLAIN	500
150204	-	8"	2"	2.25"	.75"	2 LBS.	PLAIN	600
150691	BTW	10"	2.25"	2.75"	1.00"	2.5 LBS.	PLAIN	750

Solid Phenolic Resin Wheels



Part No.	Model	Diameter	Tread Width	Hub Length	Bore Id	Approx. Weight	Bearing Type	Capacity Lbs.
053902	-	5"	2"	2.1875"	.625"	1.75 LBS.	ROLLER	1000
053769	-	5"	2"	2.1875"	.75"	1.75 LBS.	ROLLER	1000
053903	-	6"	2"	2.1875"	.625"	2.5 LBS.	ROLLER	1200
053770	-	6"	2"	2.1875"	.75"	2.5 LBS.	ROLLER	1200

Phenolic resin wheels are non-marking.

NEW!

PRODUCTS FROM WESCO®



4-Wheel Drum Cart
#210353 - 10" wheel
#210354 - 8" wheel
Page 6.



STAINLESS STEEL
Stainless Steel
Rotary
Drum Pump
#272397, Page 20.



Pneumatic Power Leveler
#272696, Page 78.



Double Scissors
Lift Table
#272862,
Page 75.



STAINLESS STEEL
Stainless Steel Carts
3 Shelf Carts, 5 Models,
Page 89.



Premium
Light Duty Winch Lift
#274520, Page 62.



Powered Lift Scissors Tables
#273710 (660 lb. Capacity)
#273711 (1,100 lb. Capacity)
#273712 (1,650 lb. Capacity), Page 77.



Powered Lift Double
Scissors Table
#273713 (770 lb.
Capacity), Page 77.

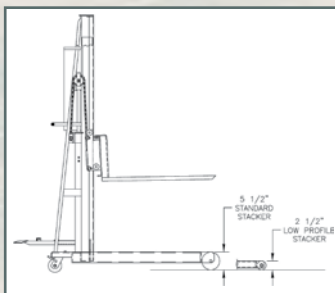

Low Profile Stacker
Outrigger Option, Page 60.



80" Long Deck Scissors Table
#273230 (2,200 lb. Capacity),
Page 76.



Powered Pallet Truck Stacker
#273129, Page 52.



PRODUCTS FROM WESCO®



MADE IN THE USA
Stainless Steel
Universal Drum Lifter
Part #240063, Page 11.



Stainless Steel
Drum Dolly
Part #240197, Page 7.



MADE IN THE USA
Stainless Steel
Hand Truck
Part #210351, Page 22.



MADE IN THE USA
Stainless Steel
Drum / Hand Truck
Part #210352, Pages 6 & 26.



Stainless Steel
Heavy-Duty Faucet
Part# 272038, Page 17.



MADE IN THE USA
Stainless Steel Knock-
Down Drum Truck
Part #240019, Page 5.



MADE IN THE USA
Stainless Steel
Drum Handler
Part #240240,
Page 15.

NEW!



Stainless Steel
Rotary Drum Pump
#272397, Page 20.



Stainless Steel
Electric High Lift
Part #272860,
Page 51.



MADE IN THE USA
Stainless Steel
4-Wheeled Pedalift
Part #260197, Page 56.



MADE IN THE USA
Stainless Steel
4-Wheeled Pedalift
Part #260186, Page 56.



NEW!
Stainless Steel Carts
3 Shelf Carts, 5 Models,
Page 89.



Stainless Steel Pallet Truck
Part #272152, Page 49.



Stainless Steel Folding
Handle Truck
Part #270458, Page 87.



Stainless Steel
Manual High Lift
Part #272859, Page 51.

