

RiveTier® I

Assembly Instructions RiveTier 1 Long Span Shelving

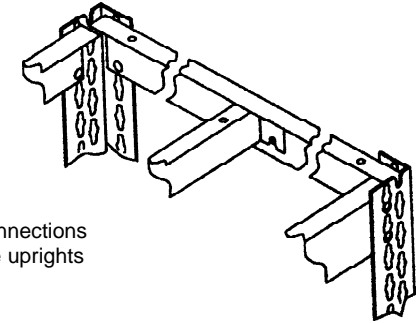

All rivet connections from inside uprights

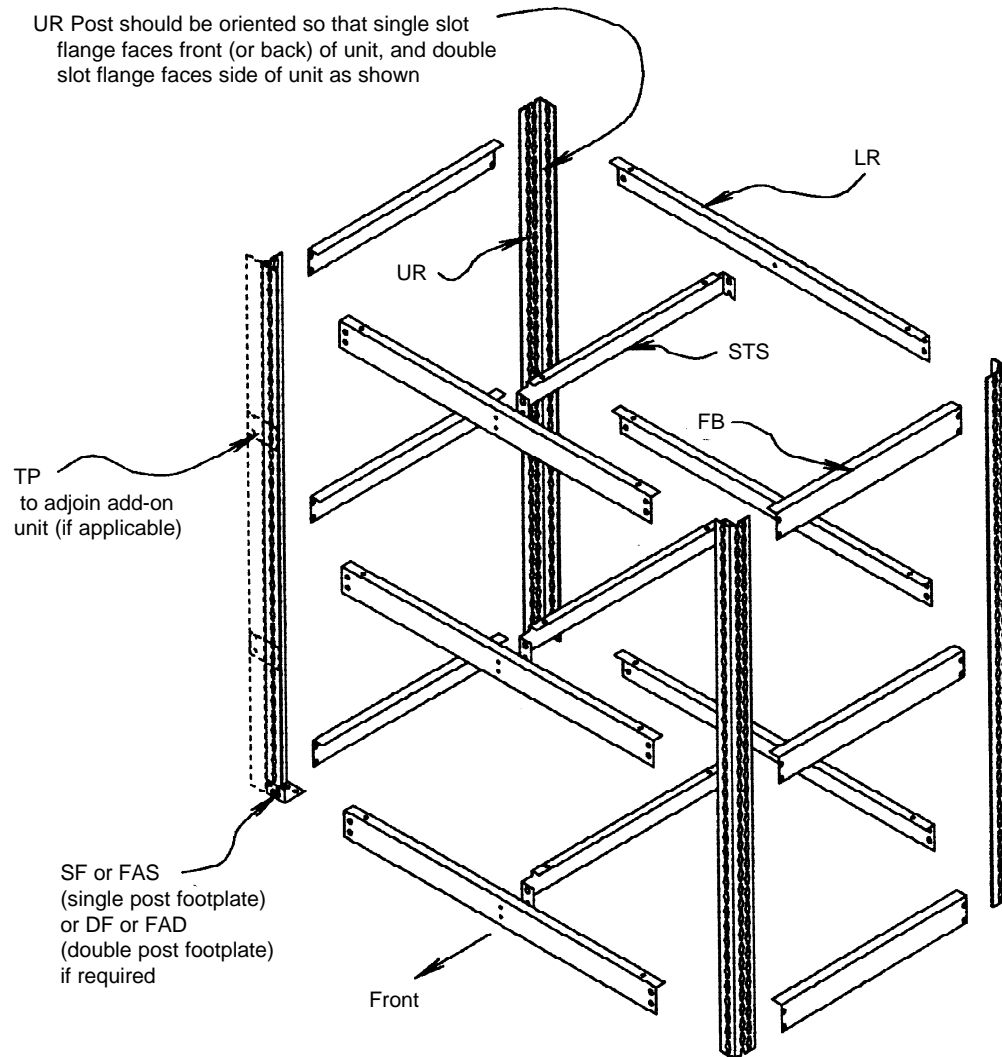
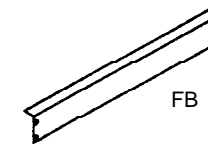

FB member is 2-5/16" shorter than nominal length with rivets located 1/4" from end

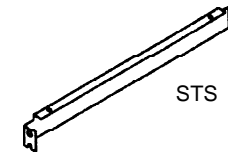

STS required on heavy duty units only. Optional on all other units 42" and over in width.

LR members 42" through 84" wide have 1 pair of STS rivets at the center line. 96" members have 2 pair of STS rivets.

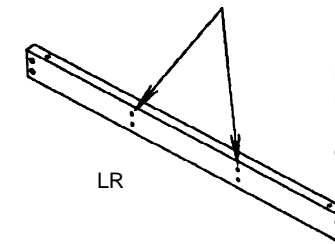

LR member actual length is same as nominal length with rivets located 5/8" from end.

NOTES

- Particle board not shown for clarity. For ease of installation, shorter depth units should be assembled from the bottom up, inserting particle board as each shelf level is assembled.
- Rivets on beams insert into key slots on posts. Beam must be hit firmly with mallet to seat rivets properly.
- Bottom beam level to be 3" max. from ground level.

7004-02.01

 **Western Pacific Storage Systems**

© 2001 Western Pacific Storage Systems