

# PARTS, INSTALLATION AND MAINTENANCE MANUAL for 4 CUP VACUUM ERGONOMIC HANDLING SYSTEM



**READ THIS MANUAL BEFORE USING THESE PRODUCTS.** This manual contains important safety, installation, and maintenance information. Make this manual available to all persons responsible for the installation, operation and maintenance of these products.

## **WARNING**

**Do not use this Handling Device for lifting, supporting, or transporting people. Do not use the system to lift or support loads over people. Always operate, inspect and maintain this equipment in accordance with applicable safety codes and regulations.**

**Equipment shown in this manual is intended for industrial use only. Use only Ingersoll-Rand components in installation. All Ingersoll-Rand components are tested and certified to applicable safety standards.**

## CONTENTS

<b>Description</b>	<b>Page No.</b>	<b>Description</b>	<b>Page No.</b>
Safety Information	3	Interlock Test	5
Danger, Caution, Warning and Notice	3	System Troubleshooting	6
Safety Summary	3	Preventative Maintenance	7
General Handling System Information	4	Air Supply	7
Principles of Balancer Operation	4	Wire Rope and Hook	7
Specifications	4	Controls, Hose, Tube and Pipe	7
Controls Operation	5	Handling Device	7
Interlock System (Safety Circuit)	5	Support System	7
Custom End Effector Operation	5	General Maintenance	7
Controls Installation	5	Parts Drawing and Parts List	8-13
Vacuum Interlock Adjustments	5	Warranty	15

## SAFETY INFORMATION

This manual provides instruction for the operation and maintenance of your **Ingersoll-Rand** Handling Device System. This manual supports a fully installed system. Operators should be familiar with the operation of the controls before using the system.

### Danger, Warning, Caution and Notice

Throughout this manual there are steps and procedures which, if not followed, may result in a hazard. The following signal words are used to identify the level of potential hazard.

 **DANGER** Indicates an imminently hazardous situation which, if not avoided, will result in death or serious injury.

 **WARNING** Indicates a potentially hazardous situation which, if not avoided, could result in death or serious injury.

 **CAUTION** Indicates a potentially hazardous situation which, if not avoided, may result in minor or moderate injury or property damage.

**NOTICE** Indicates information or a company policy that relates directly or indirectly to the safety of personnel or protection of property.

### Safety Summary

#### **WARNING**

- **Noncompliance, either in full or in part, with the operational directions marked with this symbol can result in injury, property or material damage. Danger, Warning and Caution notices must be strictly adhered to.**

#### **CAUTION**

- **The manufacturer has attempted to detail in this manual all areas of possible danger to personnel concerning the use of this equipment. However, personnel should use caution when installing, commissioning, adjusting, operating, and servicing this equipment.**
- **The manufacturer is not liable for any damage or injury arising from a workers failure to follow the instructions contained in this manual and failure to exercise due care and caution in the adjustment, installation, operation, service of this equipment. The following safety information should be carefully read and followed.**
- **Personal protective and safety equipment required by the operator's surrounding environment must be used and maintained in accordance with the manufacturer's instruction.**

#### **NOTICE**

- **The Custom End Effector will be referred to as the H/D (Handling Device) throughout this document.**

**Ingersoll-Rand** recognizes that most companies who use **Ingersoll-Rand** H/D Systems have a safety program in force at their facility. In the event that some conflict exists between a rule set forth in this publication and a similar rule already set by an individual company, the more stringent of the two should take precedence.

Safe Operating Instructions are provided to make an operator aware of dangerous practices to avoid and are not necessarily limited to the following list. Refer to specific sections in the manual for additional safety information.

1. Only allow personnel trained in safety and operation of this rail system to operate and maintain this system.
2. When a “**DO NOT OPERATE**” sign is placed on the H/D, do not use until repairs or adjustments have been completed and the sign has been removed by designated personnel.
3. Before each shift, visually check the H/D for wear and damage. Never use a H/D that inspection indicates is worn or damaged.
4. Check interlock circuit at first operation of the day.
5. Never exceed the rated capacity of the H/D. Refer to labels attached to the H/D.
6. Pay attention to loads suspended from the H/D at all times.
7. Make sure everyone is clear of the load path. Do not lift a load over people.
8. Use good posture when operating H/D.
9. Do not swing a suspended load.
10. Check air connections for leakage.
11. Never suspend a load for an extended period of time.
12. Never leave a suspended load unattended.
13. Never weld or cut a load suspended from the H/D.
14. Do not operate H/D if jamming, overloading, or binding occurs.
15. Avoid collision or bumping of suspended components on the H/D.

#### **WARNING**

- **If the part(s) is not held securely by the H/D and slips off the vacuum cups, the empty H/D will rise rapidly with the approximate force required to support the H/D and part(s).**
- **If system air pressure is lost, lower the H/D immediately. The operator must stay out of the vertical path of the H/D and part(s). The vacuum may lose the force required to hold the part(s) resulting in injury.**

## GENERAL HANDLING SYSTEM INFORMATION

**Ingersoll-Rand** H/D Systems are a group of engineered components designed to maximize the interaction between man and machine. The H/D mounts to a **Ingersoll-Rand** support system, articulating arm, balancer, jib crane, or aluminum and steel rail system. The balancer has a wire rope with load hook attached to a H/D that is used to lift and manipulate the part(s). The operator controls the system by using the up/down, and vacuum controls mounted on the H/D.

The system renders the part(s) weightless through its unique compressed air balancer. The support system provides easy horizontal movement, which creates a package that requires little physical effort reducing operator fatigue.

Suspended part(s) can be moved left or right, forward or back, for a predetermined distance, from a pick up point to a set down point. The suspended part(s) can be raised or lowered approximately twelve inches (300 mm) from which it has been raised by gently nudging the load up or down. This is known as floating. Use of the controls is not required for this, just pressure applied to the H/D and parts by the operator in the desired direction.

This manual provides necessary information for the **Ingersoll-Rand** Ergonomic Handling System.

While its scope cannot be complete unless addressing a specific system in a specific environment, it provides the installer and operator a clearer picture of the systems that can be assembled with **Ingersoll-Rand** equipment and accessories.

### Principles of Balancer Operation

The power source for the balancer is compressed air. A minimum of 70 psi (4.8 bar) is recommended, 100 psi (6.9 bar) maximum. The balancer reaches maximum capacity when 100 psi (6.9 bar) is applied, as air pressure decreases the unit capacity decreases proportionally. If 80 psi (5.5 bar) is applied to the balancer you will obtain 80% of rated capacity.

For a detailed principle of operation, see the **Ingersoll-Rand** Balancer Service Manual Form MHD56151.

## SPECIFICATIONS

5 inch x 7 inch Vacuum Cup Configuration

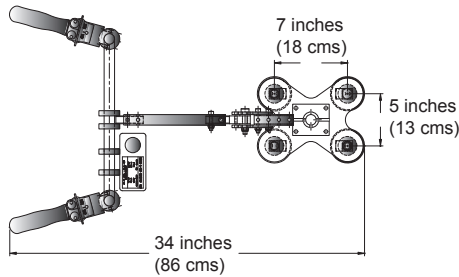

10 inch x 14 inch Vacuum Cup Configuration

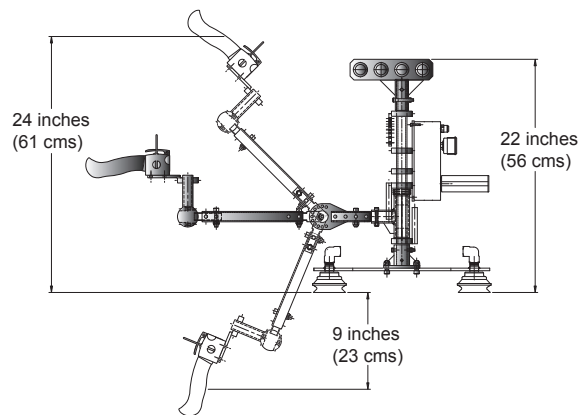
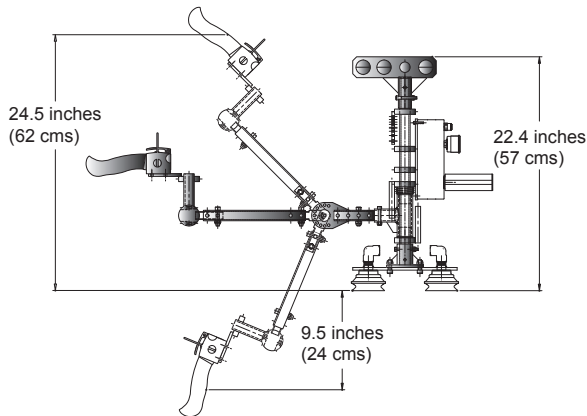
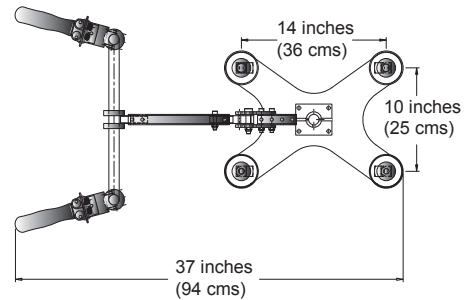

(Dwg. MHP2708)

## CONTROLS OPERATION

The ZA control package utilizes a pendant mounted to the H/D for up and down control. A manifold mounted on the balancer, controls the speed of the unit.

### Interlock System (Safety Circuit)

**Ingersoll-Rand's** Interlock is a pilot operated, adjustable spring return valve. Pilot pressure from the balancer shifts the valve when a load greater than that of the empty H/D is lifted. The Interlock is available on ZA controlled H/Ds only. When the interlock valve is shifted, the vacuum off circuit is disabled, to prevent accidentally dropping the suspended part(s). When the load is set down the pilot pressure from the balancer is reduced. The valve will shift to its original state allowing the vacuum off circuit to function and the part(s) to be released. The following warnings and operating instructions are intended to avoid unsafe operating practices which might lead to injury or property damage.

### Custom End Effector Operation

#### WARNING

- If the part(s) is not held securely by the H/D and slips off the vacuum cups, the empty H/D will rise rapidly with the approximate force required to support the H/D and part(s).
- If system air pressure is lost, lower the H/D immediately. The operator must stay out of the vertical path of the H/D and part(s). The vacuum may lose the force required to hold the part(s) resulting in falling load.

#### CAUTION

- The up/down levers operate similar to a car accelerator, the greater the pressure the higher the speed. Use a speed that will assure controlled movement of the H/D.
- Persons and body parts must never be in the path of the H/D.
- Proper use of the H/D prevents twisting of the wire rope and airlines. Never turn continuously in one direction; rather reverse direction with each cycle.
- The empty H/D should not be left suspended when unattended. Place the H/D on a docking station, or pallet and out of the work paths.

The operator moves the H/D to the pick up point and positions it to pick up the parts.

Depress the down lever or push the H/D down to lower the H/D to pick up the part(s). The vacuum cups should be centered on the part(s).

The operator then actuates the vacuum "on" button and waits until sufficient vacuum is obtained.

The H/D is equipped with the ZA control package and Interlock circuit. It should be tested at the first operation of the day. Depress the up lever to raise the part(s) approximately one inch (30 mm) above the pick up point. The optional Interlock indicator will be green. Then depress the vacuum "off" button. The vacuum off will not function. If the part drops, notify maintenance personnel immediately.

Depress the up lever or lift the H/D to clear the pick up point, and transfer to the set down point.

Position the part(s) over the set down point, depress the down lever or push the H/D down to lower the part(s) until the part(s) contacts the set down point or the Interlock indicator is clear. Depress and hold the vacuum "off" button until the part is released.

Once the part(s) has been released, depress the up lever or lift the H/D as necessary to clear the set down point and part(s). Release vacuum "off" button and transfer H/D to pick up point.

### Controls Installation

#### NOTICE

- Safe installation and operation of Ingersoll-Rand equipment depends on you. Read all instructions before starting work on the system.
- The suspended H/D and part(s) may be raised and lowered simply by exerting force in the desired direction.
- Operators must be trained in the proper use and operation of the H/D

Refer to the **Ingersoll-Rand** Balancer Service Manual Form MHD56151 for detailed instructions.

Purge the air supply for a minimum of 30 seconds prior to the connection of the control package to remove any debris from airlines. This will help prevent damage to controls at start up.

Install the balancer on the support system. Install the control package to the **Ingersoll-Rand** Balancer.

### Vacuum Interlock Adjustments

#### NOTICE

- It may be necessary to depress the vacuum "on", vacuum "off" buttons several times to obtain the correct interlock setting.
- The interlock should not be adjusted until the ZA control adjustments have been completed.

1. Suspend the empty H/D from the balancer at mid travel.
2. Adjust the interlock adjustment screw counterclockwise until approximately 1-1/2 inch (38 mm) of thread is visible.
3. Adjust the interlock adjustment screw clockwise and depress vacuum "off" button repeatedly until the vacuum turns off.
4. Depress the vacuum "on/off" buttons several times to ensure smooth consistent operation of the vacuum circuit. Ensure the interlock valve is shifting completely.

### Interlock Test

1. Depress the vacuum button to turn on the vacuum.
2. Raise the H/D to its maximum up position.
3. Increase the pressure in the balancer by depressing the up lever, 3 or 4 seconds.
4. Depress the vacuum "off" button. The vacuum should remain constant.

5. If the vacuum turns off repeat steps 1 through 4 of the Interlock Adjustments and repeat Interlock Test.
6. Depress the down lever and the vacuum “off” button simultaneously when the H/D begins to lower the vacuum should shut off.

nut on the interlock adjustment screw to prevent the setting from changing.



**CAUTION**

- Repeat the Interlock Test to ensure the setting did not change when the jam nut was tightened.

Once the interlock valve is adjusted correctly, hold the interlock adjustment stem with a suitable pair of pliers and tighten the jam

**SYSTEM TROUBLESHOOTING**

This troubleshooting chart will cover only H/D specific problems. Problems relating to the balancer, controls, or support system will be covered in the applicable manual.

	<b>Probable Cause</b>	<b>Probable Solution</b>
Vacuum does not function consistently or not function at all	Debris in air lines or fittings.	Remove debris.
		Flush air lines.
	Loose or broken air lines or fittings.	Tighten connections or replace air lines or fittings.
	Improper interlock adjustment.	Refer to Adjustment Procedures.
	Faulty vacuum button.	Replace vacuum button.
	Faulty vacuum valve.	Replace vacuum valve.
	Faulty vacuum cup.	Replace vacuum cup.
Interlock does not prevent vacuum from shutting off.	Debris in air lines or fittings.	Remove debris.
		Flush air lines.
	Loose or broken air lines or fittings.	Tighten connections or replace airlines or fittings.
	Improper interlock adjustment.	Refer to Adjustment Procedures.
	Faulty Interlock valve.	Replace Interlock valve.
Part(s) shift or slip with vacuum engaged	Deteriorated, loose or torn vacuum cup(s).	Tighten or replace vacuum cup(s).
	Insufficient air supply pressure	Adjust air supply to the highest maintainable pressure.

## PREVENTATIVE MAINTENANCE

The purpose of the preventative maintenance recommendations is to prevent unexpected breakdowns and unnecessary wear by periodically inspecting, cleaning, and testing the balancer, support system, and H/D. Inspection intervals should be based on the type of environment and frequency of usage. Operating the system in a dirty environment or frequent usage will require a shorter interval between inspections and maintenance.

A Preventative Maintenance Program should be developed based on the following information and use of the H/D.

### Air Supply

A clean, dry, oil and rust free air supply is the most important factor in proper system operation, and serviceability. In-line **air oilers / lubricators** should **never** be installed on the balancer's air supply. Oil will damage the controls, causing erratic and sluggish operation of the system. An airline regulator and five (5) micron filter are recommended to improve the quality of air to the balancer and H/D. The balancer is designed to attain maximum capacity at 100 psi (6.9 bar). If the system pressure is above 100 psi (6.9 bar), damage to the controls or balancer may occur.

### Wire Rope and Hook

#### **NOTICE**

• **Load hook or wire rope should be replaced with Ingersoll-Rand replacement parts only.**

Inspect wire rope daily for wear by the operator. Wire rope that is bulging, frayed, or worn excessively should be reported to your maintenance personnel for replacement.

Inspect hooks for wear and ease of rotation. Ensure that the hook gate closes completely and locks. Hooks that do not lock must be replaced.

### Controls, Hose, Tube and Pipe

Inspect all hose, tube, and pipe for leakage, kinks, and proper connection. Tighten all connections or replace damaged air lines or fittings. This will keep equipment from drifting or sluggish operation.

Inspect the H/D control handles for leaks at tube connections, valves, pushbuttons, and levers. Inspect handles for cracks, missing hardware and deteriorated grips. Repair or replace as necessary.

Inspect the control manifold/regulator for leakage at adjustment screws, and the valve body. Ensure the manifold/regulator is properly connected to the balancer end cap. Repair or replace as necessary, refer to the **Ingersoll-Rand** Balancer Service Manual Form MHD56151.

### Handling Device (H/D)

1. Inspect all welds for cracks.
2. Inspect all fasteners for security.
3. Inspect all bearings and rotating parts for smooth operation and proper lubrication.
4. Check all valves for leakage.
5. Inspect the vacuum circuit for proper operation and sufficient vacuum indication.
6. Inspect the interlock circuit for leakage and test for proper operation.

### Support System

Refer to applicable manual for proper inspection and preventative maintenance procedures.

### General Maintenance

#### **WARNING**

- **The interlock valve must be adjusted and tested prior to putting the H/D into production.**
- **Prior to any maintenance being performed the system air supply should be shut off and locked out.**
- **The load cable of the balancer should be slack.**

#### **NOTICE**

- **Use Ingersoll-Rand replacement parts only.**

Labeling all air lines with valve and port number or location prior to disconnection will ease reassembly of H/D.

1. Lower H/D to the floor or a suitable work surface.
2. Turn off and lock out the system air supply.
3. Depress the down lever until all air has exhausted from the balancer and the wire rope is slack.
4. Remove the H/D from the hook.
5. Label and disconnect the air lines at the top of the H/D.
6. Ensure all cable ties are removed prior to any component removal and replaced upon completion of tasks.

# CARTON H/D PNEUMATIC SCHEMATIC DRAWING

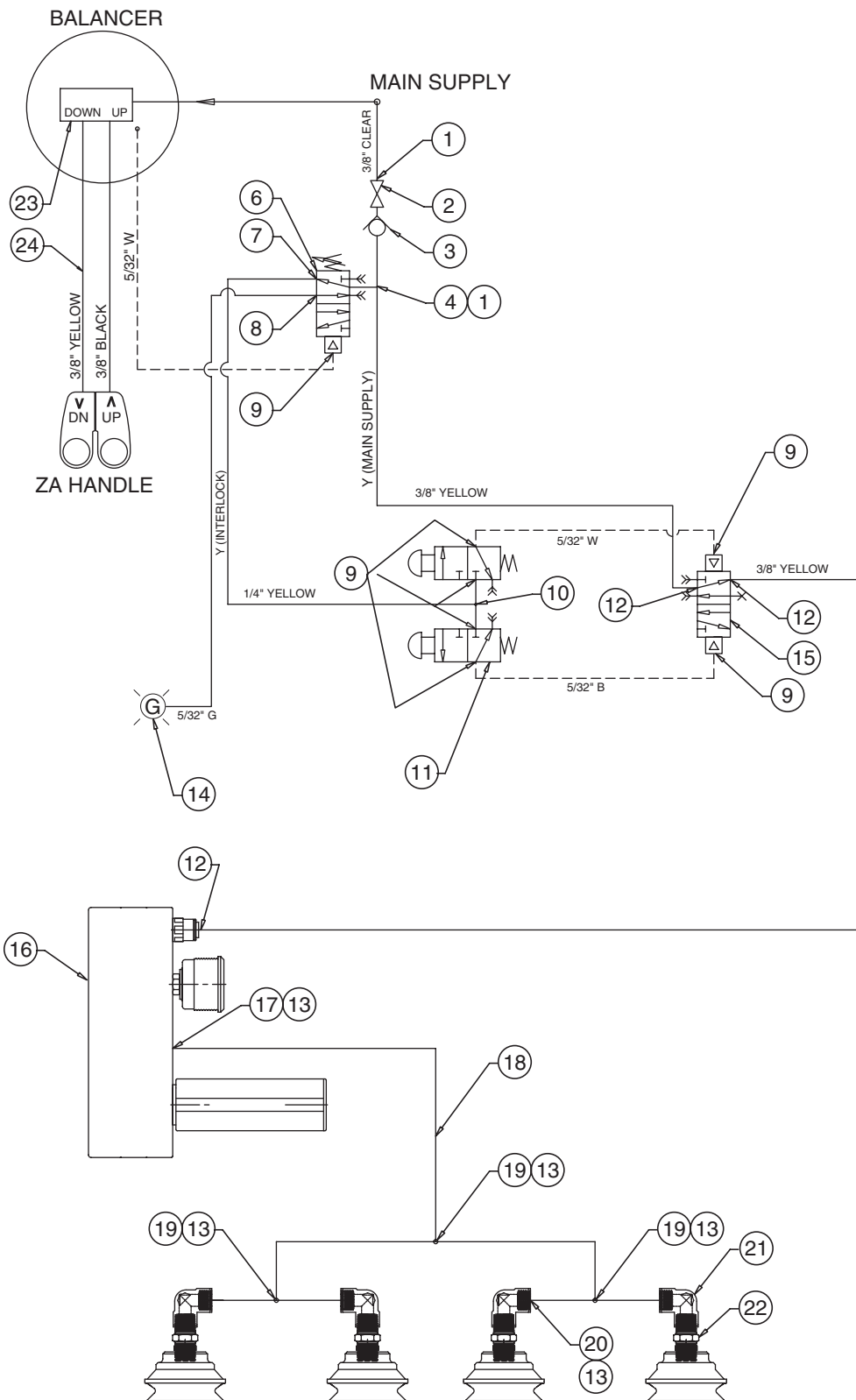

(Dwg. MHP2633)



## CARTON H/D PNEUMATIC SCHEMATIC PARTS LIST

Item No.	Description of Part	Total Qty.	Part Number
1	Tube	2	93977
2	Shut Off Valve	1	90362
3	Check Valve	1	13270
4	Fitting, Tee	1	10718
6	Interlock Valve	1	99064
7	Fitting, Elbow	1	93972
8	Fitting, Elbow	1	93970
9	Fitting, Elbow	7	93969
10	“Y” Push on Fitting	1	99159
11	Poppet Valve	2	93849
12	Fitting, Elbow	2	93978
13	PIAB Hose Clamp	14	16012262
14	Indicator Light - Green	1	93861
15	Pilot Valve	1	16012197
16	PIAB Vacuum Pump	1	97306379
17	PIAB Fitting	1	16012205
18	PIAB Hose	1	16012213
19	PIAB “T” Fitting	3	16012221
20	PIAB Fitting	4	16012239
21	MCMaster - CARR Fitting	4	16012239
22	MCMaster - CARR Fitting	4	16012254
23	ZA Manifold Assembly	1	15071
24	Quad-Coil Hose Assembly with Fittings	1	10813

# CARTON H/D ASSEMBLY DRAWING

5 inch x 7 inch Vacuum Cup Configuration

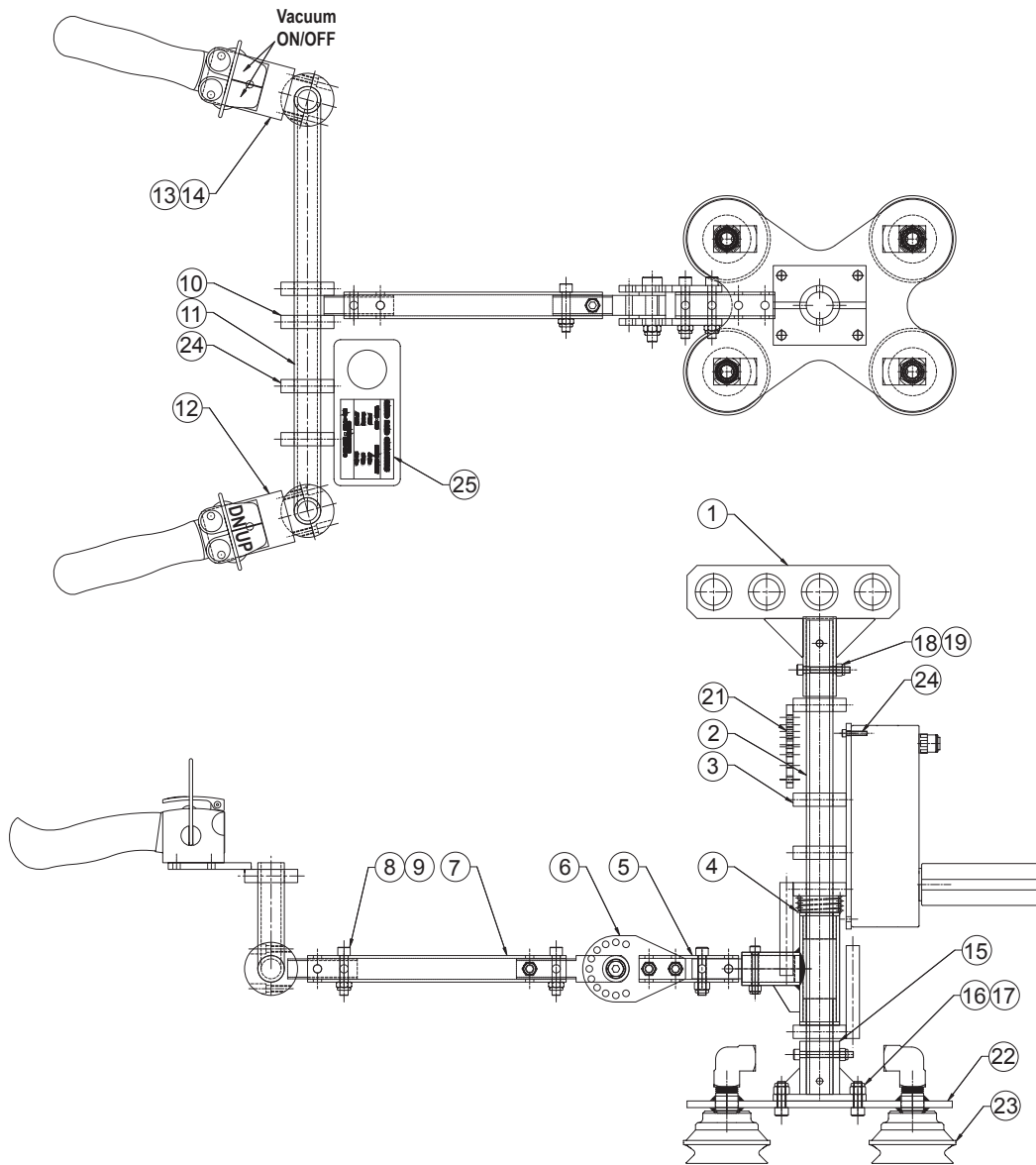

(Dwg. MHP2632)

## CARTON H/D PARTS LIST

Item No.	Description of Part	Total Qty.	Part Number
1	4 Position Manual C.G. ~ W/C	1	87306395
2	Bail	1	87306346
3	Vacuum Pump Mounting Bracket	1	87306361
4	Swiveling Handle Assembly for Bail	1	16010662
5	Telespar Tube	1	54030507
6	Handle Pivot Sub-Assembly	1	54030499
7	Tel-Spar Tubing	1	87306387
8	Screw (5/16-18 x 1.50" LG. SHCS)	2	70936
9	Locknut (5/16-18)	2	75504
10	Handle Adapter	1	54030523
11	Bent Handle	1	99169
12	ERGO ZA Control Mounted Assembly	1	54028014
13	ERGO ZA Handle Bracket	1	99168
14	3 Port ZA Control Handle	1	18621
15	Pivot Attachment Plate	1	54025507
16	Screw (M8-1.25 x 25 mm. SHCS)	4	87306429
17	Locknut (M8-1.25)	4	87306437
18	Screw (M6-1.0 x 45 mm. SHCS)	4	87306403
19	Locknut (M6-1.0)	4	87306411
21	Mounting Bracket	1	16009854
22	Custom Template for Vacuum Cup Configuration	1	87306353
23	PIAB Vacuum Cup (Nitrile)	4	87306452
24	Vacuum Gauge Mounting Bracket	1	16012312
25	Capacity Label	1	16012320

# CARTON H/D ASSEMBLY DRAWING

10 inch x 14 inch Vacuum Cup Configuration

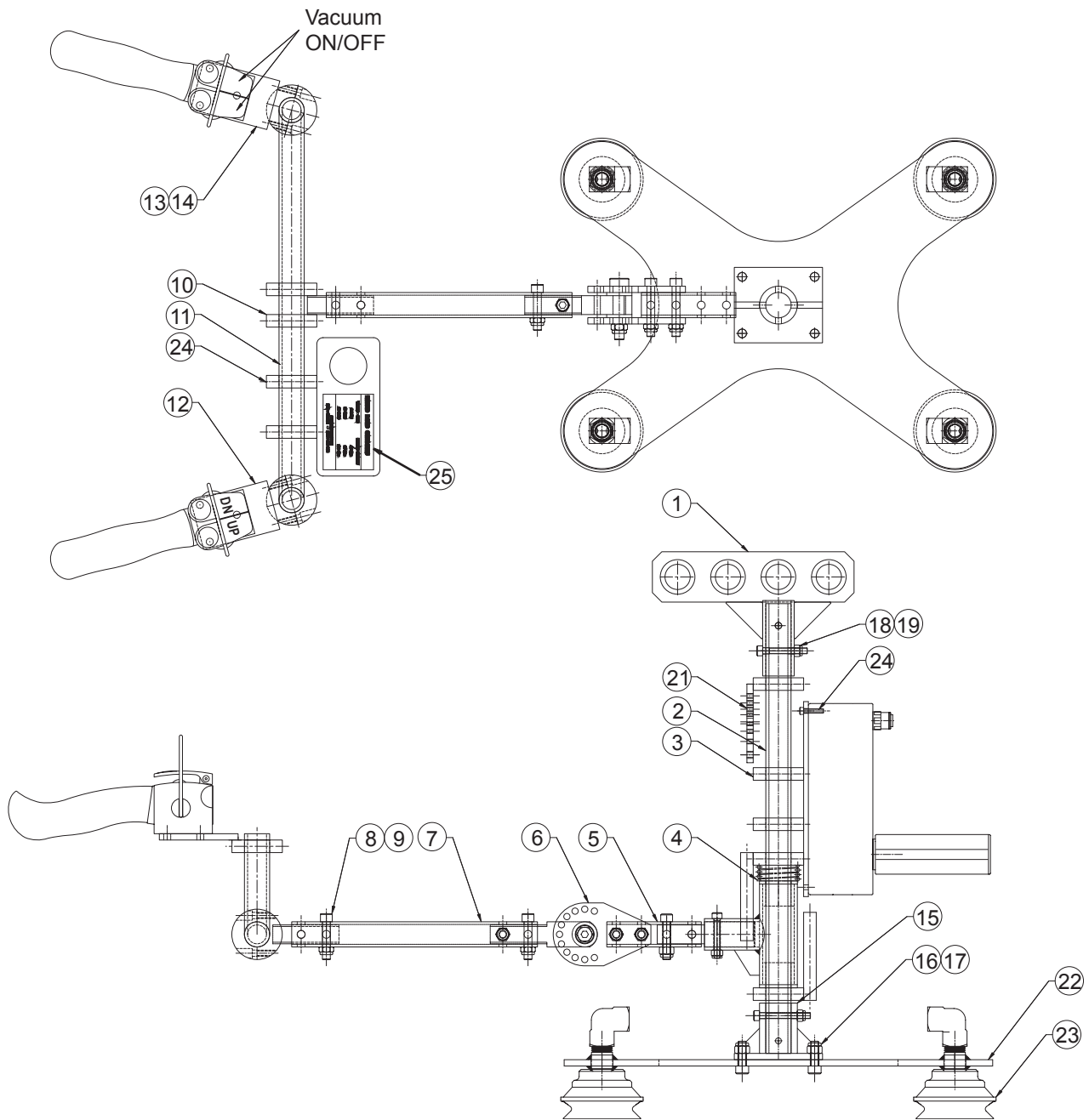

(Dwg. MHP2634)

## CARTON H/D PARTS LIST

Item No.	Description of Part	Total Qty.	Part Number
1	4 Position Manual C.G. ~ W/C	1	87306395
2	Bail	1	87306346
3	Vacuum Pump Mounting Bracket	1	87306361
4	Swiveling Handle Assembly for Bail	1	16010662
5	Telespar Tube	1	54030507
6	Handle Pivot Sub-Assembly	1	54030499
7	Tel-Spar Tubing	1	87306387
8	Screw (5/16-18 x 1.50" LG. SHCS)	2	70936
9	Locknut (5/16-18)	2	75504
10	Handle Adapter	1	54030523
11	Bent Handle	1	99169
12	ERGO ZA Control Mounted Assembly	1	54028014
13	ERGO ZA Handle Bracket	1	99168
14	3 Port ZA Control Handle	1	18621
15	Pivot Attachment Plate	1	54025507
16	Screw (M8-1.25 x 25 mm. SHCS)	4	87306429
17	Locknut (M8-1.25)	4	87306437
18	Screw (M6-1.0 x 45 mm. SHCS)	4	87306403
19	Locknut (M6-1.25)	4	87306411
21	Mounting Bracket	1	16009854
22	Custom Template for Vacuum Cup Configuration	1	87306478
23	PIAB Vacuum Cup (Nitrile)	4	87306452
24	Vacuum Gauge Mounting Bracket	1	16012312
25	Capacity Label	1	16012320

## PARTS ORDERING INFORMATION

Handling Systems are designed and constructed to provide long, trouble-free service. In time it may become necessary to order and install new parts to replace those that have been subjected to wear.

The use of other than **Ingersoll-Rand** replacement parts may result in decreased performance, and may invalidate the warranty. For prompt service and genuine **Ingersoll-Rand** parts, provide your nearest Distributor with the following:

1. Complete model number and serial number as it appears on the nameplate.
2. Part number and part description as shown in this manual.
3. Quantity required.

For your convenience and future reference it is recommended that the following information be recorded.

**Model Number** \_\_\_\_\_

**Serial Number** \_\_\_\_\_

**Date Purchased** \_\_\_\_\_

### Return Goods Policy

If it becomes necessary to return the complete Handling System or certain parts to the factory, contact the Distributor from whom you purchased the Handling System, or the nearest **Ingersoll-Rand** Distributor in your locality, **Ingersoll-Rand** will not accept any returned goods for warranty or service work unless prior arrangements have been made and written authorization has been provided from the location where the goods were purchased.

### NOTICE

• **Continuing improvement and advancement of design may cause changes to this Handling System which are not included in this manual. Manuals are periodically revised to incorporate changes. Always check the manual edition number on the front cover for the latest issue.**

### Disposal

When the life of the Handling System has expired, it is recommended that the Handling System be disassembled, degreased and parts separated as to materials so that they may be recycled.

## SERVICE AND MAINTENANCE

For additional information contact:

**Ingersoll-Rand**  
 U.S. and International Sales  
 1872 Enterprise Drive  
 Rochester Hills, MI 48309  
 Phone: (248) 293-5700  
 Fax: (248) 293-5800

For additional information on related products order publication by the referenced Part/Document Number listed:

Product	Part/Document Number
Balancer Service Manual	MHD56151

## WARRANTY

The Company warrants that the Equipment manufactured by it and delivered hereunder will be free of defects in material and workmanship for a period of twelve months from the date of placing the Equipment in operation or eighteen months from the date of shipment, whichever shall first occur. Separately sold parts are warranted for a period of six months from date of shipment. The Purchaser shall be obligated to promptly report any failure to conform to this warranty, in writing to the Company within said period, whereupon the Company shall, at its option, correct such nonconformity, by suitable repair to such Equipment or, furnish a replacement part F.O.B. point of shipment, provided the Purchaser has stored, installed, maintained and operated such Equipment in accordance with good industry practices and has complied with specific recommendations of the Company. Accessories or equipment furnished by the Company, but manufactured by others, shall carry whatever warranty the manufacturers have conveyed to the Company and which can be passed on to the Purchaser. The Company shall not be liable for any repairs, replacements, or adjustments to the Equipment or any costs of labor performed by the Purchaser or others without the Company's prior written approval.

The effects of corrosion, erosion and normal wear and tear are specifically excluded. Performance warranties are limited to those specially stated within the Company's proposal.

**The company makes no other warranty or representation of any kind whatsoever, expressed or implied, except that of title, and all implied warranties of merchantability and fitness for a particular purpose, are hereby disclaimed.**

Correction by the Company of nonconformities whether patent or latent, in the manner and for the period of time provided above, shall constitute fulfillment of all liabilities of the Company for such nonconformities, whether based on contract, warranty, negligence, indemnity, strict liability or otherwise with respect to or arising out of such Equipment.

The Purchaser shall not operate Equipment which is considered to be defective, without first notifying the Company in writing of its intention to do so. Any such use of Equipment will be at the Purchaser's sole risk and liability.

## Limitation of Liability

The remedies of the purchaser set forth herein are exclusive, and the total liability of the company with respect to this contract or the equipment and services furnished hereunder, in connection with the performance or breach thereof, or from the manufacture, sale, delivery, installation, repair or technical direction covered by or furnished under this contract, whether based on contract, warranty, negligence, indemnity, strict liability or otherwise, shall not exceed the purchase price of the unit of equipment upon which such liability is based.

The company and its suppliers shall in no event be liable to the purchaser, any successors in interest or any beneficiary or assignee of this contract for any consequential, incidental, indirect, special or punitive damages arising out of this contract or any breach thereof, or any defect in, or failure of, or malfunction of the equipment hereunder, whether based upon loss of use, lost profits or revenue, interest, lost goodwill, work stoppage, impairment, of other goods, loss by reason of shutdown or non-operation, increased expenses of operation, cost of purchase of replacement power or claims of purchaser or customers of purchaser for service interruption whether or not such loss or damage is based on contract, warranty, negligence, indemnity, strict liability or otherwise.



[www.irco.com](http://www.irco.com)